

Presence detector standard attachment

Order no.: 0316 02 / 0316 04

Presence detector basics

Like a movement detector or an alarm system detector, the presence detector standard attachment, too, belongs to the family of PIR detectors.

At first glance, all three types are equivalent. Due to their different internal design and different signal detection and treatment procedures, these types are suitable for different applications:

- Depending on brightness, a movement detector switches the light on when movement is detected. It switches the light off independent of brightness when no movement is detected anymore, at the latest, however, after 90 minutes (forced shutoff).
- An alarm system detector reports detected movements independent of brightness to an alarm center. The number of pulses generated within a fixed time span is often adjustable.

- A presence detector is designed to switch on the light depending on brightness when presence is detected and then to switch it off again when it is no longer needed, i.e. when it is already too bright or when there is no one in the room anymore.

What the detector does therefore is to detect the presence of persons depending on a preset brightness.

The differences between these PIR detectors lie essentially in the design of the Fresnel lens, the adaptation to ambient conditions, the type of fitting and the type of movement or brightness signal transmitted.

Function

The presence detector standard attachment is therefore used to monitor internal rooms for the presence of persons.

It is installed exclusively under the ceiling of the room from where it monitors the working surface below (figure **A**).

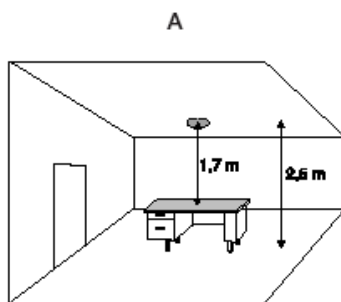

The detector works with a passive infrared sensor (PIR sensor) and responds to thermal movement triggered by persons, animals or objects. When movements are detected below a presettable brightness threshold, the detector switches on an electrical consumer. The device remains on as long as movements are detected.

When no movements are detected anymore, the device switches off after a preset shut-off delay.

If the brightness on the surface under supervision is permanently at least twice as high as the preset brightness (e.g. due to supplementary daylight), the test LED flashes and the presence detector switches off after 10 minutes at the latest even if movements are still being detected.

The presence detector standard attachment is designed for switching purposes only and is used in combination with a System 2000 insert (for 60 mm flushmounting boxes).

It can be combined with all System 2000 inserts. Dimmer inserts can be used as switching inserts. The insert must be selected depending on load to be connected.

The device can be used together with an extension unit insert for presence detectors. In this case, the detection and treatment of signals is independent of brightness (see chapter "Use of extension units").

Important:

The load rating specifications are set out in the operating instructions of the individual flush-mounting inserts.

**Safety instructions**

Attention: Electrical equipment must be installed and fitted by qualified electricians only.

The device is **not suitable for safety disconnection**.

Depending on the type of flush-mounting insert used, the deactivation of the device does not isolate the load electrically from the power mains. When working on the load or on the device, the device must be safely disconnected from the power mains.

Non-observation of the installation instructions may cause fire or other hazards.

Installation

The presence detector standard attachment is installed exclusively under the ceiling.

Select a flush-mounting insert in accordance with the load to be used, install in the ceiling and connect to the power supply and/or load (see connection diagrams).

Plug the presence detector standard attachment into the insert without exerting pressure on the lens. The electrical contact is established through the connector pins.

Sources of interference:

Do not install in the direct vicinity of heat sources such as lamps (figure B).

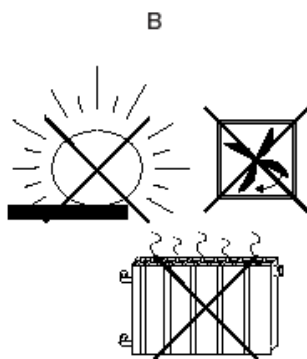

The cooling lamp may be interpreted by the PIR sensors as a thermal change and lead to repeated switching.

If necessary, restrict the detection field with the supplied snap-on mask (see chapter "Snap-on mask"). Do not install close to fans, radiators or ventilation ducts. Moving air (e.g. draught through open windows) might be detected and lead to repeated switching.

Select the best suited place for the installation.

The field of detection should not be restricted by furniture, columns, etc.

Avoid direct sunlight into the sensor window.

The sensors can be irreparably damaged by the high thermal energy.

The brightness sensor should be installed away from windows to avoid the undesirable influence of scattered light.

Install the presence detector standard attachment free from vibrations to avoid switching triggered by sensor movements.

Adjustments (figure C)

To adjust the brightness or the shut-off delay, withdraw the trimming ring from the presence detector standard attachment.

The controls are then accessible.

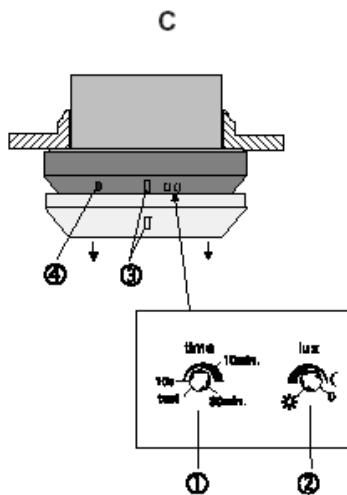

① Shut-off delay: 1 second (test operation).

The **time** potentiometer permits adjusting the time intervals in fine steps between ca. 10 seconds and 30 minutes.

② Brightness: adjustable between 10 lux (moon symbol) and 1000 lux (sun symbol) and manual setting "0".

Important: In the "0" setting, the presence detector standard attachment can only be switched on from an extension unit.

The shut-off brightness in this case is approximately 400 lux. This setting permits to deactivate the automatic detection mode.

Typical application:

Orientation lighting in residential rooms.

Snap trimming ring back onto the detector after the adjustment. The nose of the brightness sensor must engage in the corresponding notch in trimming ring ③.

The test LED ④ is useful for diagnosis and adjustment (see chapter "Test LED functions") and is visible only after removal of the trimming ring.

Installation and test mode

- Install the insert.
- Connect the lamps (e.g. workplace illumination) and the power supply.
- Snap the presence detector onto the insert.
- Set the **time** potentiometer to the shortest interval (test 1 sec.) (see figure D).
- Set the **lux potentiometer** to daytime operation (sun symbol) (see figure D).
- Switch on the power supply.

The lamps connected are switched on by the presence detector for a measuring cycle of abt. 1 minute. During the measuring cycle no operation is possible. After this time, the device switches off and is then in the test mode.

Each movement now detected switches on the device for at least 1 second (with retriggering function).

A walking test to check the field of detection can now be performed. If necessary, the snap-on mask must be used (see chapter "Snap-on mask").

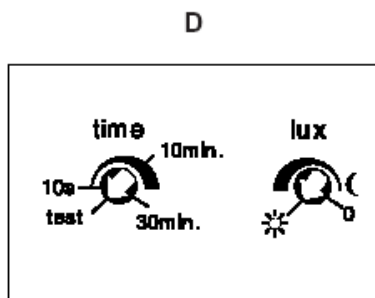

Snap-on mask

i The device is delivered with the transparent snap-on mask for protection of the lens system.
Remove the mask to obtain the maximum field of detection.

The snap-on mask supplied with the detector can be used to blank out undesired zones or sources of interference (see chapter "Installation - sources of interference") by restricting the detection range of the device.

The mask is snap-fitted on the lens system (figure E).

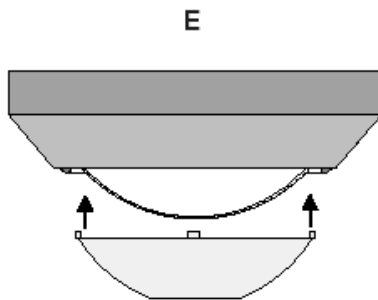

The removed mask is cut out with scissors along the marked lines (figure F).

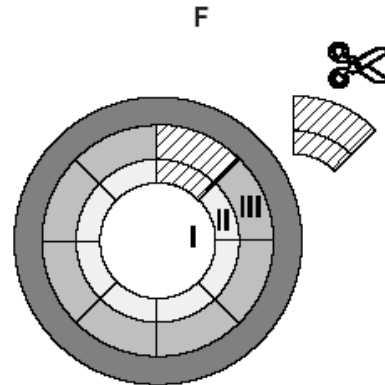

Cutting out the mask changes the diameter of the detection field on the floor as follows:

Sectors I through III see figure F.

| | |
|---------------------------------------|------------------|
| Full mask without cut-outs, sector I: | Ø approx. 2.20 m |
| Sector II cut out: | Ø approx. 4.00 m |
| Sectors II and III cut out: | Ø approx. 6.00 m |
| Without mask: | Ø approx. 8.00 m |

The figures are based on a fitting height of approx. 2.50 m.

Adaptation of sensor to the lighting conditions of the monitored surface

To prevent the presence detector from being switched out again by the lamp it has just activated (brightness exceeded), the detector must be adjusted to the actual lighting conditions.

The adjustment must therefore be made under those lighting conditions that are required for minimum brightness at the place of work, i.e. lamps switched on with as little scattered light as possible.

Procedure:

- Set the **time** potentiometer to maximum interval (30 minutes) (figure G).
- Set the **lux** potentiometer to daytime operation (sun) (figure G), the LED must be off.
- Activate the device by making a movement inside the field of detection.

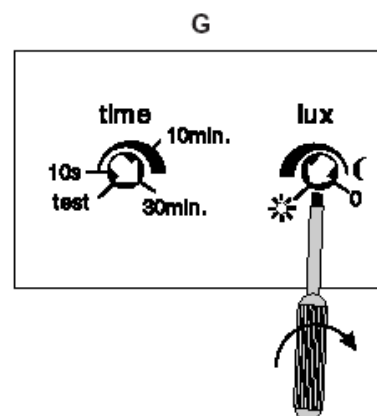

Some lamps such as fluorescent lamps, for instance, need a certain time to reach full brightness.

Therefore:

- Observe the starting time of the lamps.



Important:

Avoid scattered light (e.g. from additional daylight or from nearby lamps).

- Then, turn the **lux** potentiometer in the direction of the moon symbol (figure G) until the test LED ④ (figure H) lights up.

Important: Do not shade the light sensor ⑤ (figure H) during this adjustment. The sensor must be able to measure the light reflected from the full monitored surface.

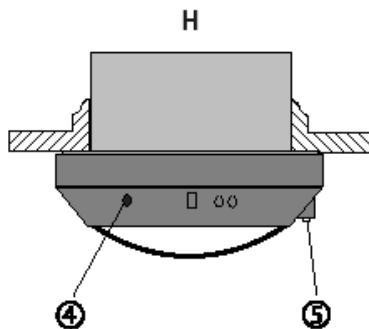

The presence detector standard attachment is then adjusted to the actual brightness prevailing at the monitored surface.

- Set the **time** potentiometer to the desired shut-off delay.
- Leave the field of detection and wait until the presence detector switches off after the time interval just set.

Important:

If the first setting is not fully satisfactory, please observe the instructions in the chapters: “Standard setting”, “Test LED function” and “Setting guidelines”.

Standard setting

If it is not possible to simulate the desired lighting conditions with the means available (room has no darkening facility), a standard setting can be selected. For this setting, the **lux** potentiometer must be adjusted as shown in figure I.

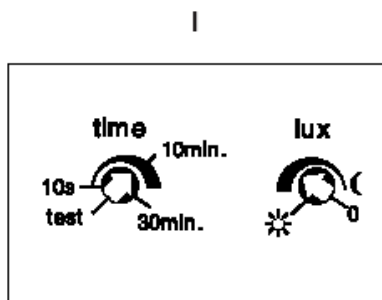

Any readjustments can be made with the help of the test LED and the setting guidelines.

There is no response to movements inside the field of detection when the preset brightness (load switched off) is exceeded by additional light such as daylight or light from nearby lamps.

In this case, the test LED is lit up or flashes and the lighting remains off.

Functions of the test LED

When the first attempt to adjust the brightness was not satisfactory, the setting can be verified and the brightness be readjusted with the help of the test LED and the setting guidelines.

**States of the test LED and their meaning
(load disconnected):**LED OFF

- monitored surface too dark:
load switched on after detection of movements.

LED ON or LED flashing

- monitored surface bright enough:
load remains off even after detection of movements.

**States of the test LED and their meaning
(load connected):**LED OFF

- monitored surface too dark:
The load remains on after detection of movement and the retriggering function is active. If no movement is detected, the device switches off after the preset shut-off delay.

LED ON

- monitored surface sufficiently illuminated by the activated lights:
The load remains on after detection of movement and the retriggering function is active. If no movement is detected, the device switches off after the preset shut-off delay.

LED flashing

- monitored surface very bright due to the light from burning lamps and external light:
The load is switched off after 10 minutes at the latest with or without detection of movements, since the brightness at the working surface even without lighting is higher than the preset brightness.

Important:

In the first seconds after shutoff, this brightness may seem to be insufficient.

Setting guidelines**Load remains on even at high levels of external light**

Cause:
Preset brightness value too high.

Remedy:
Turn **lux** potentiometer towards moon symbol.

Load is not activated despite insufficient brightness and movement detection

Cause 1:
Preset brightness value too low.

Remedy:
Turn **lux** potentiometer towards sun symbol.

Cause 2:
Device deactivated from extension unit (e.g. pushbutton).

Remedy:
Re-activate from extension unit.

Cause 3:
Device set to "0" (chapter "Settings").

Remedy:
Re-activate from extension unit.

Load switches off in spite of the presence of persons and insufficient lighting levels

Cause:
Preset shut-off delay too short.

Remedy:
Prolong delay with **time** potentiometer.

Cause:
Detection problem: surface to be monitored not completely in the detector's field of view. View obstructed by furniture or columns.

Remedy:
If needed, use another presence detector extension unit to enlarge the field of detection (see chapter "Use of extension units").

Load switched on without any noticeable movement detectedCause:

Sources of disturbance in the field of detection.

Remedy:

see chapter "Installation".

Tip:

With fewer movements expected in the monitored area, the shut-off delay should be selected longer to prevent premature switching off of the lights.

A shut-off delay of 10 minutes is recommended as a standard value (see figure I).

Load switches off briefly and then on againCause:

After shut-off, the ambient brightness falls below the preset minimum brightness level so that the device switches on again immediately when movement is detected.

Remedy:

Increase the shut-off threshold by turning the **lux** potentiometer a little bit towards the sun symbol.

Use of extension units

The presence detector standard attachment on a System 2000 extension unit insert for presence detectors enlarges the detection field of the main unit.

Important:

- **The extension unit is not suitable for direct switching of loads and merely transmits movement detection signals independent of brightness to the main unit.**
- **The presence detector standard attachment cannot be used on an extension unit insert designed for two-wire operation.**

If the main unit and the extension unit are each equipped with a presence detector standard attachment, switching is performed dependent on the brightness value detected by the main unit.

When used in this configuration, the setting controls of the attachment on the extension unit are not operational. The adjustment is performed only at the main unit.

When the presence detector standard attachment is used in combination with the extension unit insert for presence detectors, the detection system is locked for about 3 seconds after the lights have been shut off before they can be switched on again from the extension unit.

Activation through extension input 1 of the insert:

If a flush-mounting insert with extension input 1 (e.g. relay insert) is used under the main presence detector and switched off through extension input 1, the reactivation, within the next 2 minutes is then only possible through extension input 1.

Movements detected by the PIR sensors during this interval will not reactivate the device. If movements are detected within this 2-minute interval, the main unit will be locked again for another 2 minutes.

The automatic mode of the main unit will be reactivated only if the 2-minute interval has elapsed without movements being detected. In this case, all movements detected will again lead to switching on of the lamps depending on prevailing brightness conditions.

This feature offers the possibility of deactivating the automatic mode on purpose if, for instance, a room is to be darkened.

The lighting can be switched on via extension input 1 independent of brightness.

The brightness evaluation remains active. This means that the lighting is switched off after 10 minutes if it is not needed.

Field of detection

The presence detector standard attachment has a 360° field of detection.

The PIR sensor array is composed of 6 levels of detection and 80 lenses.

The field of detection measures approx. 5 m in diameter at desktop level (approx. 80 cm). On the floor, the diameter of the detection field measures approx. 8 m.

These ranges are referred to an installation under the ceiling and a fitting height of 2.5 m and tangential, i.e. lateral direction of movement.

View from above: figure J

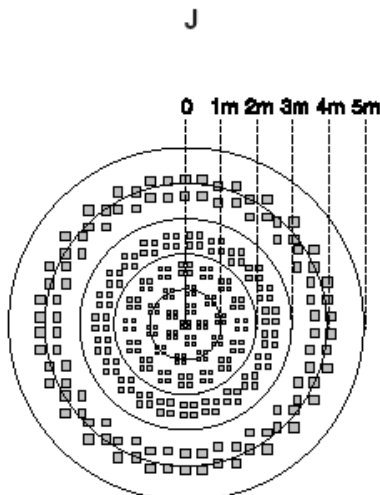

Sideview: figure K

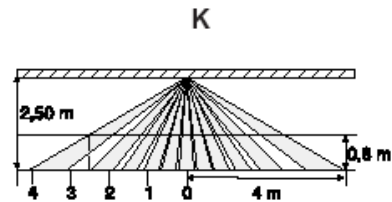

Important:

Range reductions must be expected if movement is directed towards the presence detector. In such a case, a detection in the outer 4 m range is not granted.

If a person moves too fast towards the presence detector, there may be the impression of reduced detection range.

Observe also the possible on-delays of the lamps used.

These facts are especially important when the device is used as ceiling detector.

If the installation heights are increased the detector's sensitivity to movements is lower.

Technical data

| | |
|--|-----------------|
| Angle of detection: | 360° |
| Nominal field of detection at desktop level: | Ø approx. 5 m |
| Nominal field of detection at floor level: | Ø approx. 8 m |
| Height of installation for nominal field of detection: | approx. 2,5 m |
| The nominal field of detection varies with the height of installation. | |
| Number of lenses /levels of detection: | 80 / 6 |
| Nominal voltage: | 230 V AC; 50 Hz |

| | |
|--|---|
| Switching capacity: | see insert instructions |
| Shut-off delay: | 1 sec. in test mode, approx. 10 sec. - 30 min. |
| Brightness: | approx. 10 - 1000 lux |
| Number of extensions connected to flush-mounting insert: | passive |
| (e.g. pushbuttons): | unlimited |
| active: | see instructions for extension unit insert for presence detectors |
| Length of extension unit connection cable: | 100 m max. |

Application of inserts

The presence detector standard attachment can be used exclusively for switching applications. The detector is used in combination with the inserts of the system 2000 series. Dimmerinserts can be used as switching inserts:

- Universal dimmer insert
Art.-Nr. 0305 00 (figure **L**)
- LV dimmer insert
Art.-Nr. 0331 00 (figure **L**)
- relay insert
Art.-Nr. 0853 00 (figure **M**)
- Tronic switching insert
Art.-Nr. 0866 00 (figure **N**)
- HLK relay insert
Art.-Nr. 0303 00 (figure **O**)
- 1-10 V control unit
Art.-Nr. 0860 00 (figure **P**)
- extension unit insert for presence detectors
Art.-Nr. 0335 00 (figure **Q**)

Important: Parallel connection of presence detector main units is not allowed.

The device cannot be used in combination with the 2-wire extension unit insert as active extension unit. The 2-wire extension unit insert can, however, be used in combination with a pushbutton attachment as passive extension unit.

Further installation details are set out in the operating instructions of the insert.

Connection diagrams

Combination of presence detector standard attachment with universal dimmer insert or LV dimmer insert (figure **L**)

The device can be controlled from a secondary unit only through extension input terminal 1.

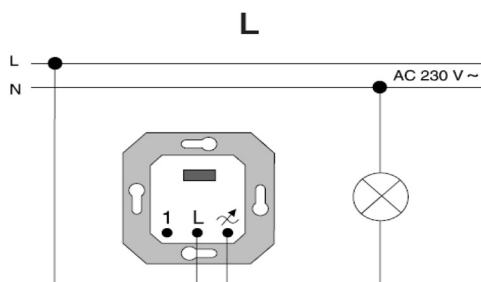

Combination of presence detector standard attachment with relay insert (figure **M**).

Pushbutton T (n.o. contact) can be used to trigger a brightness-independent switching action.

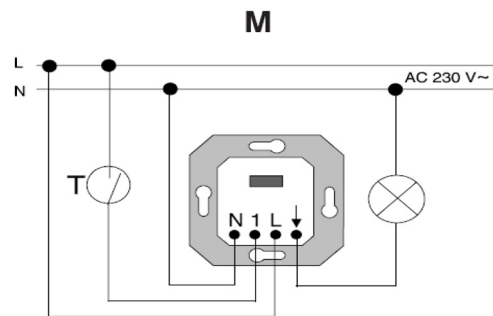

Combination of presence detector standard attachment with Tronic switching insert (figure **N**).

Pushbutton T (n.o. contact) can be used to trigger a brightness-independent switching action.

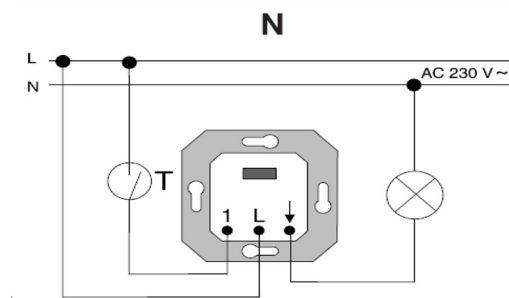

Combination of presence detector standard attachment with a HLK relay insert (fig. **O**).

The device can be controlled from a secondary unit only through extension input terminal 1.

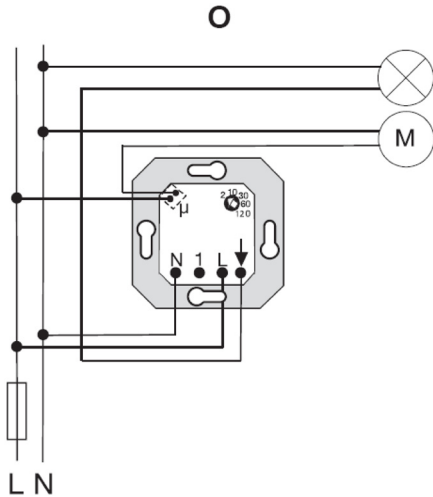

Combination of presence detector standard attachment with a 1-10 V control unit (fig. **P**)

The device can be controlled from a secondary unit only through extension input terminal 1.

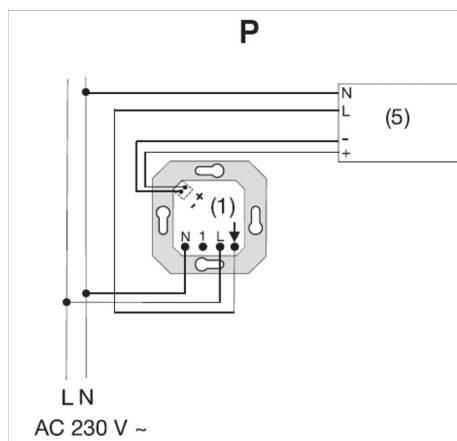

Connection of extension unit insert for presence detectors ① to main unit ② (e.g. Tronic switching insert) (figure **Q**).

Connection of further extension units ③.

Pushbutton T (n.o. contact) can be used to trigger a brightness-independent switching action.

The maximum length of the cable connected to extension input 1 is 100 m.

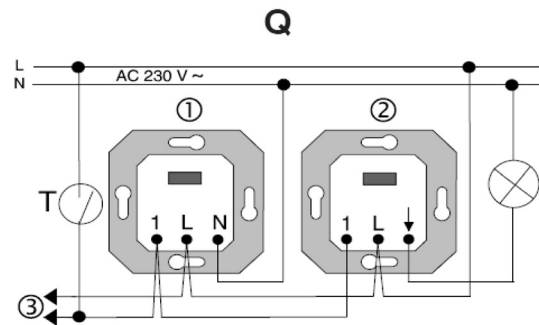

Connection of mechanical pushbutton T (n.o. contact) and/or extension unit insert for 2-wire operation (with pushbutton attachment) ① to main unit ② (e.g. Tronic switching insert) (figure **R**).

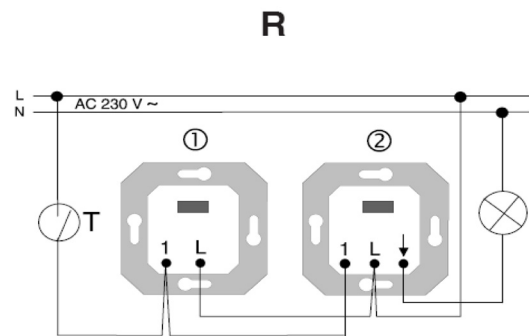

When controlling the presence detector standard attachment through extension input 1 of the insert, please observe the instructions set out in the chapter "Use of extension units".

Acceptance of guarantee

We accept the guarantee in accordance with the corresponding legal provisions.

Please return the unit postage paid to our central service department giving a brief description of the fault:

Gira
Giersiepen GmbH & Co. KG
Service Center
Dahlienstrasse 12
D-42477 Radevormwald

Gira
Giersiepen GmbH & Co. KG
Postfach 1220
D-42461 Radevormwald

Telefon: +49 / 21 95 / 602 - 0
Telefax: +49 / 21 95 / 602 - 339
Internet: www.gira.de