

Issue:  
21.06.2022  
21393100

# Heating actuator 6-gang with controller

## Order no. 2139 00

## Table of Contents

<b>1</b>	<b>Information on the product</b> .....	<b>6</b>
1.1	Product catalogue .....	6
1.2	Function .....	6
1.3	Device components .....	10
1.4	Technical data.....	11
<b>2</b>	<b>Safety instructions</b> .....	<b>12</b>
<b>3</b>	<b>Mounting and electrical connection</b> .....	<b>13</b>
<b>4</b>	<b>Commissioning</b> .....	<b>15</b>
<b>5</b>	<b>Application programs</b> .....	<b>17</b>
<b>6</b>	<b>Scope of functions</b> .....	<b>18</b>
<b>7</b>	<b>Notes on software</b> .....	<b>21</b>
<b>8</b>	<b>Operation and indication</b> .....	<b>22</b>
8.1	Button operation and indication functions .....	22
8.2	ETS configuration .....	28
8.2.1	Manual operation .....	28
8.2.2	Status indication .....	31
8.3	Operation and indication parameters.....	33
8.4	Operation and indication object list.....	36
<b>9</b>	<b>Valve outputs</b> .....	<b>37</b>
9.1	Priorities for valve outputs.....	37
9.2	Channel configuration .....	38
9.2.1	Channel configuration parameters .....	39
9.3	Channel-independent functions .....	39
9.3.1	Heat requirement.....	39
9.3.2	Pump control .....	44
9.3.3	Largest command value .....	50
9.3.4	Summer / winter mode switchover .....	54
9.3.5	Service mode.....	57
9.3.6	Failure of the valve operating voltage.....	61
9.4	Valve output - General.....	63
9.4.1	Name .....	63
9.4.2	Data formats for command values.....	64
9.4.3	PWM cycle time .....	70
9.4.4	Valve direction of action .....	72
9.4.5	Reset behaviour .....	73

9.4.6	"Valve output - General" parameters .....	75
9.4.7	Objects for "Valve output - General" .....	80
9.5	Cyclical command value monitoring / emergency operation.....	81
9.5.1	Command value monitoring / emergency operation parameters.....	84
9.5.2	Objects for command value monitoring / emergency operation .....	85
9.6	Command value limit .....	85
9.6.1	Command value limit parameters .....	87
9.6.2	Objects for command value limit .....	88
9.7	forced position.....	88
9.7.1	"Forced position" parameters .....	90
9.7.2	Objects for forced position.....	92
9.8	Command value status .....	92
9.8.1	Status parameters .....	96
9.8.2	Objects for status.....	97
9.9	Short-circuit and overload detection .....	98
9.9.1	Short-circuit and overload detection parameters.....	104
9.9.2	Objects for short-circuit and overload detection .....	105
9.10	Valve rinsing .....	105
9.10.1	Valve rinsing parameters.....	109
9.10.2	Objects for valve rinsing .....	111
9.11	Operating hours counter .....	112
9.11.1	Operating hours counter parameters.....	117
9.11.2	Objects for operating hours counter .....	119
<b>10</b>	<b>Room temperature controller .....</b>	<b>121</b>
10.1	Channel configuration.....	121
10.1.1	Channel configuration parameters .....	121
10.2	Room temperature controller - General .....	122
10.2.1	Name .....	122
10.2.2	Operating mode.....	122
10.2.3	Type of control.....	124
10.2.4	Disabling functions .....	134
10.2.5	Reset behaviour .....	135
10.2.6	"Room temperature controller - General" parameters .....	135
10.3	Operating mode and setpoints.....	138
10.3.1	Operating mode and setpoint parameters .....	153
10.3.2	Objects for operating mode and setpoints.....	159
10.4	Command value output and command value limit.....	164
10.4.1	Command value output parameters .....	167

10.4.2	Command value limit parameters .....	169
10.4.3	Objects for command value output and command value limit .....	170
10.4.4	Objects for command value limit .....	181
10.5	Room temperature measurement .....	181
10.5.1	Temperature measurement parameters .....	185
10.5.2	Objects for temperature measurement .....	187
10.6	Controller status .....	187
10.6.1	Status output parameters .....	190
10.6.2	Objects for controller status .....	191
10.7	Boost function .....	193
10.7.1	Boost function parameters .....	194
10.7.2	Objects for boost function .....	195
10.8	Floor temperature monitoring .....	196
10.8.1	Floor temperature monitoring parameters .....	197
10.8.2	Objects for floor temperature monitoring .....	198
10.9	Setpoint temperature limit, cooling .....	199
10.9.1	Setpoint temperature limit parameters .....	201
10.9.2	Objects for setpoint temperature limit .....	202
10.10	Setpoint temperature increase, heating .....	203
10.10.1	Setpoint temperature increase parameters .....	205
10.10.2	Objects for setpoint temperature increase .....	206
10.11	Scenes .....	206
10.11.1	Scene parameters .....	210
10.11.2	Objects for scenes .....	212
<b>11</b>	<b>Logic functions .....</b>	<b>213</b>
11.1	Logic functions parameters .....	214
11.2	Logic gate .....	216
11.2.1	Logic gate parameters .....	218
11.2.2	Logic gate object list .....	221
11.3	Converter (1 bit -> 1 byte) .....	223
11.3.1	Converter parameters .....	224
11.3.2	Converter object list .....	226
11.4	Disabling element [Filtering/Time] .....	227
11.4.1	Disabling element parameters .....	229
11.4.2	Disabling element object list .....	233
11.5	Comparator .....	234
11.5.1	Comparator parameters .....	236
11.5.2	Comparator object list .....	242

---

11.6	Limit value switch.....	245
11.6.1	Limit value switch parameters .....	247
11.6.2	Limit value switch object list .....	253
<b>12</b>	<b>As-delivered state .....</b>	<b>256</b>

## 1 Information on the product

### 1.1 Product catalogue

Product name:	Heating actuator 6-gang with controller
Use:	Actuator
Design:	RMD (rail-mounted device)
Order no.	2139 00

### 1.2 Function

#### General

The heating actuator is used for the activation of electrothermal actuators (ETA) for heating or cooling systems. It possesses 6 electronic outputs, each of which can silently activate up to 4 (AC 230 V) or 2 (AC 24 V) actuators. Both deenergised closed and deenergised opened actuators can be connected.

In addition, the actuator contains up to 12 room temperature controllers (RTC), which are integrated in the device software and which work independently of the process. The command value outputs of these controllers can be linked to the electronic valve outputs of the actuator, meaning that temperature control and valve activation can take place using just one bus device, if required. The use of external room temperature controllers (e.g. push-button sensors with RTC) is thus not absolutely essential, but is possible as the valve outputs can be activated individually via the KNX. The integrated controllers can also activate other heating actuators or fan coil actuators. The room temperature is made available to the integrated controllers via separate communication objects. All the controller functions (e.g. setpoint temperature specification, operating mode switchover, switchover of the operating mode) are controlled via KNX communication objects (object controller without its own operating elements), meaning that controller operation is possible via controller extensions or visualisations.

#### Functions of the electronic valve outputs

The heating actuator receives 1-bit or 1-byte command value telegrams, transmitted, for example, by external KNX room temperature controllers or by one of the internal controllers. The actuator controls its valve outputs either in switching form or with a PWM signal, according to the data format of the command values and the configuration in the ETS. The cycle time for constant PWM output signals can be configured separately for each valve output of the heating actuator. This allows individual adaptation to different actuator types.

On activation with constant command values, an optional command value limit can be configured, which allows the limitation of received command values at the "Minimum" and "Maximum" limits. A minimum command value can be used, for example, for the implementation of basic heating or cooling. A maximum command value allows the limitation of the effective command value range, which usually has a positive influence on the lifespan of actuators.

The heating actuator possesses a heat requirement and pump controller. This produces a positive impact on the energy consumption of a housing or commercial building through the transmission and evaluation of the largest command value in the heating or cooling system. The information on the largest active command value can be made available to suitable calorific furnaces with integrated KNX controller directly via a KNX telegram (1-byte constant), for example, to determine the optimum flow temperature. Alternatively or additionally, the heating actuator can even evaluate the command values of its outputs and make general heat requirement information available in the form of limiting value monitoring with hysteresis (1-bit, switching). Using a KNX switch actuator, this allows the energy-efficient activation of burner and boiler controllers with suitable control inputs (e.g. requirement-orientated switchover between the reduction and comfort setpoint in a central combi boiler).

The heating actuator also allows switching activation of the circulation pump of the heating or cooling circuit via a 1-bit KNX telegram. When using pump control, the pump is only switched on by the actuator when at least one command value of the outputs exceeds a limiting value with hysteresis defined in the ETS. The pump is switched off when the limiting value is reached or undershot again. This saves electrical energy, as the pump is only activated by sufficiently large, and thus effective, command values. Optional cyclical anti-sticking protection prevents the sticking of the pump, if it has not been switched on by the command value evaluation for a longer period of time.

To prevent calcification or sticking of a valve which has not been activated for some time, the actuator has an automatic valve rinsing function. Valve rinsing can be executed cyclically or using a bus command, causing the activated valves to run through the full valve stroke for a preset period of time. If necessary, the intelligent valve rinsing can be enabled. In so doing, cyclical rinsing using the full stroke is only executed when a defined minimum command value limiting value was not exceeded during actuator operation.

Cyclical monitoring of the command values can be performed as an option. If, during active cyclical monitoring, there are no command value telegrams during a preset time, then emergency operation is activated for the affected valve output, for which a configurable constant PWM command value can be preset. In addition, it is possible to activate a forced position separately for each output using a 1-bit KNX object. A defined PWM command value is set at the appropriate output.

Emergency operation and forced position can also be activated automatically in case of bus voltage failure, after bus voltage return or after an ETS programming operation. If necessary, the command values for emergency operation and the forced position can be influenced by the summer and winter mode of the actuator, allowing the activation of different heating or cooling levels according to the season. The actuator permits switchover between summer and winter mode at any time using a 1-bit object.

The heating actuator possesses comprehensive status functions. The active command value can be made available as status information, separately for each valve output.

The actuator is able to detect an overload or a short-circuit at the valve outputs and, in consequence, to protect them against destruction. Outputs which have experienced a short-circuit or a constant load are deactivated after an identification period.

In this case, a short-circuit or overload signal can be transmitted via a KNX communication object. The actuator can also signal a failure of the valve voltage on the KNX.

The switch-on times of the valve outputs can be detected and evaluated separately by operating hours counters. In addition, service operation is available, which, during maintenance or installation, can move all assigned valve drives to a defined position (completely opened or completely closed) and can lock them against activation by command value telegrams. Both service mode and the locking status are preset by a 2-bit forced operation telegram.

### **Function of the room temperature controller**

There are 12 controllers integrated into the device's software that can be used for individual room temperature control. This allows the temperature to be set in up to 12 rooms or room areas to specified setpoints through independent control processes. Depending on the operating mode, current setpoint temperature and room temperature, using a controller means that a command value for heating or cooling control can be transmitted to the KNX for the control circuit or be forwarded internally to a valve output. The controller distinguishes between different operating modes (Comfort, Standby, Night, Frost/heat protection) each with their own temperature setpoints for heating or cooling. For heating and cooling functions, you can select continuous or switching PI or switching 2-point feedback control algorithms.

In addition to the basic level heating or cooling, activating an additional level enables an additional heating or cooling unit to be used. In this connection, you can set the temperature setpoint difference between the basic and the additional level by a parameter in the ETS. For major deviations between the temperature setpoint and the actual temperature, you can activate this additional level to heat up or cool down a room faster. You can assign different control algorithms to the basic and additional levels.

The room temperatures are recorded per controller by one or optionally by two external KNX temperature sensors (e.g. push-button sensors with temperature measurement).

### **Logic functions**

In addition, the device has 8 internal logic functions. Using these functions, logic gates (e.g. AND, OR, exclusive OR, each with up to 4 inputs) can be set up and thus switching and status information can be linked and evaluated. Alternatively, a 1-bit to 1-byte converter and a disabling element with filter and time functions can be configured for each logic function. As a further option, comparators or limit value switches with hysteresis can be set as a logic function.

The logic functions have their own KNX communication objects and can process telegrams of the actuator or of other bus devices.

### **Update capability**

The device can be updated. Firmware can be easily updated with the Gira ETS Service App (additional software).



### **KNX Data Secure**

The device is KNX Data Secure capable. KNX Data Secure offers protection against manipulation in building automation and can be configured in the ETS project. Detailed specialist knowledge is required. A device certificate, which is attached to the device, is required for safe commissioning. During mounting, it is recommended to remove the certificate from the device and to store it securely.

### **ETS versions**

Planning, installation and commissioning of the device are carried out with the aid of the ETS5, version 5.7.7 or higher or of the ETS6, version 6.0.3 or higher.

### **Operation**

The operating elements (4 push-buttons) on the front panel of the device permit influencing of the electronic outputs of the actuator through manual operation, even without KNX bus voltage or in a non-programmed state (switch on and off / PWM). This feature permits a fast function check of the connected actuators. Moreover, the statuses of the outputs in case of bus voltage failure or bus voltage return and after ETS programming can be set separately.

### **Mounting and electrical connection**

The device electronics and the bus coupler are supplied from the bus voltage. The valve outputs possess a separate connection for the supply of the connected actuators (AC 24 V or AC 230 V).

The device is designed for mounting on DIN rails in closed compact boxes or in distributors in fixed installations in dry interior rooms.

- i** We recommend using electrothermal actuators of make Gira or, alternatively, models of make Möhlenhoff (AA2004, AA4004) or Sauter (MTX). Always observe the technical data of the actuators and compare them with the technical properties of the heating actuator.

### 1.3 Device components

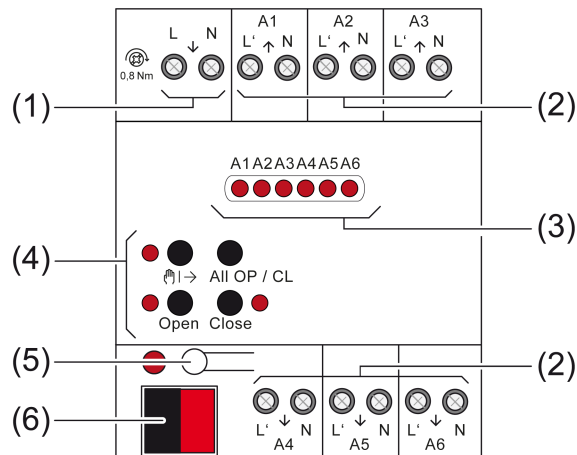

Image 1: Front view

- (1) Supply of electrothermal valve drives
- (2) Connection of electrothermal valve drives (A1 to A6)
- (3) Status LEDs for outputs
- (4) Button field for manual operation
- (5) Programming button and LED
- (6) Bus connection

**i** If all of the status LEDs (3) are flashing (2 Hz), the device is indicating that there is no power supply to the electrothermal valve drives (1).

**1.4 Technical data**

KNX	
KNX medium	TP256
Commissioning mode	S-mode
Rated voltage KNX	DC 21 ... 32 V SELV
Current consumption KNX	4.5 ... 10 mA
Ambient conditions	
Ambient temperature	-5 ... +45 °C
Storage/transport temperature	-25 ... +70 °C
Heating outputs	
Contact type	Semi-conductor (Triac), ε
Switching voltage	AC 24 / 230 V ~
Mains frequency	50 / 60 Hz
Switching current	5 ... 160 mA
Switch-on current	max. 1.5 A (2 s)
Switch-off current	max. 0.3 A (2 min)
Number of drives per output	
230 V drives	max. 4
24 V drives	max. 2
Housing	
Installation width	72 mm / 4 HP
Connection of outputs	
Connection mode	Screw terminal
Single stranded	0.5 ... 4 mm <sup>2</sup>
Finely stranded without conductor sleeve	0.5 ... 4 mm <sup>2</sup>
Finely stranded with conductor sleeve	0.5 ... 2.5 mm <sup>2</sup>
Connection torque, screw terminals	max. 0.8 Nm

## 2 Safety instructions



Electrical devices may only be mounted and connected by electrically skilled persons.

Failure to observe the instructions may cause damage to the device and result in fire and other hazards.

Danger of electric shock. Device is not suitable for disconnection from supply voltage. The load is not electrically isolated from the mains even when the device is switched off.

Danger of electric shock. Always disconnect before carrying out work on the device or load. In so doing, take all the circuit breakers into account, which support dangerous voltages to the device and or load.

Danger of electric shock. Make sure during the installation that there is always sufficient insulation between the mains voltage and the bus. A minimum distance of at least 4 mm must be maintained between bus conductors and mains voltage cores.

The device may not be opened or operated outside the technical specifications.

### 3 Mounting and electrical connection

---



#### **DANGER!**

Electric shock when live parts are touched.

Electric shocks can be fatal.

Before carrying out work on the device or load, disengage all the corresponding circuit breakers. Cover up live parts in the working environment.

---

#### **Mounting the device**

- Enter or scan the device certificate and add it to the project. A high resolution camera should be used to scan the QR code.
- The device certificate should be removed from the device during mounting.
- Document all passwords and keep them safe.

Observe ambient temperature. Ensure adequate cooling.

- Mount device on DIN rail.

#### **Connecting the device**

Connect either AC 230 V or AC 24 V valve drives to all the outputs.

Only connect valve drives with the same characteristics to each output (deenergised closed/opened).

Do not connect any other loads.

Connect valve drives for frost-sensitive rooms to outputs A1 and A4. These are switched off last in the event of overload.

Do not exceed maximum number of valve drives per output (siehe Kapitel "Technical data" ▶ Page 11).

Observe the technical data of the valve drives used.

Do not connect the neutral conductor from the output terminals through to additional devices.

- Connect AC 230 V valve drives according to the connection diagram (see figure 2).

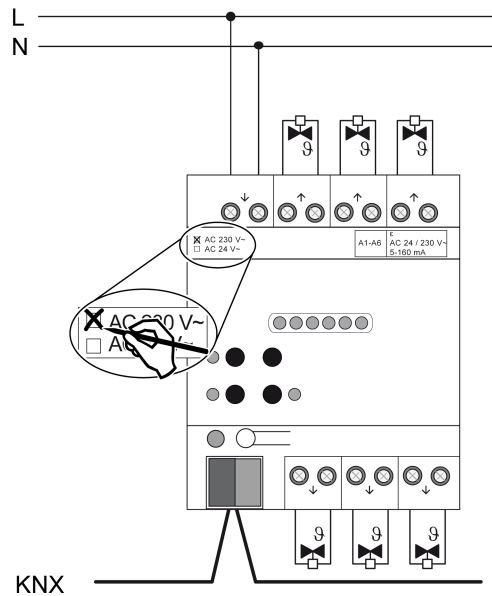

Image 2: Connection of 230 V valve drives

- Connect AC 24 V valve drives according to the connection diagram (see figure 3).

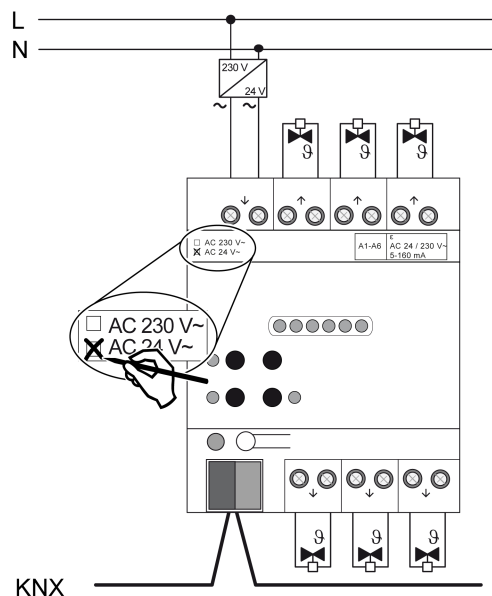

Image 3: Connection of 24 V valve drives

- Connect the supply for the valve drives to the terminals ↓(L) and ↓(N) (1).
- Connect bus line with device connection terminal.

## 4 Commissioning

The device is commissioned with the ETS version 5.7.7 or higher.

### Safe-state mode

The safe-state mode stops the execution of the loaded application program.

- i** Only the system software of the device is still functional. ETS diagnosis functions and programming of the device are possible. Manual operation is not possible.

### Activating safe-state mode

- Switch off the bus voltage or remove the KNX device connection terminal.
- Wait about 15 s.
- Press and hold down the programming button.
- Switch on the bus voltage or attach the KNX device connection terminal. Release the programming button only after the programming LED starts flashing slowly.

The safe-state mode is activated.

By briefly pressing the programming button again, the programming mode can also be switched on and off in the safe-state mode as usual. If the programming mode is active, the programming LED stops flashing.

### Deactivating safe-state mode

- Switch off bus voltage (wait approx. 15 s) or carry out ETS programming.

### Master reset

The master reset restores the basic device settings (physical address 15.15.255, firmware remains in place). The device must then be recommissioned with the ETS. Manual operation is possible.

In secure operation: A master reset deactivates device security. The device can then be recommissioned with the device certificate.

### Performing a master reset

Precondition: The safe-state mode is activated.

- Press and hold down the programming button for > 5 s.  
The programming LED flashes quickly.

The device performs a master reset, restarts and is ready for operation again after approx. 5 s.

**Restoring the device to factory settings**

Devices can be reset to factory settings with the Gira ETS Service App. This function uses the firmware contained in the device that was active at the time of delivery (as-delivered state). Restoring the factory settings causes the devices to lose their physical address and configuration.



## 5 Application programs

ETS search paths: heating, air condition / valves / Heating actuator, 6-gang with controller

### **Application:**

Name	Heating actuator 6-gang 20E021
Version	2.1 for ETS5 version 5.7.7 or higher and ETS6 version 6.0.3 or higher
from mask version	SystemB (07B0)
Summarized description	Multifunctional heating actuator application: Activation of up to 6 valve outputs for electrothermal actuators. Optionally with room temperature control through 12 integrated room temperature controllers. With logic functions and manual operation. KNX Data Secure capable.

## 6 Scope of functions

### Valve outputs

- 6 independent electronic valve outputs.
- Valve activation (deenergised opened / closed) can be configured for each output.
- Command value evaluation as "Switching, 1-bit", "Constant, 1-byte" or "Constant, 1-byte with command value limiting value and hysteresis".
- With a 1-byte command value, the outputs are activated by pulse width modulation (PWM). The cycle time can be configured for each valve output.
- Status feedback (1 bit or 1 byte) of each output possible automatically or on read request.
- Failure signal of the valve operating voltage can be configured (1-bit).
- Overload and short-circuit signal can be set separately via a 1-bit object for each valve output (polarity can be configured). Global reset of all short-circuit / overload signals possible.
- Heat requirement and pump control, for positive influencing of the energy consumption of a housing or commercial building. Provision of the largest active command value directly via KNX telegram (1-byte constant). Alternatively or additionally, evaluation of the actuator command values for provision of the general heat requirement information in the form of limiting value monitoring with hysteresis (1-bit switching). Activation of a circulation pump of the heating or cooling circuit via a 1-bit KNX telegram with limiting value evaluation. Optional cyclical anti-sticking protection prevents the sticking of the pump.
- Summer or winter mode can be selected via an object (polarity configurable).
- Each valve output can be locked in a forced position with bus control. Different command values can be configured for summer and winter mode.
- Cyclical monitoring of the command value of each output can be set, taking into account a configurable monitoring time. If no command value telegram is received within the preset monitoring time, the valve output concerned switches to emergency operation. Different command values can be configured for summer and winter mode. The fault telegram is configurable.
- On activation with constant command values, an optional command value limit can be configured, which allows the limitation of received command values at the "Minimum" and "Maximum" limits.
- Automatic valve rinsing to prevent calcification or sticking of a valve which has not been activated for some time.
- Operating hours counter to record the switch-on times of the valve outputs.
- Service mode for the maintenance or installation of valve drives (locking of the valve outputs in a defined state). Both service mode and the locking status are preset by a 2-bit forced operation telegram.

- Manual operation of outputs independent of the KNX (for instance, construction site mode) with LED status indicators. Separate status feedback to the KNX for manual operation. Manual operation can also be disabled via the KNX. Own cycle time and PWM setting for manually-operated valve outputs. Central activation of all valve outputs (0% / 100%).
- Behaviour in case of bus voltage failure and bus voltage return as well as after ETS programming settable for each valve output.
- Various actively transmitting status signals can be delayed globally after bus voltage return or after an ETS programming operation.
- The parameters of the outputs can be set individually (each valve output possesses its own parameters) or alternatively like valve output 1.

### **Room temperature controller**

- Up to 12 independent room temperature controllers.
- Individual control of a controller using communication objects.
- Various operating modes can be activated: Comfort, Standby, Night and Frost/heat protection
- Each operating mode can be assigned its own temperature setpoints (for heating and/or cooling).
- Configuring the temperature setpoints as relative (derived from basic setpoint) or absolute (independent setpoint temperatures for each operating mode).
- Comfort extension possible using presence button in Night or Frost/heat protection mode. Configurable duration of the comfort extension.
- The operating modes are switched over via 1-byte objects according to the KNX specification.
- Status feedback telegrams can be configured.
- Frost/heat protection switchover via window status or by automatic frost protection.
- Operating modes "Heating", "Cooling", "Heating and cooling" each with or without additional level. The temperature setpoints for the additional level are derived via a configurable level offset from the values of the basic level.
- Various control types can be configured for each heating or cooling level: PI control (permanent or switching PWM) or 2-point feedback control (switching).
- Control parameter for PI controller (if desired: proportional range, reset time) and 2-point controller (hysteresis) adjustable.
- Automatic or object oriented switchover between "heating" and "cooling".
- A temporary or permanent setpoint shift for a relative setpoint specification through communication objects is possible (e.g. via a controller extension).
- Configurable step width of the setpoint shift (0.1 K / 0.5 K).
- Deactivating the feedback control or the additional level possible using separate 1-bit objects.

- Room temperature measurement via up to two external KNX temperature sensors. Calibration of the temperature values possible and measured value formation of the external sensors can be configured. Settable polling time of the externally received temperature values.
- The actual and setpoint temperatures can be output on the bus if a configurable deviation is detected (also periodically).
- Separate or shared command value output in heating and cooling mode. This produces one or two command value objects for each level.
- Normal or inverted command value output configurable
- Automatic transmission and cycle-time for command value output configurable
- Command value limit possible.
- Floor temperature limit possible in cooling mode and heating mode. Thus temperature-controlled switch-off of underfloor heating and cooling as protective function.
- Setpoint temperature limit possible in cooling mode. If necessary, the controller limits the setpoint temperature to specific values and prevents an adjustment beyond statutory limits.
- Setpoint temperature increase possible in heating mode. If necessary, the controller raises the setpoint temperature in accordance with the outdoor temperature.

## **7 Notes on software**

### **Unloading the application program**

The application program can be unloaded with the ETS. In this case, all valve outputs of the product are switched off. Manual operation is possible.

### **ETS project design and commissioning**

For project design and commissioning of the device, ETS5 version 5.7.7 or higher or ETS6 version 6.0.3 or higher is required.

### **Safe-state mode**

If the device does not work properly - for instance as a result of errors in the project design or during commissioning - the execution of the loaded application program can be halted by activating the safe-state mode. In safe-state mode, activation of the valve outputs via the KNX or manual operation is not possible. The room temperature controllers also have no function. The actuator remains passive in safe-state mode, since the application program is not being executed (state of execution: Terminated). Only the system software is still functional so that the ETS diagnosis functions and also programming of the device continue to be possible.

## 8 Operation and indication

### 8.1 Button operation and indication functions

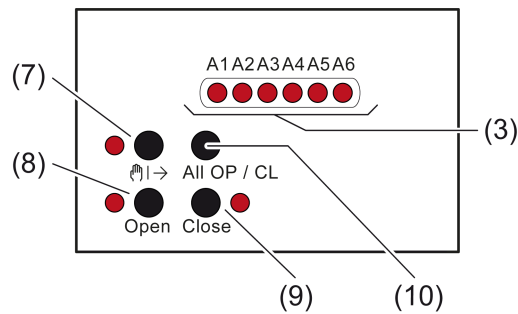

Image 4: Operating elements

- (3) **A1...A6:** status LED outputs (LEDs light up when outputs are energised)
- (7) button: activation / deactivation of manual operation  
LED - On: permanent manual operation mode active
- (8) **Open** button: open valve (configured valve direction of action is taken into account)  
LED – On: valve opened, manual operation mode
- (9) **Close** button: close valve (configured valve direction of action is taken into account)  
LED – On: valve closed, manual operation mode
- (10) **ALL OP / CL** button: central operating function for all valve outputs. Open and close all the valves alternately.

**i** **OPEN (8) and CLOSE (9) LEDs:** The LEDs light up statically during manual operation, showing the valve status set or to be set (valve is closed or closing / valve is opened or opening). Even on valve outputs working with an 8-bit command value (PWM), the LEDs display the logical valve state statically in the same way. The LEDs do not signal the dynamic switch-on and switch-off phases of the pulse width modulation.  
If no valve voltage is connected or switched on at the terminals ↓(L) and ↓(N), then the LEDs are also always switched off, even if bus voltage is available, as the valve outputs cannot be energised.

#### Status indication

The status LEDs **A1...A6 (3)** show whether the current flow is switched on or switched off at the appropriate output. The connected heating or cooling valves open and close according to their characteristics.

Valve drive	LED ON	LED OFF
Deenergised closed	Output energised Valve opened / Opening phase Active heating or cooling	Output not energised Valve closed / Closing phase

Valve drive	LED ON	LED OFF
Deenergised opened	Output energised Valve closed / Closing phase	Output not energised Valve opened / Opening phase Active heating or cooling

- LED flashes slowly: output in manual operation mode
  - LED flashes quickly: output disabled via permanent manual operation mode
- i** In the case of valve outputs working with an 8-bit command value (PWM), the LEDs dynamically display the switch-on and switch-off phases of the pulse width modulation.
- i** If no valve voltage is connected or switched on at the terminals  $\downarrow L$  and  $\downarrow N$  (1), then all status LEDs are also always switched off, even if bus voltage is available, as the valve outputs cannot be energised.
- i** On the LED status display, the valve direction of action configured for each output in the ETS is not taken into account. As a result, the LEDs do not immediately display the valve state (opened / closed). Inversion of the status display according to the valve direction of action thus does not take place.

The manual operation of the actuator distinguishes between the following operating modes:

- Bus operation: Operation via room temperature controllers, push-button sensors, or other bus devices,
  - Temporary manual operation mode: manual operation locally with keypad, automatic return to bus control,
  - Permanent manual operation mode: exclusively manual operation on the device (e.g. construction site mode, commissioning phase).
- i** When manual operation mode is active, the outputs cannot be controlled via the bus.
- i** In case of bus voltage failure, manual operation mode is not possible.
- i** In manual operation mode, bus operation can be disabled via a telegram. Manual operation mode is terminated on activation of the disabling function.
- i** No manual operation of the device is possible if the actuator is programmed by the ETS with an incorrect application program or if the application program was unloaded. In the as-delivered state of the actuator, manual operation can be used even before commissioning via the ETS (construction site mode).
- i** Further details concerning manual operation, especially with respect to the possible parameter settings and the interaction with other functions of the actuator can be found in the chapter "Valve outputs" of the present documentation.

### Switching on temporary manual operation mode

Manual operation is enabled in the ETS and not blocked.

- Press the  button briefly.

Temporary manual operation mode is active.

The status LED **A1** flashes. The LED  flashes.

- i** After temporary manual operation mode has been switched on, the most recently set states of the outputs initially remain active. For opened valve outputs, the pulse width modulation is not adjusted to the preset value of manual operation. This only takes place when the valves are first closed and then re-opened, in the course of brief manual operation.
- i** After 5 seconds without a button actuation, the actuator returns automatically to bus operation.

### Switching off temporary manual operation mode

The device is in temporary manual operation mode.

- No button has been actuated for 5 seconds.  
- or -
- Select all outputs one after another by a brief press of the  button. Thereafter, press the button again,  
- or -
- switch off the bus voltage.  
- or -

Bus operation is active. LEDs **A1...A6** no longer flash, but rather indicate the output status.

- i** Manual operation is always exited after an ETS programming operation.
- i** The state of all outputs set via manual operation is not changed when temporary manual operation mode is switched off. If, however, a function with a priority higher than that of normal operation (e.g. forced position, safety operation) was activated for the valve outputs via the bus before or during manual operation, the actuator executes the function with the higher priority for the outputs concerned.

### Switching on permanent manual operation mode

Manual operation is enabled in the ETS and not blocked.

Bus operation or temporary manual operation mode is active.

- Press the  button for at least 5 seconds.



Permanent manual operation mode is active and the LED |→ is illuminated. The status LED **A1** flashes. The two status LEDs **OPEN** and **CLOSE** show the current status of A1.

- i** After permanent manual operation mode has been switched on, the states of the outputs last set initially remain active. However, for opened valve outputs, the pulse width modulation is automatically adjusted to the preset value of manual operation.

### Switching off permanent manual operation mode

The device is in permanent manual operation mode.

- Press the |→ button for at least 5 seconds.  
- or -
- switch off the bus voltage.  
- or -
- Block manual operation via the corresponding disabling object,  
- or -

Bus operation is active. LEDs **A1...A6** no longer flash, but rather indicate the output status.

- i** Manual operation is always exited after an ETS programming operation.
- i** Depending on the configuration of the actuator in the ETS, the outputs will be set to the state last adjusted in manual operation or to the state internally tracked (e.g. forced position, service operation) when permanent manual operation mode is switched off.

### Operating the outputs

In manual operation mode the outputs can be operated instantly. The outputs are always activated with pulse width modulation by manual operation with the **OPEN** command. The cycle time of the PWM signal for a valve output activated by manual operation is configured centrally on the parameter page "Manual operation" in the ETS. The **CLOSE** command closes the valves completely (0%).

The device is in permanent or temporary manual operation mode.

- Press the |→ button briefly, < 1 s, as many times as necessary until the desired output is selected.  
The LED of the selected output **A1...A6** flashes. Additionally, the status of the selected output is indicated by the LED **OPEN** or **CLOSE**.
- Press the **OPEN** button.  
The valve opens (configured valve direction of action is taken into account).
- Press the **CLOSE** button.

The valve closes (configured valve direction of action is taken into account).

The LEDs **OPEN** and **CLOSE** display the valve status.

- i** Temporary manual operation mode: After running through all of the outputs, the device exits manual operation mode after the  button is briefly pressed again.
- i** Executing the **OPEN** command when valves are already opened causes no reaction. The cycle time of a PWM signal is not restarted. On previously closed valves, pressing the **CLOSE** button also does not produce a reaction.
- i** Depending on the parameter configuration in the ETS, feedback telegrams are transmitted to the bus via the status objects of an output during operation, as necessary.

### Operating all outputs simultaneously

All the valve outputs of the actuator can be activated at the same time. In contrast to the operating function using the **OPEN** or **CLOSE** buttons, the actuator always activates the valve outputs with a constant signal (0% or 100%), when they are activated simultaneously. This causes the valves to close or open completely. No pulse width modulation is executed.

This operating function is particularly practical for performing the First Open function of deenergised closed valves during first commissioning.

The device is in permanent manual operation mode.

- Press the **ALL OP / CL** button.  
Each time the button is pressed, the valves open and close alternately, depending on the status of the valve output currently selected (all open -> all close -> all open...). The configured valve direction of action is taken into account.
- i** Executing the **OPEN** central command when valves are already opened causes PWM to be terminated. The command value switches to 100%. The cycle time of a PWM signal is not restarted. On previously closed valves, executing the **CLOSE** central command does not produce a reaction.
- i** The **ALL OP / CL** button has no function in temporary manual operation mode. In this case pressing this button produces no reaction.

### Disabling bus control of individual outputs via manual operation

It is possible to use manual operation to disable selected valve outputs in such a way that they can no longer be activated via the bus.

The device is in permanent manual operation mode.

Disabling of the bus control mode must have been enabled in the ETS.

- Press the  button briefly as many times as necessary until the desired output is selected.

The status LED of the selected output **A1...A6** flashes. The two status LEDs **OPEN** and **CLOSE** show the current status of the selected output.

- Press the **OPEN** and **CLOSE** buttons simultaneously for at least 5 seconds. The selected valve output is disabled (activation via the bus no longer possible). The status LED of the disabled output flashes quickly and constantly (even with manual operation deactivated).

**i** An output that has been disabled in manual operation can thereafter only be operated in permanent manual operation mode.

### **Cancelling the disabling of bus control of individual outputs via manual operation**

The device is in permanent manual operation mode.

Bus control of a valve output has been disabled previously in permanent manual operation mode.

- Press the |→ button briefly as many times as necessary until the desired output is selected.

The status LED of the selected output **A1...A6** flashes quickly. The two status LEDs **OPEN** and **CLOSE** show the current status of the selected output.

- Press the **OPEN** and **CLOSE** buttons simultaneously for at least 5 seconds. Selected output is enabled.

The selected valve output is re-enabled (activation via the bus is possible again after manual operation has been deactivated).

The status LED of the enabled output flashes slowly.

## 8.2 ETS configuration

### 8.2.1 Manual operation

All outputs of the device have electronic manual operation. The button field with 4 function buttons and 3 status LEDs on the front panel of the device can be used for setting the following modes of operation:

- Bus operation: operation via push-button sensors or other bus devices
- Temporary manual operation mode: manual operation locally with button field, automatic return to bus operation
- Permanent manual operation mode: local manual operation with keypad

Manual operation is possible while the device is supplied with power from the bus supply voltage. In the as-delivered state, manual operation is fully enabled. In this un-programmed state, all the outputs can be controlled by manual operation, so that fast function checking (e.g. on the construction site) is possible.

After initial commissioning of the actuator via the ETS, manual operation can be enabled or completely disabled.

#### Disabling manual operation permanently

Manual operation is enabled in the as-delivered state. If the parameter of the same name is deactivated on the "Manual operation" parameter page, no parameters and communication objects for manual operation are available. The outputs can then only be controlled via the bus.

In the case of a temporary status indication, the status LEDs continue to indicate the status of the outputs when the "Manual operation" button is pressed.

#### Disabling manual operation temporarily

Manual operation can be separately disabled via the bus, even if it is already active. If the disabling function is enabled, then as soon as a disabling telegram is received via the disabling object, the actuator immediately terminates any activated manual operation and locks the function keys on the front panel of the device. The telegram polarity of the disabling object is parameterisable.

Manual operation must be enabled.

- Activate the parameter "Disabling function" on the "Manual operation" parameter page.

The disabling function of manual operation is enabled and the disabling object becomes visible.

- Select the desired telegram polarity in the parameter "Object polarity".

**i** If the polarity is "0 = disabled / 1 = enabled", the disabling function is immediately active on bus voltage return or after an ETS programming operation (object value "OFF"). To activate manual operation in this case, an enable telegram "ON" must first be sent to the disabling object.

- i** After return of bus voltage, a disabled state that was active beforehand is always inactive when the polarity of the disabling object is non-inverted.
- i** When an active manual operation is terminated by a disable, the actuator will also transmit a "Manual operation inactive" status telegram to the bus, if the status messaging function is enabled.

### Presetting the behaviour at the beginning and at the end of manual operation

Manual operation distinguishes between the temporary and permanent manual operation modes. The behaviour is different depending on these operating modes, especially at the end of manual operation. It should generally be noted that bus operation is always disabled while the manual operation mode is active. This means that manual operation has the highest priority.

Behaviour at the beginning of manual operation:

The behaviour at the beginning of manual operation does not differ for temporary and permanent manual operation modes. On activation of manual operation mode, the most recently set states of the outputs initially remain active. Active functions such as forced position, valve rinsing, and service operation can be overridden by manual operation. These functions are reactivated after deactivation of the manual operation mode unless they have been cancelled in the meantime via the KNX. Then the function with the higher priority is always executed.

Behaviour at the end of manual operation:

The behaviour at the end of manual operation is different for temporary and permanent manual operation modes. The temporary manual operation mode is shut off automatically when the last output has been addressed and when the selection button  is pressed once more. During deactivation of the temporary manual operation mode, the actuator returns to 'normal' bus operation and does not change the states selected by manual control. If, however, a function such as forced position, valve rinsing or service operation has been activated via the KNX before or during manual operation, the actuator executes these functions with higher priority again for the affected outputs.

The permanent manual operation mode is shut off when the selection button  is pressed for more than 5 seconds. Depending on the configuration of the actuator in the ETS, the outputs will be set to the state last adjusted in manual operation or to the state internally tracked when permanent manual operation mode is switched off. The parameter "At end of permanent manual operation" defines the corresponding reaction.

- Set the parameter "At end of permanent manual operation" to "no change".  
All telegrams received during active permanent manual operation for direct operation will be rejected. After the end of permanent manual operation, the current state of all outputs remains unchanged. If, however, a forced position, a valve rinsing or a service operation has been activated via the KNX before or during manual operation, the actuator executes these functions with a higher priority for the affected outputs.
- Set the parameter "At end of permanent manual operation" to "track outputs".

During active permanent manual operation, all incoming telegrams are tracked internally. At the end of manual operation, the outputs will be set to the tracked states or to the positions last set before the permanent manual operation. The individual priorities of the functions with respect to one another are taken into account here. Only the function with the greater priority is executed.

- i** The operations triggered during manual operation update the states of the feedback and status objects. Telegrams are also transmitted to the KNX, if the signal objects concerned are enabled in the ETS and are configured as actively transmitting.
- i** During an ETS programming operation, an activated manual operation mode will always be terminated. In this case, the parameterised or predefined behaviour at the end of manual operation will not be executed. The actuator executes the configured behaviour after ETS programming instead.

### **Presetting the status message function for manual operation**

An actuator can transmit a status telegram to the KNX via a separate object when the manual operation is activated or deactivated. The status telegram can only be transmitted when the bus voltage is switched on. The polarity of the status telegram can be parameterised.

Manual operation must be enabled.

- Activate the parameter "Status object" on the "Manual operation" parameter page.  
The status messaging function of manual operation is enabled and the status object is visible.
- Specify in the parameter "Function" whether the status telegram is generally an "ON" telegram whenever manual operation is activated or only in those cases where permanent manual operation is activated.
- i** The status object is always "OFF" when the manual operation is deactivated.
- i** The "inactive" status is transmitted automatically to the bus after bus voltage return or an ETS programming operation.
- i** When active manual operation is terminated by a disable, the actuator will also transmit a "Manual operation inactive" status telegram to the bus.

### **Setting disabling of the bus control**

Individual outputs can be disabled locally by manual operation on the device so that the connected valves can no longer be controlled via the KNX. Such disabling of the bus operation is initiated by operation in permanent manual operation mode and is indicated by rapid flashing of the status LEDs on the front panel of the device. The disabled outputs can then only be activated in permanent manual operation.

Manual operation must be enabled.

- Activate the parameter "Disable bus control of individual outputs" on the parameter page "Manual operation".

The function for disabling the bus control is enabled and can be activated locally. Alternatively, deactivating the parameter prevents disabling of the bus control from being activated in permanent manual operation mode.

- i** The disabling initiated locally has the highest priority. Thus all other functions of the actuator that can be activated via KNX (e.g. forced position, valve rinsing or service operation) are overridden. The bus-disabled output remains in the state last set in permanent manual operation mode.  
Depending on the configuration of the actuator in the ETS, the groups will be set to the state most recently set or internally tracked after the disabling and subsequent deactivation of permanent manual operation mode.
- i** The disabling function of manual operation does not influence bus-disabled outputs.
- i** A failure of the bus voltage or an ETS programming operation deactivates disabling of the bus control.

## 8.2.2 Status indication

The status LEDs on the front of the device can indicate the current status of the outputs permanently or temporarily.

- Continuous status indication:  
The parameter "Indicate status temporarily" on the "Status indication" parameter page is deactivated. In the case of a continuous status indication, the status LEDs always indicate the current status of the outputs.
- Temporary status indication:  
The parameter "Indicate status temporarily" on the "Status indication" parameter page is activated. During temporary indication, the status indication is activated by pressing the "Manual operation" button. The display length is set in the ETS.  
If manual operation is enabled in the ETS, pressing the "Manual operation" button also activates the temporary or permanent manual operation mode. The status indication always remains active during manual operation. At the end of manual operation mode, the display length of the temporary status indication is restarted. The status LEDs then go out after the configured time has elapsed.  
If manual operation is not enabled in the ETS, all status LEDs only show the status of the outputs when the "Manual operation" button is pressed, depending on the duration of the display.

- i** In the as-delivered state, the continuous status indication is preset.

If the parameter "Control via object" is activated, the "Temporary status indication" communication object is available in the ETS. This object is bidirectional and can firstly signal the status of the temporary status indication, and secondly, activate the



status display. If a temporary status indication has been activated by pressing the "Manual operation" button, the object transmits the value "ON". If the object receives a telegram with the value "OFF" or "ON", the status LEDs indicate the status of the outputs according to the display length. Manual operation is not activated in this case.

By linking the "Temporary status indication" objects of several actuators using a common group address, the indication functions of the status LED can be synchronized with one another. It is thus possible to activate the status indications of all actuators in a control cabinet at the same time if manual operation is triggered on one actuator only - e.g. for service or maintenance purposes.

In addition, the "Temporary status display" object could be controlled, for example, by a magnetic contact connected to the KNX, so that the status indications of all actuators are activated by opening the control cabinet door. If the door is closed, the status indications for energy saving remain switched off.

- i** During a running display length, the "Temporary status indication" object does not transmit any new telegrams if the "Manual operation" button is pressed again.



### 8.3 Operation and indication parameters

#### Manual operation

Manual operation	Checkbox (yes / no)
Manual operation is possible while the device is supplied with power from the bus supply voltage. This parameter defines whether manual operation is to be possible or deactivated permanently.	
PWM cycle time	0.5 minutes 1 minute 1.5 minutes 2 minutes ... 19.5 minutes <b>20 minutes</b>
During manual operation, all the valve outputs are activated with a pulse-width modulation (PWM) using the OPEN button, irrespective of the configured command value data format (1-bit or 1-byte). The cycle time of the PWM signal for a valve output activated by manual operation is configured by this parameter. In consequence, manual operation locally on the device can allow the use of a different cycle time than in normal operation of the actuator (activation via KNX telegrams). The CLOSE command always closes the valves completely (0%). An exception is the central operating function of all valve outputs with the ALL OP / CL button. Here, the actuator always activates the valve outputs with a constant signal (0% or 100%).	
PWM command value	5... <b>50</b> ...100 %
This parameter specifies the pulse-pause ratio of the pulse width modulation of the manual operation for opened valve outputs.	
disabling function	Checkbox (yes / no)
Manual operation can be disabled via the KNX, even if it is already active. For this purpose, the disabling object can be enabled here. This parameter is only visible if manual operation is enabled.	
Object polarity	<b>0 = enabled / 1 = disabled</b> 0 =disabled/ 1 = enabled
This parameter sets the polarity of the disabling object. This parameter is only visible if the disabling function is enabled.	
Status object	Checkbox (yes / no)
An actuator can transmit a status telegram to the KNX via a separate object when the manual operation is activated or deactivated. This parameter is only visible if manual operation is enabled.	

Function	0 = inactive; 1 = manual operation active 0 = inactive; 1 = permanent manual operation active
<p>This parameter defines the information contained in the status object. The object is always "OFF" when manual operation is deactivated.</p> <p>0 = inactive; 1 = manual operation active: The object is "ON" when manual operation is active (temporary or permanent).</p> <p>0 = inactive; 1 = permanent manual operation active: The object is only "ON" when permanent manual operation is active.</p> <p>This parameter is only visible if the status function is enabled.</p>	

At end of permanent manual operation	no change Output tracking
<p>The behaviour of the actuator at the end of permanent manual operation depends on this parameter. This parameter is only visible if manual operation is enabled.</p> <p>no change: All telegrams received during active permanent manual operation for direct operation (switching, long-time/short-time, positioning, central, scenes, command value telegrams) will be rejected. After the end of the permanent manual operation, the current state of all outputs which was most recently active in manual operation remains unchanged. If, however, a forced position, a disabling function, a safety function or a sun protection function (independent of priority) has been activated via the KNX before or during manual operation, the actuator executes these functions with a higher priority for the outputs concerned.</p> <p>Track outputs: During active permanent manual operation, all incoming telegrams (blinds operation exception: short-time telegrams – step/stop) are internally tracked. At the end of the manual operation, the outputs will be set to the tracked states or to the positions last set before the permanent manual operation for Venetian blind outputs. The individual priorities of the functions with respect to one another are taken into account here. Only the function with the greater priority is executed. Long time operation is not tracked in Venetian blind operation if the corresponding Venetian blind output is already in the appropriate end position.</p> <p>This parameter is only visible if manual operation is enabled.</p>	

Bus control of individual outputs can be disabled	Checkbox (yes / no)
<p>Individual outputs can be disabled locally during permanent manual operation, so that the disabled outputs can no longer be controlled via the KNX. Disabling via manual operation is only permitted if this parameter is activated.</p> <p>This parameter is only visible if manual operation is enabled.</p>	

Status indication

Indicating status temporarily	Checkbox (yes / no)
<p>The status LEDs on the front of the device can indicate the current status of the outputs permanently or temporarily.</p> <p>Parameter deactivated: Continuous status indication. In this case, the status LEDs always indicate the current status of the outputs.</p> <p>Parameter activated: Temporary status indication. In this case, the status indication is activated by pressing the "Manual operation" button. The display length is set in the ETS. If manual operation is enabled in the ETS, pressing the "Manual operation" button also activates the temporary or permanent manual operation mode. The status indication always remains active during manual operation. At the end of manual operation mode, the display length of the temporary status indication is re-started. The status LEDs then go out after the configured time has elapsed.</p>	
Display length	6 ... 10 ... 255 s
<p>This parameter defines the display length if the temporary status indication is activated.</p>	
Control via object	Checkbox (yes / no)
<p>If the parameter "Control via object" is activated, the "Temporary status indication" communication object is available in the ETS. This object is bidirectional and can firstly signal the status of the temporary status indication, and secondly, activate the status display. If a temporary status indication has been activated by pressing the "Manual operation" button, the object transmits the value "ON". If the object receives a telegram with the value "OFF" or "ON", the status LEDs indicate the status of the outputs according to the display length. Manual operation is not activated in this case.</p>	

### 8.4 Operation and indication object list

Object no.	Function	Name	Type	DPT	Flag
1	Disabling	Manual operation - Input	1-bit	1,003	C, (R), W, -, A
1-bit object for disabling manual operation on the device. The polarity can be configured.					
Object no.	Function	Name	Type	DPT	Flag
2	Status	Manual operation - Output	1-bit	1,002	C, R, -, T, A
1-bit object for manual operation status transmission. The object is "OFF" when manual operation is deactivated (bus control). The object is "ON" when manual operation is activated. You can configure whether temporary or permanent manual operation will be indicated as status information or not.					
Object no.	Function	Name	Type	DPT	Flag
3	Temporary status indication	Manual operation - Input/Output	1-bit	1,002	C, (R), W, T, A
1-bit object to signal and activate the temporary status indication. This object is bidirectional and can firstly signal the status of the temporary status indication, and secondly, activate the status display. If a temporary status indication has been activated by pressing the "Manual operation" button, the object transmits the value "ON". If the object receives a telegram with the value "OFF" or "ON", the status LEDs indicate the status of the outputs according to the display length. Manual operation is not activated in this case. The object is only visible if the temporary status indication is activated					

## 9 Valve outputs

### 9.1 Priorities for valve outputs

The heating actuator distinguishes between various functions and events, which either affect all of some of the assigned valve drives globally, or only specifically affect individual outputs. Because these functions and events cannot be executed simultaneously, there must be priority control. Each global or output-orientated function and each incoming event possesses a priority. The function or the event with the higher priority overrides the lower-priority functions and events.

The following priorities are defined...

- Overload / short-circuit (highest priority)
- Manual operation
- Behaviour after ETS programming
- Response to bus voltage return
- Service mode
- Valve rinsing
- forced position
- Command value limit
- Emergency operation (through cyclical monitoring of the command value)
- Normal operation (activation using command value telegrams)

**i** The behaviour after an ETS programming operation is only executed if there have been changes in the configuration of the device. If just an application download is executed with a project design already located in the actuator, then the actuator will execute the behaviour after bus voltage return.

In manual operation and in service mode, a parameter separately defines the behaviour of each of the valve outputs at the end of these functions. The heating actuator only then executes the configured behaviour if, at the time of enabling, no function with a lower priority is active. Should a lower-level function be active (e.g. forced position), then the actuator will execute the behaviour of this function again.

**i** Special case: A function with a higher priority (e.g. manual operation) is active. Before this, a function with a lower priority (e.g. service mode) was active. This function is deactivated whilst the higher-level function remains active. At the end of the higher-priority function, the state of the outputs should be tracked. The actuator then evaluates the command value of the lower-level function and checks how the behaviour is preset or configured here. The actuator then executes the command value presetting of the lower-level function. If tracking is also preset or configured for this function, the actuator will still go one layer lower and evaluate the behaviour configured there.

Example 1: Service mode is active (valve completely opened / 100% command value). A value of 10% was most recently preset via a command value telegram (normal operation). No other functions are active. Service mode is

configured in such a way that the starting state should be tracked at the end of this function.

Permanent manual operation is now activated. The actuator assumes the command value of manual operation (e.g. 50%). Whilst manual operation is active, service mode is deactivated via the KNX. The actuator remains in manual operation until this is exited via the button field. As no more lower-level functions are active, the heating actuator evaluates the parameter "Behaviour at the end of permanent manual operation during bus operation". As this parameter is set to "Track outputs", the actuator now evaluates the command value to be tracked. For this, it checks how the behaviour at the end of service mode is preset. Here too, the state should be tracked. Thus, the actuator evaluates the other lower-level functions. As no other functions were and are activated, the actuator sets the last command value presetting at the valve output using the KNX telegram (here 10%).

Example 2: Service mode is active (valve completely opened / 100% command value). A value of 10% was most recently preset via a command value telegram (normal operation). No other functions are active. Service mode is configured in such a way that no change should be executed at the end of this function.

Permanent manual operation is now activated. The actuator assumes the command value of manual operation (e.g. 50%). Whilst manual operation is active, service mode is deactivated via the KNX. The actuator remains in manual operation until this is exited via the button field. As no more lower-level functions are active, the heating actuator evaluates the parameter "Behaviour at the end of permanent manual operation during bus operation". As this parameter is set to "Track outputs", the actuator now evaluates the command value to be tracked. For this, it checks how the behaviour at the end of service mode is preset. There, the configuration states that there should be no change. Thus, the heating actuator for the affected valve output assumes the command value of service mode (here 100%) and sets this at the output. In this case, the actuator no longer evaluates other lower-level functions.

## 9.2 Channel configuration

To simplify project design, all valve outputs can be activated or deactivated individually in the ETS. Parameters and communication objects of the deactivated channels are hidden.

To simplify further, the valve outputs can be assigned to the same parameters and thus configured identically. The parameter "Parameterisation" stipulates whether every valve output of the device can be configured individually or whether the parameters of valve output 1 are to be applied.

With the setting "like VO 1", the parameter pages in the ETS are reduced. The visible parameters of the first valve output are then automatically also applied to this valve output. Only the communication objects can then be configured separately for the outputs. This setting should be selected, for example, if all the actuators behave identically and should only be activated by different group addresses (e.g. in office

blocks or in hotel rooms).

In the parameter setting "individually", each valve output possesses its own parameter pages in the ETS.

### 9.2.1 Channel configuration parameters

General -> Configuration

VO x (x = 1 ... 6) Use	Checkbox (yes / no)
Valve outputs that are not required can be activated or deactivated. If the following parameter "Parameterisation" is set to "like VO 1" for one of the following valve outputs, valve output 1 is activated automatically.	
VO x (x = 1 ... 6) Parameterisation	individually / like VO 1
To simplify the configuration, all the valve outputs can be assigned to the same parameters in the ETS and thus configured identically. This parameter stipulates whether a valve output of the device can be configured individually or whether the parameters of valve output 1 are to be applied. For valve output 1, the parameter is permanently set to "individually".	

## 9.3 Channel-independent functions

The heating actuator possesses a number of channel-independent functions that can be used for all valve outputs. To be able to use these functions, they must be enabled on the "General valve outputs" parameter page. The parameters of these channel-independent functions are set on parameter pages of their own.

In addition to the general enabling of the channel-independent functions, the individual valve outputs must also, in some cases, be assigned to the functions on the parameter pages "VOx - General -> Assignments".

### 9.3.1 Heat requirement

#### Heat requirement control

The heating actuator possesses heat requirement control. Here, the actuator continuously evaluates the command values of assigned outputs and makes general heat requirement information available as a 1-bit control value in the form of limiting value monitoring with hysteresis. Using a KNX switch actuator, this allows the energy-efficient activation of burner and boiler controllers with suitable control inputs (e.g. requirement-orientated switchover between the reduction and comfort setpoint in a central combi boiler).

A heat requirement is only signalled by the actuator via the object of the same name when at least one command value of the assigned outputs exceeds a limiting value with hysteresis defined in the ETS. A heat requirement signal is retracted when the limiting value is reached or undershot again (see figure 5). The telegram polarity of the heat requirement information can be configured.



- i** In addition, valve outputs, which receive preset command values via the data format "Switching (1-bit)" and "Switching (1-byte) with command value limiting value", influence the heat requirement control. In the case of "Switching (1-bit)", an "OFF" command value is interpreted as "0%" and an "ON" command value as "100%". In the case of "Switching (1-byte) with command value limiting value", the actuator evaluates the converted switching output signal in the same way ("OFF" is interpreted as "0%", "ON" is interpreted as "100%").
- i** With some functions and events, valve outputs, which are configured to the command value data formats "Switching (1-bit)" and "Switching (1-byte) with command value limiting value", are always activated via a constant command value through pulse width modulation (PWM), providing that command values not equal to 0% or 100% are to be set (after bus voltage return, after an ETS programming operation, during manual operation, with an active forced position and with active emergency operation). PWM keeps being executed until the named functions have been exited or, after the named events, no more lower-level functions are active and a new command value telegram is received via the bus, overriding the constant command value on the valve output.  
In this case, the constant command value set by the PWM is also included in the heat requirement control.
- i** After bus voltage return and an ETS programming operation, the actuator always first transmits the status "No heat requirement" without a delay. The actuator then updates the status to "Heat requirement", providing that the condition for this has been fulfilled and an optionally configured "Heat requirement ACTIVE" has elapsed.
- i** A valve output affected by a short-circuit / overload (valve completely closed on deenergised closed or completely opened on deenergised opened) does not influence the heat requirement control.

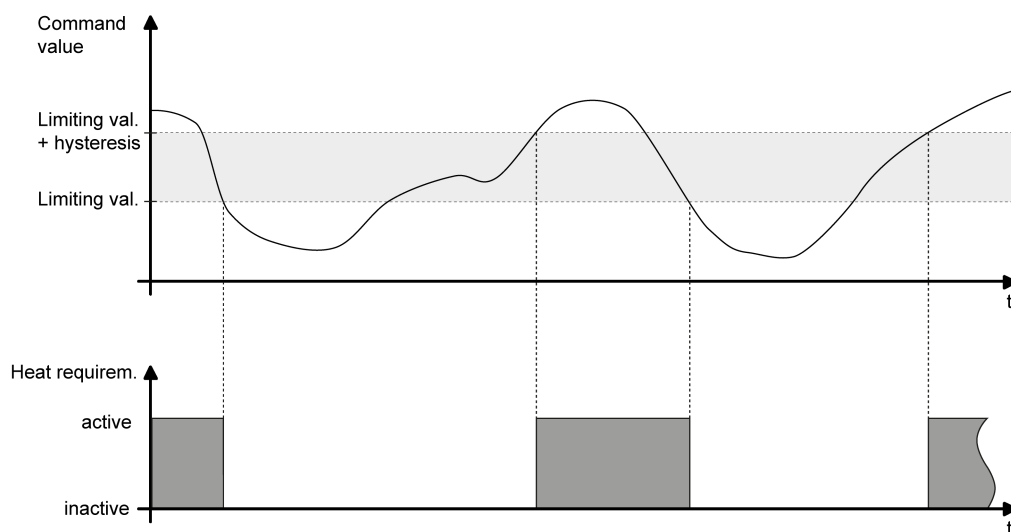

Image 5: Heat requirement information with sample command value characteristic



Optionally, the actuator can evaluate an external telegram for heat requirement information (e.g. from another heating actuator). This allows the cascading of multiple actuators with a heat requirement signal. The local heating actuator links the 1-bit telegram value of "External heat requirement" object with the internal state of its own heat requirement logically as OR and outputs the result of this link via the object "Heat requirement". The telegram polarity of the external object is fixed: "0" = Heat requirement INACTIVE, "1" = Heat requirement ACTIVE.

The actuator only outputs the telegram of an active heat requirement after determination when the delay time defined by the parameter "Delay heat requirement INACTIVE" has elapsed. No heat requirement request is transmitted if the actuator no longer determines a heat requirement within the preset time.

The actuator only retracts heat requirement information after determination when the delay time defined by the parameter "Delay heat requirement INACTIVE" has elapsed. The heat requirement information is not retracted if the actuator no longer determines a new heat requirement within the preset time.

### **Enabling and configuring the "Heat requirement" function**

The heat requirement function must first be enabled on the parameter page "General valve outputs" so that it can be used during actuator operation. The remaining parameters are set on the parameter page "Heat requirement". Additionally, the parameter pages of the individual valve outputs are relevant.

- Configure the parameter "Object polarity" to the required telegram polarity. In addition, define the minimum command value and hysteresis.  
Heat requirement control is activated. The heat requirement information becomes active according to the set telegram polarity, if at least one command value of the assigned valve outputs exceeds the configured limiting value plus hysteresis. The heat requirement becomes inactive when the limiting value is reached or undershot again.  
The valve outputs must be assigned to the heat requirement control individually on the parameter pages "VOx General -> Assignments" so that they are included in the requirement determination.
- Deactivate the "Heat requirement" checkbox.  
Heat requirement control is not available.

### **Enabling detection of an external heat requirement**

Optionally, the actuator can evaluate an external telegram for heat requirement information (e.g. from another heating actuator). This allows the cascading of multiple actuators with a heat requirement signal.

The object must be enabled for an external heat requirement to be recorded.

- Activate the checkbox "Detect external heat requirement via object".  
The "Heat requirement - External" object is enabled. The local heating actuator links the 1-bit telegram value of this object with the internal state of its own heat requirement logically as OR and outputs the result of this link via the object "Heat requirement - Status".

- Deactivate the checkbox "Detect external heat requirement via object".  
Detection of an external heat requirement is not possible. The actuator only determines the heat requirement information itself.
- i** Cyclical telegrams to the object "Heat requirement - External" with an identical telegram polarity (ON -> ON, OFF -> OFF) cause no reaction.
- i** After a device reset, there is no polling of the current status of the object "Heat requirement - External". Only when a bus telegram is received does the actuator take this status into account during evaluation of the heat requirement.

### 9.3.1.1 Heat requirement parameters

#### Enabling the heat requirement function

General valve outputs -> Enabled functions

Heat requirement	Checkbox (yes / no)
<p>The heating actuator can even evaluate the command values of its outputs and make general heat requirement available in the form of limiting value monitoring with hysteresis (1 bit, switching). Using a KNX switch actuator, this allows the energy-efficient activation of burner and boiler controllers with suitable control inputs (e.g. requirement-orientated switchover between the reduction and comfort setpoint in a central combi boiler).</p> <p>Here, the heat requirement control of the actuator can be enabled centrally. The valve outputs must be assigned to the heat requirement control individually on the parameter pages "VOx General -&gt; Assignments" so that they are included in the requirement determination.</p>	

#### Setting the heat requirement function

General valve outputs -> Heat requirement

Minimum command value	0 ... <b>5</b> ...100 %
<p>The actuator only signals a heat requirement when at least one command value of the assigned outputs exceeds the limiting value defined here plus the hysteresis (see next parameter). A heat requirement signal is retracted when the limiting value is reached or undershot again.</p> <p>This parameter is visible only if the heat requirement function is enabled.</p>	
Hysteresis of the minimum command value	1... <b>10</b> ...20 %
<p>This parameter specifies the hysteresis of the limiting value of the minimum command value of the heat requirement control. The actuator signals a heat requirement when a command value exceeds the defined limiting value plus the hysteresis defined here.</p> <p>This parameter is visible only if the heat requirement function is enabled.</p>	

Switch-on delay (heat requirement)	0...23 h 0...5...59 min 0...59 s
<p>The actuator only outputs the telegram of an active heat requirement after determination when the delay time defined here has elapsed. No heat requirement request is transmitted if the actuator no longer determines a heat requirement within the time preset here. This parameter is visible only if the heat requirement function is enabled.</p> <p>Definition of the hours, minutes and seconds of the delay time.</p>	
Switch-off delay (no heat requirement)	0...23 h 0...5...59 min 0...59 s
<p>The actuator only retracts heat requirement information after determination when the delay time defined here has elapsed. The heat requirement information is not retracted if the actuator no longer determines a new heat requirement within the preset time. This parameter is visible only if the heat requirement function is enabled.</p> <p>Definition of the hours, minutes and seconds of the delay time.</p>	
Object polarity	1 = heat requirement / 0 = no heat requirement 0 = heat requirement / 1 = no heat requirement
<p>This parameter defines the telegram polarity of the "Heat requirement - Status" object. It is visible only if the heat requirement function is enabled.</p>	
Detect external heat requirement via object?	Checkbox (yes / no)
<p>The actuator is able to evaluate an external heat requirement (e.g. from another heating actuator). The local heating actuator links the external telegram with the internal status of its own heat requirement logically as OR and outputs the result of this link via the object "Heat requirement".</p> <p>In the "yes" setting, this parameter will enable the object "Heat requirement - External". It is visible only if the heat requirement function is enabled.</p>	

### 9.3.1.2 Objects for heat requirement

Object no.	Function	Name	Type	DPT	Flag
10	Heat requirement - Status	General valve outputs - Output	1-bit	1,002	C, R, -, T, -

1-bit output object for the transmission of general heat requirement information to suitable burner and boiler controllers. A heat requirement is only signalled by the actuator when at least one command value of the assigned outputs exceeds a limiting value with hysteresis defined in the ETS. A heat requirement signal is retracted when the limiting value is reached or undershot again. In addition, the actuator can optionally evaluate an external telegram (object 11).

The telegram polarity can be configured. After bus voltage return and an ETS programming operation, the actuator always first transmits the status "No heat requirement" without a delay. The actuator then updates the status to "Heat requirement", providing that the condition for this has been fulfilled and an optionally configured "Heat requirement ACTIVE" has elapsed.

Object no.	Function	Name	Type	DPT	Flag
11	Heat requirement - External	General valve outputs - Input	1-bit	1,002	C, (R), W, -, -

1-bit input object for the cascading of multiple actuators with a heat requirement signal. The transmitting object of a heat requirement signal of another heating actuator can be connected to this object. The local heating actuator links the external telegram with the internal status of its own heat requirement logically as OR and outputs the result of this link via the object 10.

In this case, the telegram polarity is fixed: "0" = Heat requirement INACTIVE, "1" = Heat requirement ACTIVE.

Cyclical telegrams to this object with an identical telegram polarity (ON -> ON, OFF -> OFF) produce no reaction. After a device reset, there is no polling of the current status of this object. Only when a bus telegram is received does the actuator take this status into account during evaluation of the heat requirement.

### 9.3.2 Pump control

The heating actuator allows switching activation of the circulation pump of the heating or cooling circuit via a 1-bit KNX telegram. When using the pump controller, the pump is only switched on by the actuator via the "Pump control - Switch" object if at least one command value of the assigned outputs exceeds a limiting value with hysteresis defined in the ETS. The pump is switched off when the limiting value is reached or undershot again (see figure 6). This saves electrical energy, as the pump is only activated by sufficiently large, and thus effective, command values.

Optional cyclical anti-sticking protection prevents the sticking of the pump, if it has not been switched on by the command value evaluation for a longer period of time.

The telegram polarity of the pump control can be configured.

- i** In addition, valve outputs, which receive preset command values via the data format "Switching (1-bit)" and "Switching (1-byte) with command value limiting value", influence the pump control. In the case of "Switching (1-bit)", an "OFF"

command value is interpreted as "0%" and an "ON" command value as "100%". In the case of "Switching (1-byte) with command value limiting value", the actuator evaluates the converted switching output signal in the same way ("OFF" is interpreted as "0%", "ON" is interpreted as "100%").

- i** With some functions and events, valve outputs, which are configured to the command value data formats "Switching (1-bit)" and "Switching (1-byte) with command value limiting value", are always activated via a constant command value through pulse width modulation (PWM), providing that command values not equal to 0% or 100% are to be set (after bus voltage return, after an ETS programming operation, during manual operation, with an active forced position and with active emergency operation). PWM keeps being executed until the named functions have been exited or, after the named events, no more lower-level functions are active and a new command value telegram is received via the bus, overriding the constant command value on the valve output.  
In this case, the constant command value set by the PWM is also included in the pump control.
- i** After bus voltage return and an ETS programming operation, the actuator always first transmits the status "Pump OFF" without a delay. The actuator then updates the status to "Pump ON", providing that the condition for this has been fulfilled and an optionally configured "Pump delay ACTIVE" has elapsed.
- i** A valve output affected by a short-circuit / overload (valve completely closed on deenergised closed or completely opened on deenergised opened) does not influence the pump control.

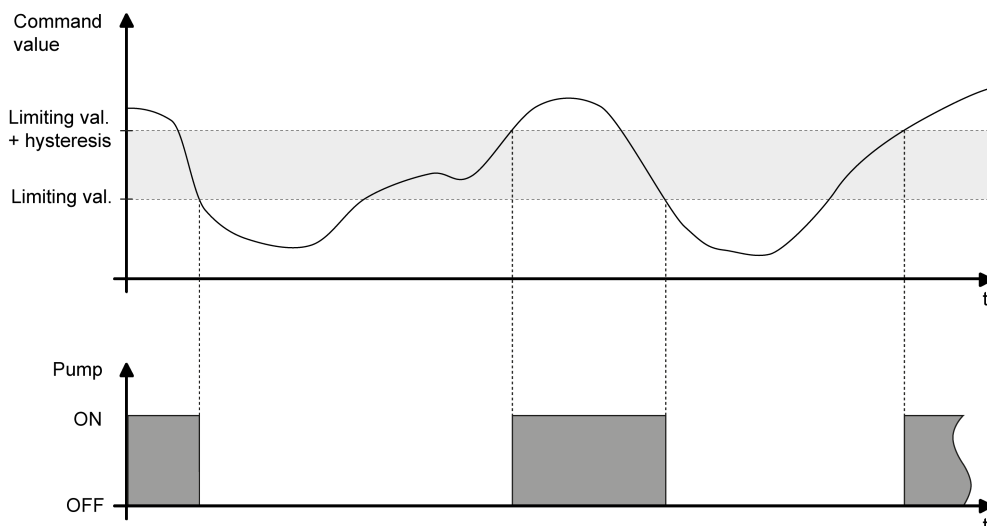

Image 6: Pump control with sample command value characteristic

Optionally, the actuator can evaluate an external pump control signal (e.g. from another heating actuator). This allows the cascading of multiple actuators with pump control. The local heating actuator links the 1-bit telegram value of the "Pump control - External" object with the internal state of the pump logically as OR and outputs the result of this link via the "Switch pump" object. The telegram polarity of the external object is fixed: "0" = Pump OFF, "1" = Pump ON.

The actuator only outputs the ON telegram to the pump after determination when the defined delay time has elapsed. The pump is not switched on when the actuator determines within the preset time that the pump must remain switched off, due to a limiting value plus hysteresis again being undershot.

The actuator only outputs the OFF telegram to the pump after determination when the defined delay time has elapsed. The pump is not switched on when the actuator determines within the preset time that the pump must remain switched off, due to a limiting value again being exceeded.

The delay times of the pump controller can be used as an example to match the running time of the pump to the reaction time of the actuated actuators. Thus, a pump should only switch on when the actuators actually open after electrical activation by the actuator (match pump ACTIVE delay with the dead time of the actuators). The same applies to the closing of the valve drives.

If pump control is enabled, optional cyclical anti-sticking protection can prevent the sticking of the pump, if it has not been switched on by the command value evaluation for a longer period of time (e.g. in the case of heating systems in the summer months). When anti-sticking protection is enabled, the parameter "Cyclical switching on" defines the weekly interval of the protection function. If the pump is not switched on at least once during the set time by the pump controller, then the actuator will execute anti-sticking protection, if necessary on a regular basis. The cycle time is reset and restarted on each actuation of the pump by the pump control. The cycle time is started for the first time after a device reset.

When anti-sticking protection is enabled, the parameter "Switch-on time" defines how long the pump should run for the cyclical protection function. The actuator then switches the pump on for the set time without interruption, assuming that anti-sticking protection must be executed.

### Enabling and configuring the pump control function

The "Pump control" function must first be enabled on the parameter page "General valve outputs" so that it can be used during actuator operation. The remaining parameters are set on the parameter page "Pump control". Additionally, the parameter pages of the individual valve outputs are relevant.

- Configure the parameter "Object polarity" to the required telegram polarity. In addition, define the minimum command value and hysteresis.

Pump control is activated. The pump is switched on according to the set telegram polarity if at least one command value of the assigned valve outputs exceeds the configured minimum command value plus hysteresis. The pump is switched off when the minimum command value is reached or undershot again.

The valve outputs must be assigned to the pump control individually on the parameter pages "VOx - General -> Assignments" so that they are included in the command value evaluation.

- Deactivate the parameter "Pump control".  
Pump control is not available.



## Enabling detection of an external pump control

Optionally, the actuator can evaluate an external telegram for pump control (e.g. from another heating actuator). This allows the cascading of multiple actuators with pump control.

The object must be enabled for an external pump control signal to be detected.

- Activate the checkbox "Detect external pump control via object".  
The "Pump control - External" object is enabled. The local heating actuator links the 1-bit telegram value of this object with the internal state of its own pump control logically as OR and outputs the result of this link via the "Switch pump" object.
- Deactivate the checkbox "Detect external pump control via object".  
Recording of an external pump control signal is not possible. The actuator only controls the pump itself.
- i** Cyclical telegrams to the "Pump control - External" object with an identical telegram polarity (ON -> ON, OFF -> OFF) cause no reaction.
- i** After a device reset, there is no polling of the current status of the "Pump control - External" object. Only when a bus telegram is received does the actuator take this status into account when controlling the pump.

## Configuring the anti-sticking protection of the pump controller

If pump control is enabled, optional cyclical anti-sticking protection can prevent the sticking of the pump, if it has not been switched on by the command value evaluation for a longer period of time. The anti-sticking protection must first be enabled on the parameter page "Pump control" so it is executed during actuator operation.

- Activate the checkbox. In addition, define the interval of the protection function in the parameter "Cyclical switching on". Configure the parameter "Switch-on time" to the required length of the pump run.  
Anti-sticking protection is activated. If the pump is not switched on at least once during the set time by the pump controller, then the actuator will execute anti-sticking protection, if necessary on a regular basis. The actuator then switches the pump on for the preset switch-on time.
- Deactivate checkbox.  
Anti-sticking protection is deactivated.
- i** Once started, the anti-sticking protection always runs through to the end. It cannot be cancelled prematurely through the reception of new command values and the resulting restart of the cycle time.

### 9.3.2.1 Pump control parameters

#### Enabling the pump control function

General valve outputs -> Enabled functions

Pump control	Checkbox (yes / no)
<p>The heating actuator allows switching activation of the circulation pump of a heating or cooling circuit via a 1-bit KNX telegram.</p> <p>Here, the pump control of the actuator can be enabled centrally ("yes" setting). The valve outputs must be assigned to the pump control individually on the parameter pages "Ax - Assignments", so that they are included in the control.</p>	

#### Setting the pump control function

General valve outputs -> Pump control

Minimum command value	0...100 %
<p>The actuator only switches the pump on when at least one command value of the assigned outputs exceeds the defined limiting value plus the hysteresis defined here (see next parameter). The pump is switched off when the limiting value is reached or undershot again.</p> <p>This parameter is visible only if the pump control is enabled.</p>	

Hysteresis of the minimum command value	1...20 %
<p>This parameter specifies the hysteresis of the limiting value of the minimum command value of the pump control. The actuator only switches the pump on when a command value exceeds the defined limiting value plus the hysteresis defined here.</p> <p>This parameter is visible only if the pump control is enabled.</p>	

#### Anti-sticking protection

Activate	Checkbox (yes / no)
<p>If pump control is enabled, optional cyclical anti-sticking protection can prevent the sticking of the pump, if it has not been switched on by the command value evaluation for a longer period of time. In the "Yes" setting, this parameter enables cyclical anti-sticking protection.</p>	

Cyclical switching on	1...26 weeks
<p>When anti-sticking protection is enabled, the length of protection function is defined here. If the pump is not switched on by the pump controller at least once during the time set here, then the actuator will execute anti-sticking protection, if necessary on a regular basis.</p>	



Switch-on time	1...5...15 minutes
When anti-sticking protection is enabled, the length of pump running for the cyclical protection function must be preset here. The actuator then switches the pump on for the time set here without interruption, assuming that anti-sticking protection must be executed.	

### Delay times

Switch-on delay (pump requirement)	0...59 min 0...10...59 s
The actuator only outputs the ON telegram to the pump after determination when the delay time defined here has elapsed. The pump is not switched on when the actuator determines within the time preset here that the pump must remain switched off, due to a limiting value plus hysteresis again being undershot. This parameter is visible only if the pump control is enabled. Definition of the minutes and seconds of the delay time.	

Switch-off delay (no pump requirement)	0...23 h 0...10...59 min 0...59 s
The actuator only outputs the OFF telegram to the pump after determination when the delay time defined here has elapsed. The pump is not switched on when the actuator determines within the time preset here that the pump must remain switched off, due to a limiting value again being exceeded. This parameter is visible only if the pump control is enabled. Definition of the hours, minutes and seconds of the delay time.	

Object polarity	0 = Switch off pump / 1 = Switch on pump 1 = Switch off pump / 0 = Switch on pump
This parameter defines the telegram polarity of the "Pump control" object. It is visible only if the pump control is enabled.	

Detect external pump control via object	Checkbox (yes / no)
The actuator is able to evaluate an external pump control signal (e.g. from another heating actuator). The local heating actuator links the external telegram with the internal status of the pump logically as OR and outputs the result of this link via the object "Switch pump". This parameter will enable the object "External pump control" in the "Yes" setting. It is visible only if the pump control is enabled.	

### 9.3.2.2 Objects for pump control

Function: Pump control

Object no.	Function	Name	Type	DPT	Flag
6	Pump control - Switch	General valve outputs - Output	1-bit	1,001	C, R, -, T, -

1-bit output object for direct activation of a circulation pump of the heating or cooling system. The pump is only switched on by the actuator when at least one command value of the assigned outputs exceeds a limiting value with hysteresis defined in the ETS. The pump is switched off when the limiting value is reached or undershot again. In addition, the actuator can optionally evaluate an external telegram (object 7).

The telegram polarity can be configured. After bus voltage return and an ETS programming operation, the actuator always first transmits the status "Pump OFF" without a delay. The actuator then updates the status to "Pump ON", providing that the condition for this has been fulfilled and an optionally configured "Pump delay ACTIVE" has elapsed.

Function: Pump control

Object no.	Function	Name	Type	DPT	Flag
7	Pump control - External	General valve outputs - Input	1-bit	1,001	C, (R), W, -, -

1-bit input object for the cascading of multiple actuators with pump control. The transmitting operation for the pump control of another heating actuator can be connected to this object. The local heating actuator links the external telegram with the internal status of the pump logically as OR and outputs the result of this link via the object 6.

In this case, the telegram polarity is fixed: "0" = Pump OFF, "1" = Pump ON. Cyclical telegrams to this object with an identical telegram polarity (ON -> ON, OFF -> OFF) produce no reaction. After a device reset, there is no polling of the current status of this object. Only when a bus telegram is received does the actuator take this status into account when activating the pump.

### 9.3.3 Largest command value

#### Largest command value

Through evaluation and determination of the largest command value in the heating or cooling system, the actuator allows influencing of the energy consumption of a housing or commercial building. The information on the largest active 1-byte command value can be made available to suitable calorific furnaces with integrated KNX controller directly via a KNX telegram, for example, to determine the optimum flow temperature. If the function is enabled, the heating actuator evaluates all the active 1-byte command values of the valve outputs and transmits the externally received largest command value if there is a change by the interval preset in the ETS or cyclically via the object "Largest command value - Status".

- i** In the case of valve outputs configured in the ETS to the command value data formats "Switching (1-bit)" or "Constant (1-byte) with command value limiting value", there is no evaluation of the command values preset via the bus. Exception: It may also occur with such command value outputs that a constant command value is active (after bus voltage return, after an ETS programming operation, during manual operation, with an active forced position and with active emergency operation). In this case, this constant command value is also included in the calculation of the largest command value until the named functions with a higher priority are exited or a new command value telegram is received via the bus, overriding the constant command value at the valve output.
- i** After bus voltage return and an ETS programming operation, the actuator transmits the current value of the largest command value without a delay, providing that automatic transmission on change is configured. After a full device reset, the actuator does not transmit automatically, when all the command values are set to 0%. After a device reset, the actuator immediately starts the time for cyclical transmission (if configured), so that the object value effective after the reset is transmitted cyclically.
- i** A valve output affected by a short-circuit / overload (valve completely closed on deenergised closed or completely opened on deenergised opened) does not influence the evaluation of the largest command value.

Optionally, the actuator can evaluate an external telegram for the largest command value (e.g. from another heating actuator). This allows the cascading of multiple actuators with a command value signal. The local heating actuator compares the 1-byte telegram value of the object "External largest command value" with its own largest command value and outputs the largest value via the object "Largest command value".

### Enabling the "Largest command value" function

The "Largest command value" function must first be enabled on the "General valve outputs" parameter page, so that it can be used during actuator operation. The remaining parameters are set on the parameter page "Largest command value". Additionally, the parameter pages of the individual valve outputs are relevant.

- Set the parameter "Transmit" to "on change" and/or "cyclical" and set the corresponding criteria.  
The "Largest command value" function is activated. The actuator always compares the 1-byte command values of assigned valve outputs and signals the largest command value via the communication object of the same name.
- Deactivate the checkbox "Largest command value".  
The function for transferring the largest command value is not available.

### Enabling recording of an external largest command value

Optionally, the actuator can evaluate an external telegram for the largest command value (e.g. from another heating actuator). This allows the cascading of multiple actuators with a command value signal.

The object must be enabled for an external largest command value to be recorded.

- Activate the checkbox "Record external largest command value via object".  
The "Largest command value - External" object is enabled. The local heating actuator compares the 1-byte telegram value of this object with its own largest command value and outputs the largest value via the object "Largest command value".
  - Deactivate the checkbox "Record external largest command value via object".  
Recording of an external largest command value is not possible. The actuator independently determines the largest command value of the valve outputs assigned to it.
- i** Cyclical telegrams to the "Largest command value - External" object with the same telegram value cause no reaction.
- i** After a device reset, there is no polling of the current status of the "Largest command value - External" object. Only when a bus telegram is received does the actuator take this value into account during evaluation of the largest command value.

#### 9.3.3.1 Largest command value parameters

##### Enabling the "Largest command value" function

General valve outputs -> Enabled functions

Largest command value	Checkbox (yes / no)
<p>The actuator can determine the largest constant command value and forward it to another bus device (e.g. suitable calorific furnaces with integrated KNX control or visualisation). In the "Yes" setting, the heating actuator evaluates all the active 1-byte command values of the valve outputs and, optionally, the externally received largest command value (object "External largest command value") and transmits the largest command value via the "Largest command value" object.</p> <p>In the case of valve outputs configured in the ETS to the command value data formats "Switching (1-bit)" or "Constant (1-byte) with command value limiting value", there is no evaluation of the command values preset via the bus. Exception: It may also occur with such command value outputs that a constant command value is active (e.g. after bus/mains voltage return or a forced position and emergency operation or manual operation). In this case, this constant command value is also included in the calculation of the largest command value until the named functions with a higher priority are exited or a new command value telegram is received via the bus, overriding the constant command value at the valve output.</p>	

## Setting the "Largest command value" function

General valve outputs -> Largest command value

Transmit	<b>on change</b> cyclical on change and cyclical
<p>The largest command value determined by the heating actuator is actively transmitted to the bus. This parameter decides when a telegram is transmitted via the "Largest command value" object.</p> <p>This parameter is visible only if the "Largest command value" function is enabled.</p> <p>On change: A telegram is only transmitted when the largest command value changes.</p> <p>Cyclical: The actuator only transmits the "Largest command value - Status" telegram cyclically. The cycle time is defined globally for all feedback on the parameter page "General".</p> <p>On change and cyclical: The actuator transmits the "Largest command value - Status" telegram when the object value changes and also cyclically.</p>	
Transmit on change by	0.3 %, 0.5 %, 1...3...20 %
<p>Here, the change interval of the largest command value for automatic transmission is defined. The actuator only transmits a new telegram value when the largest command value has changed by the interval preset here since the last transmission operation.</p> <p>This parameter is visible only if the "Largest command value" function is enabled.</p>	
Detect external largest command value via object	Checkbox (yes / no)
<p>The actuator is able to evaluate an external largest command value (e.g. from another heating actuator). The local heating actuator monitors the external telegram with its own active constant command values and outputs the largest of all command values via the object "Largest control value - Status".</p> <p>This parameter will enable the object "Largest command value - External" in the "yes" setting. It is only available when the "Largest command value" function is enabled.</p>	

### 9.3.3.2 Objects for largest command value

Function: Evaluation of the largest command value

Object no.	Function	Name	Type	DPT	Flag
8	Largest command value - Status	General valve outputs - Output	1 bytes	5,001	C, R, -, T, -

1-byte output object for transmission of the largest constant command value of the heating actuator to another bus device (e.g. suitable calorific furnaces with integrated KNX controller or visualisation). The heating actuator evaluates all the active 1-byte command values of the valve outputs and, optionally, the externally received largest command value (object 9) and transmits the largest command value via this object.

In the case of valve outputs configured in the ETS to the command value data formats "Switching (1-bit)" or "Constant (1-byte) with command value limiting value", there is no evaluation of the command values preset via the bus. Exception: It may also occur with such command value outputs that a constant command value is active (e.g. after bus/mains voltage return or a forced position and emergency operation or manual operation). In this case, this constant command value is also included in the calculation of the largest command value until the named functions with a higher priority are exited or a new command value telegram is received via the bus, overriding the constant command value at the valve output.

After bus voltage return and an ETS programming operation, the actuator transmits the current value of the largest command value without a delay, providing that automatic transmission on change is configured. After a full device reset, the actuator does not transmit automatically, when all the command values are set to 0%.

After a device reset, the actuator immediately starts the time for cyclical transmission (if configured), so that the object value effective after the reset is transmitted cyclically.

Function: Evaluation of the largest command value

Object no.	Function	Name	Type	DPT	Flag
9	Largest command value - External	General valve outputs - Input	1 bytes	5,001	C, (R), W, -, -

1-bit input object for the cascading of multiple actuators with evaluation of the largest constant command value. The transmitting object of a largest command value of another heating actuator can be connected to this object. The local heating actuator monitors the external telegram with its own active constant command values and outputs the largest of all command values via object 8.

Cyclical telegrams to this object with the same value cause no reaction. After a device reset, there is no polling of the current status of this object. Only when a bus telegram is received does the actuator take this status into account during evaluation.

### 9.3.4 Summer / winter mode switchover

The actuator possesses a summer / winter switchover. Depending on the season, this allows the setting of different command value setpoints for a valve output for emergency operation or forced position. Summer or winter mode is directly preset by the 1-bit communication object "Summer / winter switchover". The telegram polarity can be configured in the ETS.



The "Summer" or "Winter" state preset via the object is stored internally in the device and is restored after a device reset. In the ETS, it is possible to configure whether, after an ETS programming operation, the saved value is restored or, alternatively, if a defined operation (summer or winter) is activated.

It is also possible to switch the operating mode during active emergency operation (if called by command value monitoring) or during an active forced position (if activated via the object). In this case, the value belonging to the operating mode is activated immediately after the switchover. If the value for emergency operation or the forced position is polled on a bus/mains voltage return or after an ETS programming operation, the command values do not change when the operating mode is switched over.

### **Enabling summer / winter switchover**

The summer / winter switchover must first be enabled on the "General valve outputs" parameter page, so that it is possible to switch between summer and winter mode during actuator operation. The remaining parameters are set on the parameter page "Summer / winter mode switchover". Additionally, the parameter pages of the individual valve outputs are relevant.

- Configure the parameter "Object polarity" to the required telegram polarity.  
The summer / winter switchover is enabled. The communication object "Summer / winter switchover" becomes visible in the ETS. On the parameter pages of the individual valve outputs, summer and winter command values can be configured for emergency operation and for a forced position.
- Deactivate the checkbox "Summer / winter mode" on the parameter page "Valve outputs -> General valve outputs".  
The summer / winter switchover is not available. For the valve outputs, only one command value can be configured separately for emergency operation or a forced position.

### **Defining the behaviour after of the summer / winter switchover during an ETS programming operation**

The "Summer" or "Winter" state preset via the object "Summer / winter switchover" is stored internally in the device and is restored after bus voltage return. The parameter "After ETS programming" on the parameter page "Summer / winter mode switchover" also defines which operating mode is active after ETS commissioning.

- Set the parameter to "Summer mode".  
In this setting, the actuator activates summer operation after an ETS programming operation. This overwrites the value saved internally in the device.
- Set the parameter to "winter mode".  
In this setting, the actuator activates winter mode after an ETS programming operation. This overwrites the value saved internally in the device.
- Set the parameter to "No change (saved operating mode)".

In this configuration, the actuator activates the most recently saved operating mode.

- i** The operating mode tracked after bus voltage return or preset after an ETS programming operation is not tracked in the communication object "Summer / winter switchover" by the actuator.

### 9.3.4.1 Summer / winter switchover parameters

#### Enabling the summer / winter mode function

General valve outputs -> Enabled functions

Summer / winter mode	Checkbox (yes / no)
<p>The device possesses a summer / winter switchover. Depending on the season, this allows the setting of different command value setpoints for the valve output for emergency operation or forced position.</p> <p>Activated: The summer / winter switchover is enabled. The communication object "Summer / winter switchover" becomes visible. Summer and winter command values can be configured for emergency operation and a forced position for the valve output.</p> <p>Deactivated: The summer / winter switchover is not available. For the valve output, only one command value can be configured separately for emergency operation or a forced position.</p>	

#### Setting the summer / winter mode function

General valve outputs -> Summer / winter mode

Object polarity	<b>1 = Winter / 0 = Summer</b> 1 = Summer / 0 = Winter
This parameter sets the telegram polarity of the "Summer / winter mode" object.	
After ETS programming operation	Summer mode Winter mode <b>no change (saved operating mode)</b>
<p>The "Summer" or "Winter" state preset via the object "Summer / winter mode" is stored internally in the device and is restored after a device reset (voltage return). The parameter "After ETS programming operation" defines which operating mode is active after ETS commissioning.</p> <p>Summer operation: In this setting, the device activates summer operation after an ETS programming operation. This overwrites the value saved internally in the device.</p> <p>Winter operation: In this setting, the device activates winter operation after an ETS programming operation. This overwrites the value saved internally in the device.</p> <p>no change (saved operating mode): In this configuration, the device activates the most recently saved operating mode.</p>	



### 9.3.4.2 Objects for summer / winter switchover

Function toggling of the Summer / Winter operating mode

Object no.	Function	Name	Type	DPT	Flag
12	Summer / winter mode	General valve outputs - Input	1-bit	1,002	C, (R), W, -, -

1-bit input object to switch over between summer and winter mode. The telegram polarity can be configured. The status is stored internally in the device if there is a bus or mains voltage failure and is restored after a device reset.  
Cyclical telegrams to this object with an identical telegram polarity (ON -> ON, OFF -> OFF) produce no reaction.

### 9.3.5 Service mode

Service mode allows the bus-controlled locking of all or some valve outputs for maintenance or installation purposes. If service mode is active, actuators can be moved to a defined position (completely open or closed) and locked against activation by command value telegrams. Both service mode and the locking state are preset by a 2-bit forced operation telegram, according to KNX DPT 2.001.

The first bit (bit 0) of the object "Service mode - Activate / deactivate input" directly specifies the locking state. The second bit (bit 1) of the object activates or deactivates service mode. The locking state in the telegram is only evaluated by the actuator, when bit 1 plans for active service mode. Otherwise, bit 0 is ignored.

- i** The valves activated by service mode open or close completely and statically. No pulse width modulation is executed. The configured valve direction of action is taken into account in the electrical activation of the outputs.

Bit 1	Bit 0	Function
0	x	Service mode not active -> normal control according to priority rule
0	x	Service mode not active -> normal control according to priority rule
1	0	Service mode active: Close valves
1	1	Service mode active: Open valves

Bit coding of service mode

Service mode influences the status signals of the affected valve outputs. Depending on the configured command value data format, the following command values are assumed when service mode is active...

- Switching (1-bit):  
Valve closed = OFF  
Valve opened = ON
- Constant (1-byte) with pulse width modulation (PWM):  
Valve closed = 0%  
Valve opened = 100%

- Constant (1-byte) with command value limiting value:  
Valve closed = OFF  
Valve opened = ON

**i** The command value preset by an active service mode is also included in the determination of heat requirements and the largest command value. In addition, service mode has an influence on pump control.

The behaviour of the assigned valve outputs at the end of service mode can be configured. In addition, a 1-bit status object can signal when service mode is active or not.

**i** Updates of the object from "Service mode active" to "Service mode active" while maintaining the forced valve status or from "Service mode inactive" to "Service mode inactive" produce no change in the behaviour of the value outputs. However, the status telegram of the service mode is retransmitted on each update.

**i** Valve outputs locked by service mode can still be activated in manual operation. At the end of a manual operation, the actuator executes the service reaction for the appropriate valve outputs once again if service mode is still activated at this time.

### Enabling service mode

Service mode must first be enabled on the "General valve outputs" parameter page, so that it can be activated and deactivated via the KNX during actuator operation.

- Activate the checkbox "Service mode".  
Service mode is enabled. The communication objects "Valve outputs service mode - Activate / Deactivate" und "Valve outputs service mode - Status" become visible. Valve outputs can be assigned on the parameter pages "VOx - General -> Assignments".
- Deactivate the checkbox "Service mode".  
Service mode is not available. No valve outputs can be assigned to service mode in the ETS.

### Assigning outputs to service mode

For a valve output to be influenced by service mode, an assignment must take place. On the parameter pages "VOx - General -> Assignments", it is possible to define the assignment to service mode separately for each valve output.

- Activate the checkbox "Service mode".  
The appropriate valve output is assigned to service mode. It is locked according to the object value when service mode is active.
- Deactivate the checkbox "Service mode".  
The valve output is not assigned to service mode. Activation and deactivation of the service function does not influence the output.

- i** Assignments can only be made on the parameter pages "VOx - General -> Assignments" if service mode is enabled on the "General valve outputs" parameter page.

### Defining the behaviour at the end of service mode

When service mode is deactivated, the assigned valve outputs are enabled again. Activation of these outputs using command value telegrams or other functions with a lower priority is then possible. The parameter "Behaviour at the end" on the parameter page "General valve outputs - Service mode" specifies the state to which the affected valve outputs are set after enabling.

- i** At the end of service mode, the actuator only then executes the configured behaviour if, at the time of enabling, no function with a lower priority is active. Should such a function be active (e.g. forced position), then the actuator will execute it.
- Set the parameter to "No change".  
In this setting, assigned valve outputs show no reaction at the end of service mode. They remain in the most recently set state, until a new command value presetting is implemented.
  - Set the parameter to "Close output completely".  
In this setting, all the assigned valve outputs close completely. Here too, the actuators remain in this state until a new command value presetting is implemented.
  - Set the parameter to "Open output completely".  
In this setting, all the assigned valve outputs open completely. The actuators remain in this state until a new command value presetting is implemented.
  - Set the parameter to "Track state".  
In this configuration, the valve state received during the service function or preset by the function is tracked at the end of service mode.

### Status function of service mode

An active service mode can optionally be displayed by a 1-bit status object. A telegram with the value "1" displays an active service mode. A telegram with the value "0" displays a deactivated service function.

As soon as service mode is enabled in the ETS, the status communication object is also available.

- i** Updates of the 2-bit input object from "Service mode active" to "Service mode active" or from "Service mode inactive" to "Service mode inactive" always causes retransmission of the status telegram.
- i** The object value of the status function is not transmitted automatically to the bus after a device reset (ETS programming operation, voltage return).

### 9.3.5.1 Service mode parameters

The following parameters are parameterised on the parameter page "General -> General - Valve outputs -> Enabled functions".

Service mode	Checkbox (yes / no)
Service mode allows the bus-controlled locking of the valve output in case of maintenance or installation. If service mode is active, actuators can be moved to a defined position (completely open or closed) and locked against activation by command value telegrams.	
Active: Service mode is enabled. The communication object "Service mode - Deactivate / activate input" becomes visible.	
Inactive: Service mode is not available.	

The following parameters are parameterised on the parameter page "General -> General - Valve outputs -> Service mode".

Behaviour at the end	no change Close output completely Open output completely Track state
This parameter specifies the state which the valve output goes into on when service mode is deactivated.	
Restore last status after bus voltage return	Checkbox (yes / no)
This parameter defines whether the previous service mode state is automatically restored after bus voltage return.	

### 9.3.5.2 Objects for service mode

Function: Activate / deactivate service mode

Object no.	Function	Name	Type	DPT	Flag
16	Service mode - Activate / deactivate	General valve outputs - Input	2-bit	2,001	C, (R), W, -, -
2-bit input object for activating and deactivating service mode. With the value "1", bit 1 of the telegram activates service mode. The assigned valve outputs are then locked in the status preset by bit 0 ("0" = Closed / "1" = Opened). The configured valve direction of action is taken into account. The value "0" in bit 1 deactivates service mode again.					
0x = Service mode deactivated					
10 = Service mode activated, valves closed					
11 = Service mode activated, valves opened					

Function: Service mode status

Object no.	Function	Name	Type	DPT	Flag
17	Service mode status	Service mode - output	1-bit	1,002	C, R, -, T, -
<p>1-bit output object for status signalling of whether the service mode is active or not. In this case, the telegram polarity is fixed: "0" = Service mode inactive, "1" = Service mode active.</p> <p>The object value is not transmitted automatically after a device reset (ETS programming operation, bus voltage return).</p>					

### 9.3.6 Failure of the valve operating voltage

To activate the valve drives, the actuator requires a separate operating voltage supply (AC 24 V or AC 230 V). Valve outputs can only be electrically activated when the valve operating voltage supply is switched on. If there is no valve voltage supply, then the drives will move to their idle position (deenergised opened / closed). To prevent a failure of the valve voltage supply at the actuator from going undetected, a 1-bit fault signal can be optionally transmitted to the bus via the object "Failure of operating voltage". The telegram polarity of this fault signal can be configured. If the actuator detects that there is no valve voltage, then the failure telegram ("Voltage failed") is transmitted immediately. Only when the valve voltage has been reconnected will the actuator retract the fault signal ("Voltage available").

A valve which has been completely opened (deenergised opened) by the failure of the valve operating voltage is not include in the determination of heat requirement or the "Largest command value" and has no influence on the pump control.

#### Enabling the signal "Operating voltage status"

If the valve operating voltage failure signal is to be used, the parameter "Status" on the parameter page "Valve outputs - General valve outputs" must first be activated. This enables the parameter page "Status". The status of the operating voltage can be activated there.

- Activate the checkbox. Configure the parameter "Object polarity" to the required telegram polarity.  
The failure signal is enabled. The actuator actively transmits a "Voltage failed" telegram when it detects a failed or switched-off valve voltage supply, when the bus voltage supply is still switched on. The actuator transmits a "Voltage available" telegram as soon as the valve voltage supply is available again and the bus voltage is switched on.
- Deactivate the checkbox.  
The failure signal is not available.

#### Setting the behaviour of the failure signal on bus voltage return

The object for the transmission of a failure of the valve operating voltage can actively transmit the feedback information after a bus voltage return and an ETS programming operation. As an option, it is possible to configure in the ETS whether active

telegram transmission should take place after a device reset or not.

After a device reset, the failure signal of the valve operating voltage can be optionally time-delayed with the delay being set globally for all feedback together on the parameter page "General - Valve outputs".

- Set the parameter "Delay after bus voltage return" to "yes".  
The feedback "Failure of operating voltage" will be transmitted with a delay after bus voltage return or after an ETS programming operation. No feedback is transmitted during a running time delay, even if a valve state changes.
- Set the parameter "Delay after bus voltage return" to "no".  
The feedback "Failure of operating voltage" will be transmitted immediately after bus voltage return or after an ETS programming operation.

### Setting cyclical transmission of the failure signal

The signal telegram "Failure of operating voltage" can be transmitted cyclically, should the actuator determine a failed valve operating voltage. If the valve operating voltage exists, then transmission is generally not cyclical.

- Set the parameter "Cyclical transmission" to "yes".  
The actuator repeats the signal telegram "Failure of operating voltage", should a failed valve operating voltage have been determined. The cycle time is defined for all feedback on the parameter page "General - Valve outputs".
  - Set the parameter "Cyclical transmission" to "no".  
The signal telegram "Failure of operating voltage" is generally not repeated cyclically.
- i** During a delay after bus/mains voltage return or an ETS programming operation, transmission is not cyclical.

### 9.3.6.1 Valve voltage status parameters

Activate	no / yes
The actuator monitors the voltage supply of the valve drives. On a failure, a 1-bit signal telegram can be transmitted. This parameter enables the feedback function.	
Object polarity	0 = Voltage failed / 1 = Voltage present 1 = Voltage failed / 1 = Voltage present
This parameter sets the telegram polarity of the signal telegram for the transmission of a failure of the valve operating voltage. It is only visible with the status message activated.	

Transmit after bus voltage return	no / yes
<p>The object for the transmission of a failure of the valve operating voltage can actively transmit the feedback information after a bus voltage return and an ETS programming operation. This parameter specifies whether active telegram transmission should take place after a device reset or not. It is only visible with the status message activated.</p>	
Delay after bus voltage return	no / yes
<p>The feedback "Failure of operating voltage" will be transmitted to the bus after bus voltage return or after an ETS programming operation. In these cases, the feedback can be time-delayed with the time delay being preset globally for all device feedback together on the "General" parameter page. This parameter is only visible if the signal function is enabled and transmission after bus voltage return is enabled.</p> <p>no: The feedback "Failure of operating voltage" is transmitted immediately after bus / mains voltage return or after an ETS programming operation.</p> <p>yes: The feedback "Failure of operating voltage" will be transmitted with a delay after bus voltage return or after an ETS programming operation. No feedback is transmitted during a running time delay, even if the state changes.</p>	
Cyclical transmission	no / yes
<p>The signal telegram "Failure of operating voltage" can be transmitted cyclically, should the actuator determine a failed valve operating voltage. This parameter specifies whether cyclical telegram transmission should take place or not. If the valve operating voltage exists, then transmission is generally not cyclical. This parameter is only visible with the status message activated.</p>	

### 9.3.6.2 Objects for valve voltage status

Function: monitoring of the valve operating voltage

Object no.	Function	Name	Type	DPT	Flag
5	Failure of operating voltage - Status	General valve outputs - Output	1-bit	1,005	C, R, -, T, -
<p>1-bit output object to signal a failure of the operating voltage (AC 24 V or AC 230 V) of the valve outputs. The telegram polarity can be configured.</p>					

## 9.4 Valve output - General

### 9.4.1 Name

Optional names can be assigned for each valve output. The names should clarify the use of the output (e.g. "living room floor"). The names are only used in the ETS in the text of the parameter pages and communication objects.



## 9.4.2 Data formats for command values

The heating actuator receives 1-bit or 1-byte command value telegrams, transmitted, for example, by KNX room temperature controllers. Usually, the room temperature controller determines the room temperature and generates the command value telegrams using a control algorithm. The actuator controls its valve outputs either in switching form or with a PWM signal, according to the data format of the command values and the configuration in the ETS. The cycle time for constant PWM output signals can be configured separately for each valve output of the heating actuator. This allows individual adaptation to different actuator types.

**i** It should be noted that the valve outputs do not carry out temperature control themselves. The actuator converts received command value telegrams or command value presets (e.g. from the internal room temperature controllers of the heating actuator) into constant or switching output signals using device functions.

The "Data format" parameter, which is available separately for each valve output on the parameter pages "VOx - General", specifies the input format of the command value objects.

### Data format of the command value input "Switching (1-bit)"

In the case of a 1-bit command value, the telegram received via the command value object is forwarded directly to the appropriate output of the actuator, taking the configured valve direction of action into account. This means that, if an "ON" telegram is received, the valve is completely opened. The output is then energised for energised closed valves and the output is deenergised for energised opened valve drives. The valve is closed completely when an "OFF" telegram is received. The valve output is then not energised for deenergised closed valves and energised for deenergised opened valve drives.

In the functions and events listed below, valve outputs configured to the command value data formats "Switching (1-bit)" are always activated by a constant command value with pulse width modulation (PWM), provided that command values not equal to 0% or 100% are to be set...

- Active forced position,
- Active emergency operation,
- After bus voltage return,
- After an ETS programming operation,
- During a manual operation.

PWM keeps being executed until the named functions have been exited or, after the named events, no more lower-level functions are active and a new command value telegram is received via the bus, overriding the constant command value on the valve output.

**i** In the named cases, the constant command value is also included in the calculation of the largest command value and that of the heat requirement and pump control (optional functions).



- i** Valve outputs, which receive preset command values via the data format "Switching (1-bit)", influence the heat requirement and pump control. Here, an "OFF" command value is interpreted as "0%" and an "ON" command value as "100%".

### Data format of the command value input "Constant (1-byte) and activation with pulse width modulation (PWM)"

Command values corresponding to the data format "Constant (1-byte)" are implemented by the actuator with an equivalent pulse-width-modulated switch signal at the valve outputs. Taking the cycle time settable in the actuator for each output into account, the average output signal resulting from this modulation is a measure of the centred valve position of the control valve and thus a reference for the set room temperature. A shift of the mean value, and thus a change in the heating capacity, can be obtained by changing the duty factor of the switch-on and switch-off pulses of the output signal (see figure 7). The duty factor is adapted constantly by the actuator, depending on the command value received (normal operation) or by active device functions (e.g. manual operation, forced position, emergency operation).

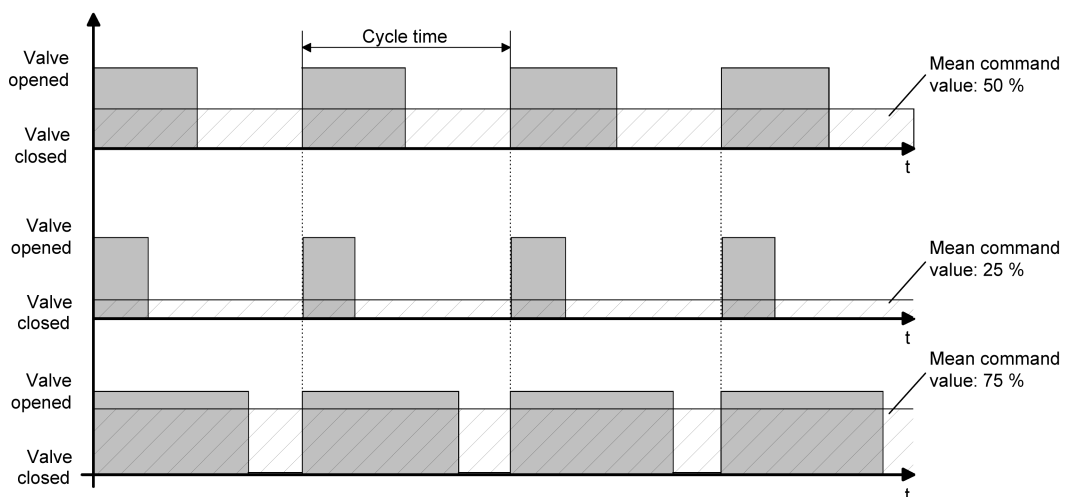

Image 7: Resulting mean value through variable duty factor with pulse width modulation

In accordance with the configured valve direction of action, the appropriate outputs are either energised or deenergised, depending on the valve position to be approached. In so doing, the duty factor is inverted automatically for a deenergised opened drive. Thus, depending on the valve type used, there is no unintended mean value shift.

Example: Command value: 60% ->

- Duty factor, deenergised closed: 60% ON, 40% OFF,
- Duty factor, deenergised opened: 40% ON, 60% OFF.

Example: Command value: 100% ->

- Duty factor, deenergised closed: Permanently ON,
- Duty factor, deenergised opened: Permanently OFF.

Often, control circuits are subject to non-constant changes in the setpoint presetting (e.g. frost protection, night operation, etc.) or short-time interference (e.g. measured value deviations due to brief opening of windows or doors near the sensor). For the setting of the scanning ratio of the required command value to take place as quickly and correctly in these cases, even with a longer set cycle time, without any negative impact on the reaction time of the control section, the actuator uses a special method for continuous command value adjustment.

The following cases are taken into account...

– Case 1

Command value change, e.g. from 80% to 30%, during the opening phase of the valve (see figure 8).

Before the reception of the new command value (30%), the old setpoint (80%) was active. The new command value is received during the opening phase of the valve. At this point, the actuator detects that it is still possible to shorten the opening phase, so that it corresponds to the new command value (30%). The cycle time is not affected by this operation.

The new duty factor is set immediately after the reception of the new command value.

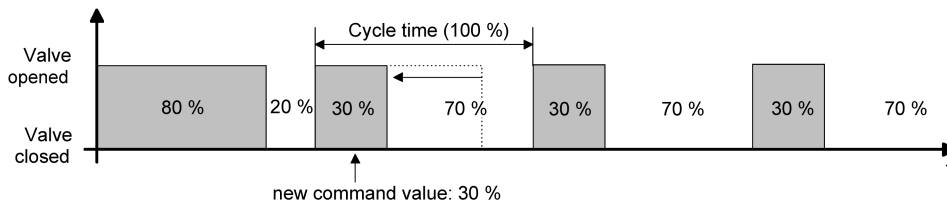

Image 8: Example of a command value change 80% -> 30% during the opening phase of the valve

– Case 2

Command value change, e.g. from 80% to 30%, during the closing phase of the valve (see figure 9).

Before the reception of the new command value (30%), the old setpoint (80%) was active. The new command value is received during the closing phase of the valve. At this point, the actuator detects that it is still possible to extend the closing phase, so that it corresponds to the new command value (30%). The cycle time remains unchanged, but the starting time of the period is shifted automatically.

The new duty factor is set immediately after the reception of the new command value.

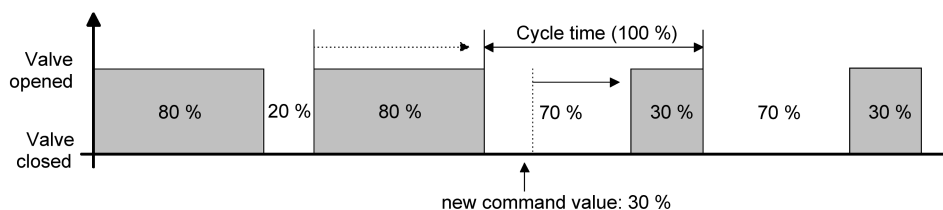

Image 9: Example of a command value change 80% -> 30% during the closing phase of the valve

– Case 3

Command value change, e.g. from 80% to 30% during the opening phase of the valve (opening phase too long) (see figure 10).  
 Before the reception of the new command value (30%), the old setpoint (80%) was active. The new command value is received during the opening phase of the valve. At this point, the actuator detects that it is necessary to cancel the opening phase immediately and close the valve, so that the duty factor corresponds to the new command value (30%). The cycle time remains unchanged, but the starting time of the period is shifted automatically.  
 The new duty factor is set immediately after the reception of the new command value.

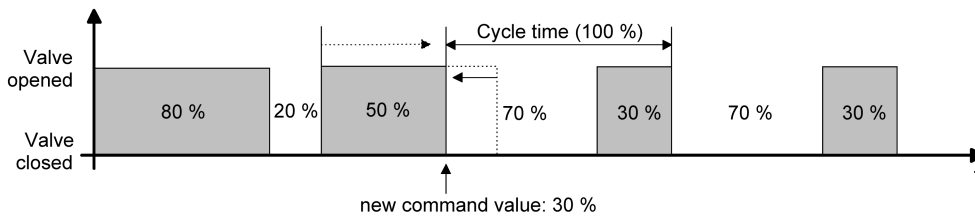

Image 10: Example of a command value change 80% -> 30% during the opening phase of the valve (opening phase too long)

– Case 4

Command value change, e.g. from 30% to 80%, during the opening phase of the valve (see figure 11).  
 Before the reception of the new command value (80%), the old setpoint (30%) was active. The new command value is received during the opening phase of the valve. At this point, the actuator detects that it is still possible to extend the open phase, so that it corresponds to the new command value (80%). The cycle time is not affected by this operation.  
 The new duty factor is set immediately after the reception of the new command value.

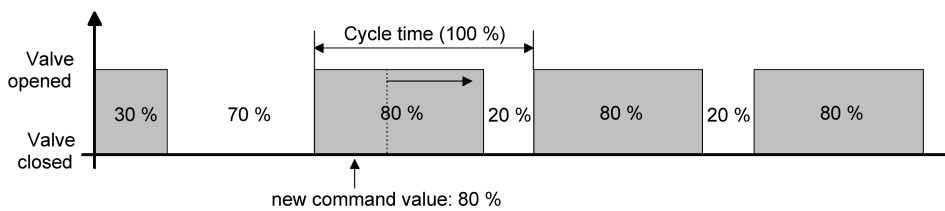

Image 11: Example of a command value change 30% -> 80% during the opening phase of the valve

– Case 5

Command value change, e.g. from 30% to 80%, during the closing phase of the valve (see figure 12).  
 Before the reception of the new command value (80%), the old setpoint (30%) was active. The new command value is received during the closing phase of the valve. At this point, the actuator detects that it is still possible to reduce the closing phase, so that it corresponds to the new command value (80%). The cycle time remains unchanged, but the starting time of the period is shifted

automatically.

The new duty factor is set immediately after the reception of the new command value.

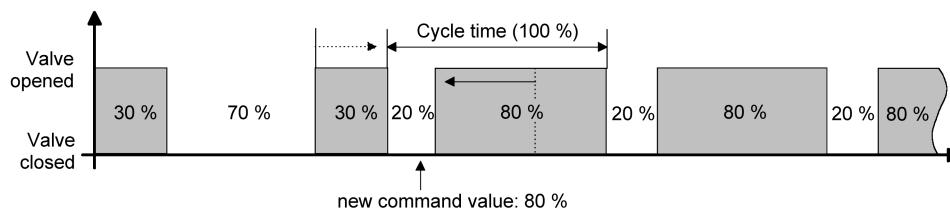

Image 12: Example of a command value change 30% -> 80% during the closing phase of the valve

#### – Case 6

Command value change, e.g. from 30% to 80%, during the closing phase of the valve (closing phase too long) (see figure 13).

Before the reception of the new command value (80%), the old setpoint (30%) was active. The new command value is received during the closing phase of the valve. At this point, the actuator detects that it is necessary to cancel the closing phase immediately and open the valve, so that the duty factor corresponds to the new command value (80%). The cycle time remains unchanged, but the starting time of the period is shifted automatically.

The new duty factor is set immediately after the reception of the new command value.

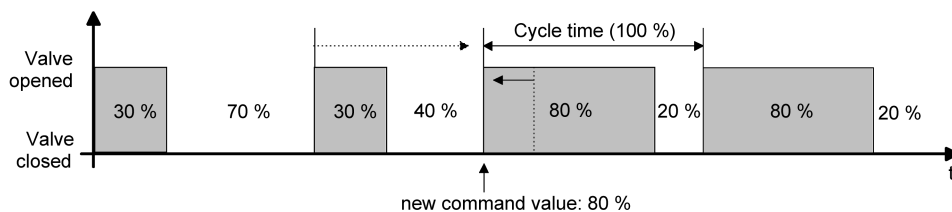

Image 13: Example of a command value change 30% -> 80% during the opening phase of the valve (opening phase too long)

### Data format of the command value input "Constant (1-byte) and activation with command value limiting value"

The data format with limiting value evaluation can be used as an alternative to the conversion of a 1-byte command value into constant pulse width modulation at a valve output. Here, the received constant command value is converted into a switching output signal, depending on the configured limiting value. The valve drive opens when the command value reaches the limiting value or exceeds it (see figure 14). A hysteresis is also evaluated to prevent constant closing and opening of the actuator for command values in the area of the limiting value. The valve drive only closes when the command value undershoots the limiting value minus the configured hysteresis.

The 1-byte data format with limiting value evaluation allows the conversion of constant feedback control by the heating actuator into a two-point controller. This principle is particularly suitable for underfloor heating, in which constant valve activation

does not produce the desired heating reaction, on account of the sluggishness. With sluggish underfloor heating systems, small constant command values (only short switch-on phases of the PWM) frequently do not produce any significant level of heating. With large constant command values, the short switch-off phases of a PWM usually have no effect on underfloor heating systems or comparable heating systems. Here, two-point feedback control offers a simple, effective alternative. The valves open or close completely. During activation, unnecessary constant valve positions are avoided using command value telegrams. In addition, the service life of the electrothermal actuators is increased.

The conversion of the constant input signal into a switching command value takes place internally in the device. During processing, the actuator evaluates the converted command value as if it were a received 1-bit command value. It forwards the status directly to the appropriate output, taking the configured valve direction of action into account. Thus, on a "Open valve" command (received command value  $\geq$  limiting value), the valve is opened completely. The output is then energised for energised closed valves and the output is deenergised for energised opened valve drives. On a "Close valve" command (received command value  $<$  limiting value - hysteresis), the valve is closed completely. The valve output is then not energised for deenergised closed valves and energised for deenergised opened valve drives.

As with a 1-bit input command value, in the functions and events listed below, valve outputs configured to the command value data formats "Constant (1-byte) and activation with command value limiting value" are always activated by a constant command value with pulse width modulation (PWM), provided that command values not equal to 0% or 100% are to be set...

- Active forced position,
- Active emergency operation,
- After bus voltage return,
- After an ETS programming operation,
- During a manual operation.

PWM keeps being executed until the named functions have been exited or, after the named events, no more lower-level functions are active and a new command value telegram is received via the bus, overriding the constant command value on the valve output.

- i** In the named cases, the constant command value is also included in the calculation of the largest command value and that of the heat requirement and pump control (optional functions).
- i** Valve outputs which receive preset command values via the data format "Switching (1-byte)" influence the heat requirement and pump control. Here, the actuator evaluates the converted switching output signal in the same way ("OFF" is interpreted as "0%", "ON" is interpreted as "100%").

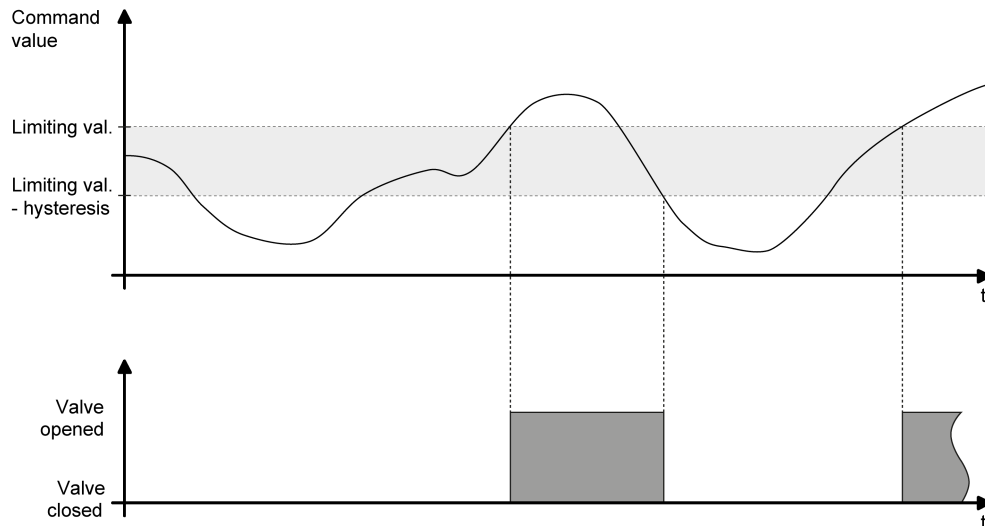

Image 14: Example of command value evaluation with limiting value

### 9.4.3 PWM cycle time

The "PWM cycle time" parameter specifies the period length of the pulse-width-modulated output signal of a valve output. It allows adaptation to the adjusting cycle times (the adjusting time it takes the drive to bring the valve from its completely closed to its completely opened position) of the valve drives used. In addition to the adjusting cycle time, take account of the dead time (the time in which the valve drives do not show any response when being switched on or off). If different actuators with different adjusting cycle times are used at an output, take account of the longest of the times.

- i** The "PWM cycle time" parameter is also available for valve drives whose command value data format is configured to "Switching (1-bit)" or "Constant (1-byte) with command value limiting value". For such valve outputs, pulse width modulation can also be executed during an active forced position, emergency operation, manual operation, after bus voltage return or after an ETS programming operation, for which, as a result, the presetting of a cycle time is required.

Generally, two different options of how to set the cycle time can be identified:

#### Case 1

Cycle time  $> 2 \times$  Adjusting cycle time of the drives used (ETA)

In this case, the switch-on and switch-off times of the actuator are long enough for the actuators to have sufficient time to fully open and fully close within a given period (see figure 15).

- Advantage:  
The desired mean value for the command value and thus for the required room temperature will be set relatively precisely, even for several actuators triggered at the same time.

- Disadvantage:  
It should be noted, that, due to the full valve lift, the life expectancy of the actuators can diminish. For very long cycle times (> 15 minutes) with less sluggishness in the system, the heat emission into the room, for example, in the vicinity of the radiators, can possibly be non-uniform and be found disturbing.
- i** This cycle time setting is recommended for slower, more sluggish heating systems (such as underfloor heating).
- i** Even for a bigger number of triggered actuators, maybe of different types, this setting can be recommended to be able to obtain a better mean value of the adjusting travels of the valves.

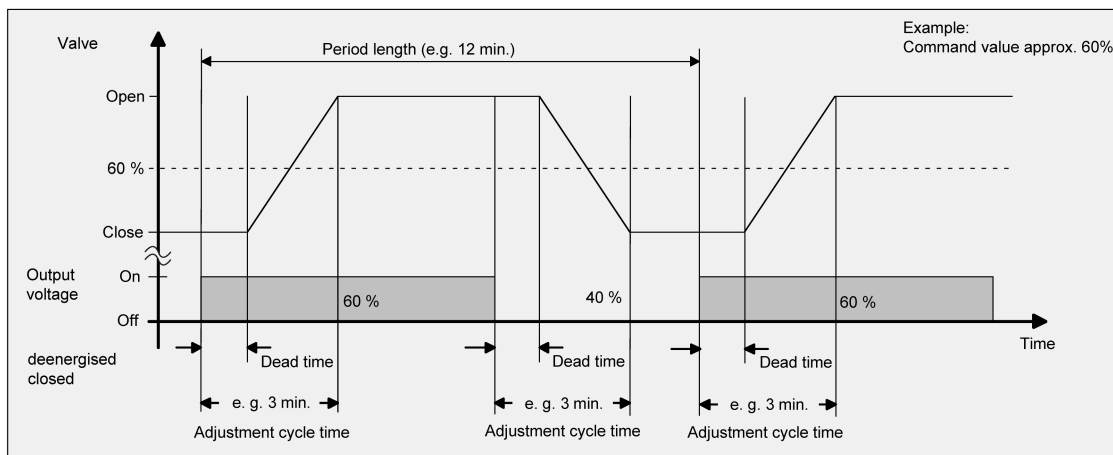

Image 15: Ideal course of the valve stroke for a  
Cycle time > 2 x Adjusting cycle time

## Case 2

Cycle time < Adjusting cycle time of the drives used (ETA)

In this case, the switch-on and switch-off times of the actuator are too short for the actuators to have enough time to fully open and fully close within a given period (see figure 16).

- Advantage: This setting ensures continuous water flow through the radiators, thus facilitating uniform heat emission into the room. If only one valve drive is triggered the controller can continuously adapt the command value to compensate the mean value shift caused by the short cycle time, thus setting the desired room temperature.
- Disadvantage: If more than one drive is activated at the same time, the desired mean value will become the command value, which will result in a very poor adjustment of the required room temperature, or in adjustment of the latter with major deviations, respectively.
- i** This setting is recommended for quicker heating systems (such as radiators).



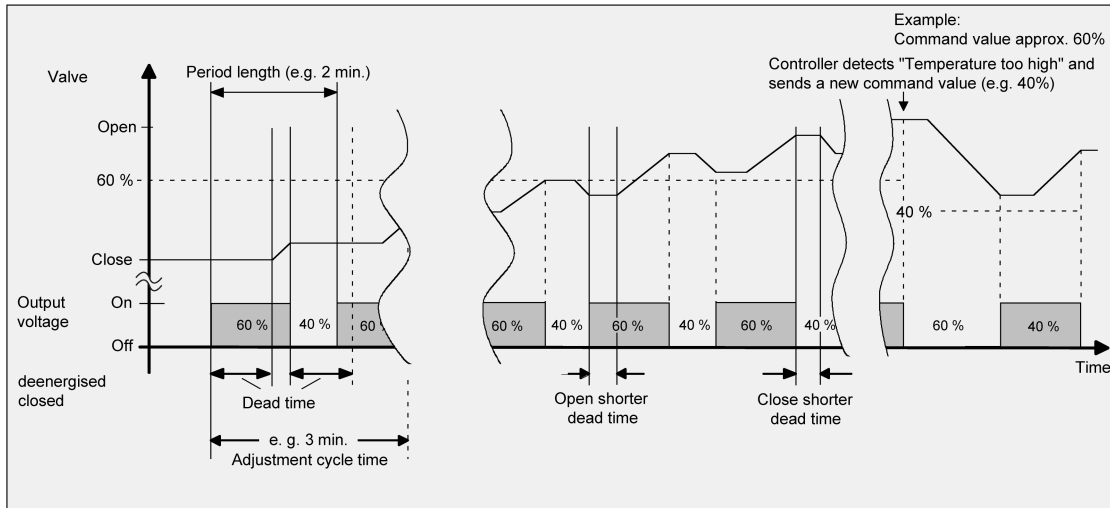

Image 16: Ideal course of the valve stroke for a Cycle time < Adjusting cycle time

The continuous flow of water through the valve, and thus the continuous heating of the drives causes variations and changes to the dead times of the drives during the opening and closing phase. The short cycle time and the dead times means that the required command value (mean value) is only set with a possibly large deviation. For the room temperature to be regulated constantly after a set time, the controller must continually adjust the command value to compensate for the mean value shift caused by the short cycle time. Usually, the control algorithm implemented in the controller (PI control) ensures that control deviations are compensated.

#### 9.4.4 Valve direction of action

The heating actuator possesses 6 electronic outputs, each of which can silently activate up to 4 (AC 230 V) or 2 (AC 24 V) actuators. Both deenergised closed and deenergised opened actuators can be connected. The parameter "In voltage-free state (direction of action)" on the parameter pages "VOx - General" specifies which drive type is connected to a valve output.

- i** Only actuators with the same characteristics may be connected to each valve output (deenergised closed/opened). The drive type must match the configuration.

The configured valve direction of action is taken into account in each valve activation. With 1-byte command values and deenergised closed valves, the switch-on time is derived directly from the configured PWM and the cycle time.

Example: PWM = 30%, cycle time = 10 minutes -> Switch-on time = 3 minutes, switch-off time = 7 minutes.

In the case of 1-byte command values and deenergised opened valves, the switch-on time is inverted. Example: PWM = 30%, cycle time = 10 minutes -> Switch-on time = 7 minutes, switch-off time = 3 minutes.

On deenergised closed valve drives, command values are not inverted, in accordance with the 1-bit data format. Example: Command value ON -> Output switched on, Command value OFF -> Output switched off.



By contrast, switching command values are inverted for deenergised opened valve drives. Example: Command value ON -> Output switched off, Command value OFF -> Output switched on.

- i** On the LED status display, the valve direction of action configured for each output in the ETS is not taken into account. As a result, the LEDs do not immediately display the valve state (opened / closed). Inversion of the status display according to the valve direction of action thus does not take place.
- i** In the as-delivered state, the valve direction of action for all the valve outputs is set to "deenergised closed".

### 9.4.5 Reset behaviour

The states of the valve outputs after bus voltage return or after an ETS programming operation can be set separately.

#### Setting the behaviour after bus voltage return

The parameter "After bus voltage return" is available separately for each valve output on the parameter page "VOx - General".

- Set the parameter to "Preset command value".

The actuator sets the command value preset for the valve output by the parameter "Command value". For valve outputs configured in the ETS to the command value data formats "Switching (1-bit)" or "Constant (1-byte) with command value limiting value", a constant command value can also be preset using the parameter "Command value". In this case, a pulse width modulation (5% ... 95%) is executed for the affected command value outputs. In the "0%" and "100%" presettings, the valve outputs are activated continuously. The preset PWM remains active until other functions have been executed or a new command value telegram is received via the bus, overriding the constant command value on the valve output.
- Set the parameter to "Activate command value according to forced position".

For the valve output, the actuator polls the command value preset for the forced position, as configured in the ETS. Here, the active operating mode (summer / winter) is taken into account, providing that a summer / winter change-over is configured. Ensure that, in this setting, the forced position function is not executed! The actuator only polls the command value preset for the forced position.
- Set the parameter to "Activate command value according to emergency operation".

For the valve output, the actuator polls the emergency operation command value, as configured in the ETS. Here, the active operating mode (summer / winter) is taken into account, providing that a summer / winter change-over is configured. Ensure that, in this setting, emergency operation is not executed

(as would be the case if there was a faulty command value found in the course of command value monitoring)! The actuator only polls the command value preset for emergency operation.

- Set the parameter to "Command value as before voltage failure".  
After bus voltage return, that command value is set at the valve output which was active at the moment of the last bus voltage failure. If there is a bus voltage failure, the actuator saves the active command value internally in the device, so that the command value can be restored when the device power supply returns.

**i** A valve state set after bus voltage return is added to the command value status objects. The status objects also only transmit after bus voltage return when the initialisation is complete and, if applicable, the "delay after voltage return" has elapsed.

### Presetting the behaviour after ETS programming

The parameter "After ETS programming" is available separately for each valve output on the parameter page "VOx - General". This parameter can be used to configure the behaviour of an output, irrespective of the behaviour after bus voltage return.

- Set the parameter "Command value as after voltage return".  
After an ETS programming operation, the valve output will behave in the manner defined in the parameter "After bus voltage return". If the behaviour there is configured to "Command value as before bus voltage failure", then that command value is also set after an ETS programming operation which was active at the time of the last bus voltage failure. An ETS programming operation does not overwrite the saved command value.
- Set the parameter to "Preset command value".  
The actuator sets the command value preset for the valve output by the parameter "Command value after ETS programming operation". For valve outputs configured in the ETS to the command value data formats "Switching (1-bit)" or "Constant (1-byte) with command value limiting value", a constant command value can also be preset using the parameter "Command value after ETS programming operation". In this case, a pulse width modulation (5% ... 95%) is executed for the affected command value outputs. In the "0%" and "100%" presettings, the valve outputs are activated continuously. The preset PWM remains active until other functions have been executed or a new command value telegram is received via the bus, overriding the constant command value on the valve output.
- Set the parameter to "Activate command value according to forced position".  
For the valve output, the actuator polls the command value preset for the forced position, as configured in the ETS. Here, the active operating mode (summer / winter) is taken into account, providing that a summer / winter change-over is configured. Ensure that, in this setting, the forced position function is not executed! The actuator only polls the command value preset for the forced position.

- Set the parameter to "Activate command value according to emergency operation".

For the valve output, the actuator polls the emergency operation command value, as configured in the ETS. Here, the active operating mode (summer / winter) is taken into account, providing that a summer / winter change-over is configured. Ensure that, in this setting, emergency operation is not executed (as would be the case if there was a faulty command value found in the course of command value monitoring)! The actuator only polls the command value preset for emergency operation.

- i** The behaviour after an ETS programming operation is only executed if there have been changes in the configuration of the device. If just an application download is executed with a project design already located in the actuator, then the actuator will execute the configured "Behaviour after bus voltage return".
- i** A valve state set after an ETS programming operation is added to the command value status objects. The feedback objects also only first transmit after an ETS programming operation when the initialisation has finished and, if necessary, the "delay time after bus voltage return" has elapsed.
- i** An active manual operation mode will be terminated by an ETS programming operation.

## 9.4.6 "Valve output - General" parameters

### Valve output x - General

Name of valve output	Free text
The text entered in this parameter is applied to the name of the communication objects and is used to label the valve output in the ETS parameter window (e.g. "Underfloor heating living room").	
The text is not programmed in the device.	

### Command value input

Data format	Switching (1-bit) Constant (1-byte)
The actuator can optionally be controlled via a 1-bit object or a 1-byte object.	
Switching (1-bit): In the case of a 1-bit command value, the telegram received internally in the device is forwarded directly to the output of the actuator, taking the configured valve direction of action into account.	
Constant (1-byte): In the case of a 1-byte command value, the following parameter "Activation with" determines the type of processing of the command value.	

**Valve output**

Activation with	<b>Pulse Width Modulation (PWM)</b> Command value limiting value
<p>Pulse width modulation (PWM): Command values are implemented by the actuator with an equivalent pulse-width-modulated switch signal at the valve output.</p> <p>Command value limiting value: The constant command value is converted into a switching output signal, depending on a configured limiting value.</p>	
Open valve from a command value limiting value of	1... <b>10</b> ...100 %
<p>In the 1-byte command value data with limiting value evaluation, the received constant command value is converted into a switching output signal, depending on the limiting value configured here. The valve drive opens when the command value reaches the limiting value or exceeds it.</p> <p>This parameter is only available in the case of "activation with command value limiting value".</p>	
Close valve if command value limiting value (hysteresis) falls below	1... <b>5</b> ...10 %
<p>In the 1-byte command value data with limiting value evaluation, the received constant command value is converted into a switching output signal. A hysteresis is also evaluated to prevent constant closing and opening of the actuator for command values in the area of the limiting value. The valve drive only closes when the command value undershoots the limiting value minus the configured hysteresis.</p> <p>This parameter is only available in the case of "activation with command value limiting value".</p>	

PWM cycle time	0.5 minutes 1 minute 1.5 minutes ... <b>15 minutes</b> ... 20 minutes
----------------	---

The "PWM cycle time" parameter specifies the switching frequency of the pulse-width-modulated output signal of the valve output. It allows adaptation to the adjusting cycle times (the adjusting time it takes the drive to bring the valve from its completely closed to its completely opened position) of the valve drives used. In addition to the adjusting cycle time, take account of the dead time (the time in which the actuators do not show any response when being switched or off). If different actuators with different adjusting cycle times are used at an output, take account of the longest of the times.

The "PWM cycle time" parameter is always available, irrespective of the data format and the activation type, because, in the case of an active forced position, emergency operation, after voltage return or after an ETS programming operation, the output is controlled with pulse width modulation for which, as a result, the specification of a cycle time is required.

## Valve

In voltage-free state (direction of action)	<b>closed</b> open
---	-----------------------

Valve drives that are closed or open when deenergised can be connected. On each electrical activation of the valve outputs, the actuator takes the valve direction of action configured here into account, so that the command value presettings (Valve closed OFF, 0% / Valve opened ON, 1...100%) can be executed in the correct direction of action. The valve outputs are no longer energised if the valve voltage supply fails or if there is a short-circuit or overload. The actuator takes this state into account and also influences the command value feedback, according to the configured valve direction of action.

**Reset behaviour**

After bus voltage return	<b>Specify command value</b> Activate command value acc. to forced position Activate command value acc. to emergency operation Command value as before voltage failure
<p>After bus or mains voltage return, the valve outputs perform the configured reaction at this point.</p> <p>Specify command value: The actuator sets the command value preset in the ETS for the valve output by the following parameter "Command value".</p> <p>Activate command value according to forced position: For the valve output, the actuator polls the command value preset for the forced position, as configured in the ETS. Here, the active operating mode (summer / winter) is taken into account, providing that a summer / winter change-over is configured.</p> <p>Ensure that, in this setting, the forced position function is not executed! The actuator only polls the command value preset for the forced position.</p> <p>Activate command value according to emergency operation: For the valve output, the actuator polls the emergency operation command value, as configured in the ETS. Here, the active operating mode (summer / winter) is taken into account, providing that a summer / winter change-over is configured.</p> <p>Ensure that, in this setting, emergency operation is not executed (as would be the case if there was a faulty command value found in the course of command value monitoring)! The actuator only polls the command value preset for emergency operation.</p> <p>Command value as before voltage failure: After bus or mains voltage return, that command value is set at the valve output which was active at the moment of the last bus voltage failure. If there is a bus voltage failure, the actuator saves the active command value internally in the device, so that the command value can be restored when the device power supply returns. Saving only takes place after a previous device reset (ETS programming operation, bus voltage return) when the reset is longer than 30 seconds previously. Otherwise the actuator does not save the current command value! In that case, an old value remains valid, as was previously saved by the actuator on the bus voltage failure.</p>	

Command value	0 % ... 100 %
<p>The command value to be set on bus voltage return is defined here. This parameter is only visible on "Behaviour after bus voltage return" = "Preset command value". For valve outputs configured in the ETS to the command value data formats "Switching (1-bit)" or "Constant (1-byte) with command value limiting value", a constant command value can also be preset using this parameter. In this case, a pulse width modulation (5% ... 95%) is executed for the affected command value outputs. In the "0%" and "100%" presettings, the valve outputs are activated continuously. The preset PWM remains active until other functions have been executed or a new command value telegram is received via the bus, overriding the constant command value on the valve output.</p>	

After ETS programming operation	Command value as after voltage return <b>Specify command value</b> Command value according to forced position Command value according to emergency operation
<p>After an ETS programming operation, the valve outputs perform the configured reaction at this point.</p> <p>Command value as after voltage return: After an ETS programming operation, the valve output behaves in the manner defined in the parameter "After bus voltage return". If the behaviour there is configured to "Command value as before voltage failure", then that command value is also set after an ETS programming operation which was active at the time of the last bus voltage failure. An ETS programming operation does not overwrite the saved command value.</p> <p>Specify command value: The actuator sets the command value preset in the ETS for the valve output by the following parameter "Command value".</p> <p>Command value according to forced position: For the valve output, the actuator polls the command value preset for the forced position, as configured in the ETS. Here, the active operating mode (summer / winter) is taken into account, providing that a summer / winter change-over is configured.</p> <p>Ensure that, in this setting, the forced position function is not executed! The actuator only polls the command value preset for the forced position.</p> <p>Command value according to emergency operation: For the valve output, the actuator polls the emergency operation command value, as configured in the ETS. Here, the active operating mode (summer / winter) is taken into account, providing that a summer / winter change-over is configured.</p> <p>Ensure that, in this setting, emergency operation is not executed (as would be the case if there was a faulty command value found in the course of command value monitoring)! The actuator only polls the command value preset for emergency operation.</p>	



Command value	0 % 5 % 10 % ... 90 % 95 % 100 %
<p>The command value to be set after an ETS programming operation is defined here. This parameter is only visible on "Behaviour after ETS programming operation" = "Preset command value".</p> <p>For valve outputs configured in the ETS to the command value data formats "Switching (1-bit)" or "Constant (1-byte) with command value limiting value", a constant command value can also be preset using this parameter. In this case, a pulse width modulation (5% ... 95%) is executed for the affected command value outputs. In the "0%" and "100%" presettings, the valve outputs are activated continuously. The preset PWM remains active until other functions have been executed or a new command value telegram is received via the bus, overriding the constant command value on the valve output.</p>	

### 9.4.7 Objects for "Valve output - General"

#### Function command value presetting

Object no.	Function	Name	Type	DPT	Flag
20, 35, 50, 65, 80, 96	Command value	VOx - Input (x = 1...6)	1-bit	1,001	C, (R), W, -, -
<p>1-bit input object for the presetting of a switching command value, e.g. of a KNX room temperature controller. In this case, the telegram polarity is fixed: "0" = Close valve, "1" = Open valve. The configured valve direction of action is taken into account in the electrical activation of the valve.</p> <p>This object is only available for valve outputs configured in the ETS to the command value data format "Switching (1-bit)".</p>					

#### Function command value presetting



Object no.	Function	Name	Type	DPT	Flag
21, 36, 51, 66, 81, 96	Command value	VOx - Input (x = 1...6)	1 bytes	5,001	C, (R), W, -, -
<p>1-byte input object for the presetting of a constant command value, e.g. of a KNX room temperature controller (0...100% -&gt; 0...255). This object is only available for valve outputs configured in the ETS to the command value data formats "Constant (1-bit) with pulse width modulation (PWM)" or "Constant (1-byte) with command value limiting value". With the command value format "Constant (1-byte) with pulse width modulation (PWM)", the telegram value is implemented by the actuator with an equivalent pulse-width-modulated switch signal at the valve outputs. The duty factor is adapted constantly by the actuator, depending on the command value received. The cycle time can be configured in the ETS. In accordance with the configured valve direction of action, the output is either energised or deenergised, depending on the valve position to be approached. In so doing, the duty factor is inverted automatically for a deenergised opened drive.</p> <p>In the command value format "Constant (1-byte) with command value limiting value", the received constant command value is converted into a switching output signal, depending on a configured limiting value. The valve drive opens when the command value reaches the limiting value or exceeds it. A hysteresis is also evaluated to prevent constant closing and opening of the actuator for command values in the area of the limiting value. The valve drive only closes when the command value undershoots the limiting value minus the configured hysteresis. The conversion of the constant input signal into a switching command value takes place internally in the device. During processing, the actuator evaluates the converted command value as if it were a received 1-bit command value. It forwards the status directly to the appropriate output, taking the configured valve direction of action into account.</p>					

## 9.5 Cyclical command value monitoring / emergency operation

If necessary, cyclical monitoring of the command values can be performed. If, during active cyclical monitoring, there are no command value telegrams during a preset time, then emergency operation is activated for the affected valve output, for which a configurable constant PWM command value can be preset in the ETS.

The command value of emergency operation is always constant and is configured individually in the ETS (0...100% in 10% steps). The command value is executed electrically at the output using a pulse width modulation (PWM).

- i** When emergency operation is active, valve outputs configured to the command value data formats "Switching (1-bit)" or "Constant (1-byte) with command value limiting value" are always activated by a constant command value with pulse width modulation. In this case, this constant command value is also included in the calculation of the largest command value (optional function) until the emergency operation is exited and no other function with a constant command value presetting (e.g. forced position, manual operation) is active.

- i** The configured valve direction of action (deenergised closed / deenergised opened) is taken into account in the electrical activation of the outputs by emergency operation. With deenergised closed valves, the switch-on time is derived directly from the configured PWM and the cycle time. In the case of deenergised opened valves, the switch-on time is inverted.

The actuator possesses a summer / winter switchover. Depending on the season, this allows the setting of different command value setpoints for a valve output for emergency operation Summer/winter switch-over for valve outputs. It is also possible to switch over the operating mode during active emergency operation. In this case, the value belonging to the operating mode is activated immediately after the switchover.

If no summer / winter switchover is planned in the actuator, then only a command value can be configured in the ETS for emergency operation.

If command value monitoring is enabled, then the actuator will check the arrival of telegrams on the command value object during a settable time period. The time period is defined separately for each valve output by the "Monitoring cycle" parameter. The time set there should be at least double the time for the cyclical transmission of the command value of the controller, in order to ensure that at least one telegram is received within the monitoring time. Cyclical command value monitoring takes place continuously. The actuator retriggers the monitoring time automatically on each command value telegram received and after a device reset. If there are no command value telegrams during the monitoring time, then the actuator will activate emergency operation.

- i** If the bus control of a valve output was disabled during permanent manual operation, then no command value monitoring is performed for the affected output. This exits active emergency operation. When bus control is enabled by a permanent manual operation, the actuator restarts the monitoring time and checks for incoming command value telegrams.

According to the priority control, active command value monitoring can be overridden by other device functions with a higher priority (e.g. service mode, manual operation). At the end of a higher priority function, the actuator executes emergency operation for the valve outputs concerned once again, if it is still activated by missing command value telegrams.

Optionally, the command value of emergency operation can also be activated after bus voltage return or after an ETS programming operation. This is only the recall of the configured command value and not the activation of emergency operation, as takes place during command value monitoring.

- i** The command value preset by active emergency operation is also included in the determination of heat requirement. In addition, the command value of emergency operation has an influence on the pump control.

At the end of emergency operation (new input command value received), the behaviour of a valve output is permanently defined. If no function with a higher priority is active, the actuator always tracks the state for the affected valve outputs most recently preset by normal bus operation (activation by command value telegrams).

- i** After a device reset (bus voltage return, ETS programming operation), the command value objects first contain the value "0".
- i** The state or emergency operation (active or inactive) is saved internally in the device after a bus voltage failure and is restored automatically after a bus voltage return. After a bus voltage return, the actuator activates emergency operation, if the tracked state allows this.

The actuator makes the 1-bit status telegram "Command value fault" available. As soon as a command value telegram is missing on a monitored valve output, and thus emergency operation is activated, then the actuator transmits a fault signal via this status object. The telegram polarity can be configured. Only after at least one command value telegram has been received for the monitored valve output does the actuator retract the fault signal for cyclical monitoring. Optionally, the fault telegram can also be transmitted cyclically during active emergency operation.

- i** Immediately after the bus voltage return or an ETS programming operation, the object "Command value - Fault - Status" does not transmit the status automatically. A faulty command value must be detected again (expiry of the monitoring time without a command value telegram) for the object value to be transmitted. This is also the case if a saved emergency operation was restored after a device reset.

### **Enabling cyclical command value monitoring**

Cyclical command value monitoring can only be used if it has been enabled in the ETS.

- Activate the checkbox "Command value monitoring" on the "VOx - General - Enable functions" parameter page. Configure the "Monitoring cycle" of the command value monitoring.

Cyclical command value monitoring is activated. If there are no command value telegrams during the monitoring cycle preset by the parameter of the same name, then emergency operation is activated for the affected valve output, for which the actuator sets a constant PWM command value. This command value is defined on the parameter page "VOx - General - Emergency operation" by the parameter "Command value" (separately for summer and winter if required).

- Deactivate the checkbox "Command value monitoring".  
Cyclical command value monitoring is deactivated.

### **Configuring the fault signal for cyclical command value monitoring**

If a command value fault is identified, then the actuator can optionally transmit a fault telegram via the object "Command value fault".

- Set the parameter "Object polarity" on the parameter page "VOx - General - Command value monitoring" to the required telegram polarity.

As soon as a command value telegram is missing on a monitored valve output, and thus emergency operation is activated, then the actuator transmits a fault signal via the object "Command value - Fault - Status" according to the configured telegram polarity. Only after at least one command value telegram has been received for the monitored valve output does the actuator retract the fault signal for cyclical monitoring.

- Activate the checkbox "Cyclical transmission in the case of faulty command value".

If a command value fault is identified, then the actuator transmits the fault telegram cyclically. The cycle time is defined for all cyclical status and feedback functions on the parameter page "General - Valve outputs".

- Deactivate the checkbox "Cyclical transmission in the case of faulty command value".

If a command value fault is identified, then the actuator transmits the fault telegram only once.

### 9.5.1 Command value monitoring / emergency operation parameters

#### Enabling the function "Command value monitoring"

VOx - General -> Enabled functions

Command value monitoring	Checkbox (yes / no)
Here, cyclical monitoring of the command values can be enabled as an option ("Yes" setting). If, in active cyclical monitoring, there are no command value telegrams during the monitoring time preset by the parameter of the same name, then emergency operation is activated for the affected valve output, for which a configurable constant PWM command value can be preset.	

#### Setting the function "Command value monitoring"

VOx - General -> Command value monitoring

Monitoring cycle	0...20...59 min 0...59 s
This parameter specifies the monitoring cycle of the command value monitoring. The actuator must receive at least one command value telegram within the time frame specified here. If there is no command value telegram, then the actuator will assume a fault and will activate emergency operation for the affected valve output. This parameter is only available if command value monitoring is enabled. Presetting of the monitoring time minutes and seconds.	

Object polarity	1 = fault / 0 = no fault / 0 = fault / 1 = no fault
<p>If a command value fault is identified, then the actuator can optionally transmit a fault telegram via the object "Command value - Fault - Status". This parameter defines the telegram polarity of the fault telegram.</p> <p>This parameter is only available if command value monitoring is enabled.</p>	
Cyclical transmission in the case of faulty command value	Checkbox (yes / no)
<p>If a command value fault is identified, then the actuator can optionally transmit the fault telegram cyclically. Here, the cyclical transmission of the fault telegram can be enabled as required ("Yes" setting).</p> <p>This parameter is only available if command value monitoring is enabled.</p>	

### 9.5.2 Objects for command value monitoring / emergency operation

Function: Command value monitoring

Object no.	Function	Name	Type	DPT	Flag
25, 40, 55, 70, 85, 100	Command value - Fault - Status	VO x - Output (x = 1...6)	1-bit	1,005	C, R, -, T, -
<p>1-bit output object to signal a faulty command value (with active command value monitoring, no command value telegram was received within the monitoring time). The telegram polarity can be configured.</p> <p>Immediately after the bus voltage return or an ETS programming operation, the object "Command value fault" does not transmit the status automatically. A faulty command value must be detected again (expiry of the monitoring time without a command value telegram) for the object value to be transmitted. This is also the case if a saved emergency operation was restored after a device reset.</p>					

## 9.6 Command value limit

### Enabling the command value limit

The command value limit can only be used if it has been enabled in the ETS.

- Set the parameter "Command value limit" on the parameter page "VOx - General - Enabled functions" to "yes".

The command value limit is enabled. The "Activation" parameter defines whether the limiting function can be activated or deactivated as required via a communication object. Alternatively, the command value limit can be permanently active.
- Set the parameter "Command value limit" to "no".

The command value limit is not available.

### Setting the activation of the command value limit

The "Activation" parameter on the parameter page "VOx - General - Command value monitoring" defines the type of action of the limiting function.

The command value limit must be enabled.

- Set the parameter to "via object".  
The command value limit can only be activated using the 1-bit communication object "Command value limit - Activate / Deactivate" ("1" telegram) or deactivated ("0" telegram). The behaviour of the command value limit is definable separately after a device reset (bus voltage return, ETS programming operation).
- Set the parameter to "permanently active".  
The command value limit is permanently active. It cannot be influenced via an object. Command values preset via the KNX or via emergency operation are always limited.

### Setting the initialisation behaviour of the command value limit

The command value limit can either be activated or deactivated using the 1-bit communication object "Command value limit - Activate / Deactivate" or be permanently active. When controlling via the object, it is possible to have the actuator activate the command value limit automatically after bus voltage return or an ETS programming operation. The parameters "Activate after bus voltage return" and "Activate after ETS programming operation" define the initialisation behaviour.

- i** With a permanently active command value limit, the initialisation behaviour cannot be configured after bus voltage return or an ETS programming operation, as the limit is always active. In this case, no object is available.

The command value limit must be enabled.

- Set the parameter "Active after bus voltage return" to "no".  
The command value limit is not activated automatically after bus voltage return. A "1" telegram must first be received via the "Command value limit" object for the limiting function to be activated.
- Set the parameter "Active after bus voltage return" to "yes".  
In this setting, the actuator does not activate the command value limit automatically after bus voltage return. To deactivate the limit a "0" telegram must be received via the "Command value limit" object. The limit can be switched on or off at any time using the object.
- Set the parameter "Active after ETS programming operation" to "no".  
The command value limit is not activated automatically after an ETS programming operation. A "1" telegram must first be received via the "Command value limit" object for the limiting function to be activated.
- Set the parameter "Active after ETS programming operation" to "yes".



In this setting, the actuator activates the command value limit automatically after an ETS programming operation. To deactivate the limit a "0" telegram must be received via the "Command value limit" object. The limit can be switched on or off at any time using the object.

- i** The status of the command value limit is not automatically tracked in the communication object after a device reset.
- i** It is to be noted that, on account of priority control, the actuator executes the behaviour configured by the parameters "Behaviour after bus voltage return" and "Behaviour after an ETS programming operation" on the parameter page "VOx - General" after bus voltage return and an ETS programming operation. The command values preset via configuration after a device reset are not influenced by a command value limit. A command value limit only influences the input command values preset via the bus or emergency operation command values during command value monitoring.

### 9.6.1 Command value limit parameters

#### Enabling the function "Command value limit"

VOx - General -> Enabled functions

Command value limit	Checkbox (yes / no)
This parameter enables the command value limit. The command value range is defined by a configurable smallest and a configurable largest command value.	

#### Setting the function "Command value limit"

VOx - General -> Command value limit

Activation	via object permanently active
This parameter decides whether the limit of the command values can either be activated and deactivated by the "Command value limit" object or whether the command value limit is permanently active.	

Active after bus voltage return	Checkbox (yes / no)
This parameter decides whether the command value limit is activated or inactive after voltage return.	

Active after ETS programming operation	Checkbox (yes / no)
This parameter decides whether the command value limit is activated or inactive after an ETS programming operation.	

Minimum command value	0 ... 50%
The minimum command value that is valid when the command value limit is activated is defined here.	

Maximum command value	55 ... 100%
The maximum command value that is valid when the command value limit is activated is defined here.	

## 9.6.2 Objects for command value limit

Function: Command value limit

Object no.	Function	Name	Type	DPT	Flag
26, 41, 56, 71, 86, 101	Command value limit - Activate / Deactivate	VO x - Input (Xx = 1...6)	1-bit	1,002	C, (R), W, -, -
<p>1-bit input object for requirement-orientated activating and deactivating of a command value limit. The telegram polarity is fixed: "0" = Command value limit inactive, "1" = Command value limit active. Updates of the object from "1" to "1" or "0" to "0" do not produce a reaction.</p> <p>If required, this object is only available for valve outputs configured in the ETS to the command value data format "Constant (1-byte) with pulse width modulation (PWM)". It is possible to have the actuator activate the command value limit automatically after bus voltage return or an ETS programming operation. The status of the command value limit is not then automatically tracked in the communication object.</p>					

## 9.7 forced position

A forced position can be configured separately for each valve output and activated according to requirements. If a forced position is active, a defined command value is set at the output. Affected valve outputs are then locked so that they can no longer be activated using functions subject to the forced position (including activation by command value telegrams).

The command value of the forced position is always constant and is configured individually in the ETS (0...100% in 10% steps). The command value is executed electrically at the output using a pulse width modulation (PWM).

- i** When a forced position is active, valve outputs configured to the command value data formats "Switching (1-bit)" or "Constant (1-byte) with command value limiting value" are always activated by a constant command value with pulse width modulation. In this case, this constant command value is also included in the calculation of the largest command value (optional function) until the forced position is exited and no other function with a constant command value presetting (e.g. emergency operation, manual operation) is active.
- i** The configured valve direction of action (deenergised closed / deenergised opened) is taken into account in the electrical activation of the outputs by a forced position. With deenergised closed valves, the switch-on time is derived directly from the configured PWM and the cycle time. In the case of deenergised opened valves, the switch-on time is inverted.



The actuator possesses a summer / winter switchover. Depending on the season, this allows the setting of different command value setpoints for a valve output for forced position Summer/winter switch-over for valve outputs. It is also possible to switch over the operating mode during an active forced position. In this case, the value belonging to the operating mode is activated immediately after the switchover. If no summer / winter switchover is planned in the actuator, then only a command value can be configured in the ETS for the forced position.

For each valve output, the forced position is activated and deactivated via a separate 1-bit object. The telegram polarity can be configured. According to the priority control, an active forced position can be overridden by other device functions with a higher priority (e.g. service mode, manual operation). At the end of a higher priority function, the actuator executes the forced reaction for the valve outputs concerned once again if the forced position is still activated at this time.

Optionally, the command value of the forced position can also be activated in case of bus voltage failure, after bus/mains voltage return or after an ETS programming operation. This is only the recall of the configured command value and not the activation of the forced position as takes place via the 1-bit object.

- i** The command value preset by an active forced position is also included in the determination of heat requirement. In addition, the command value of the forced position has an influence on the pump control.

At the end of a forced position, the behaviour of a valve output is permanently defined. For the affected valve outputs, the actuator always tracks the state most recently preset by functions with a lower priority (emergency operation) or by normal bus operation (activation by command value telegrams).

- i** After a device reset (bus voltage return, ETS programming operation), the command value objects first contain the value "0".

### Enabling the forced position object and configuring the forced position

For the forced position to be used as a locking function, it must first be enabled in the ETS on the parameter page "VOx - General - Enabled functions". This switches the parameter page "VOx - General - Forced position" to visible. The remaining parameters are set there.

- Set the parameter "Forced position controllable via object" to "yes". Define the parameter "Object polarity" to the required telegram polarity. In addition, configure the required command values (optional for summer and winter mode).

The forced position object is enabled. The affected valve output is locked by a telegram according to the "Forced operation active" polarity at the defined command value (optional according to the most recently preset operating mode).

- Set the parameter "Forced position controllable via object" to "no".

The forced position object is not enabled. The forced position for locking the valve output is not possible. Only the command values can be configured, so that a state for the reset behaviour of the valve output can be optionally defined.

- i** Updates of the object from "Forced position active" to "Forced position active" or from "Forced position inactive" to "Forced position inactive" produce no re-action.
- i** The status preset via the forced position object is stored internally in the device after a bus voltage failure and is restored automatically after a bus voltage return. After a bus voltage return, the actuator activates the forced position, if the tracked state allows this. However, when presetting the command values, only that behaviour is significant, according to the priority sequence, which the parameter "After bus voltage return" defines (the command value of the forced position is not activated).  
The tracked state of the forced position is not then automatically tracked in the communication object by the actuator.
- i** After an ETS programming operation, a forced position is always deactivated and the forced position object is "0". In the polarity "0" = Forced position active / "1" = No forced position, a "0" telegram must first be received to activate the forced position.  
If, after a bus voltage return, the previously stored object value "0" is restored, then actuator will also activate the forced position in the polarity "0 = Forced position active / 1 = No forced position", thus locking the output.
- i** If the forced position object is not enabled, then only the command value parameters are available, so that valid preset values are available for the actuator reset behaviour, as required ("Activate command value according to forced position").

### 9.7.1 "Forced position" parameters

VOx - General -> Forced position

Command value	0 %
	10 %
	...
	<b>30 %</b>
	...
	90 %
	100 %

When forced operation is activated via a 1-bit object, after voltage return or after an ETS programming operation, it is possible to set the forced command value configured here as the active command value.

When the command value of the forced position is recalled, the valve output configured to the command value data formats "Switching (1-bit)" or "Constant (1-byte) with command value limiting value" is always activated by a constant command value with pulse width modulation.

Command value (summer)	0 %
	10 %
	...
	<b>30 %</b>
	...
	90 %
	100 %

When forced operation is activated via a 1-bit object, after voltage return or after an ETS programming operation, it is possible to set the forced command value configured here as the active command value. The command value preset here is only applied if summer operation is activated.

When the command value of the forced position is recalled, the valve output configured to the command value data formats "Switching (1-bit)" or "Constant (1-byte) with command value limiting value" is always activated by a constant command value with pulse width modulation.

Command value (winter)	0 %
	10 %
	...
	<b>70 %</b>
	...
	90 %
	100 %

When forced operation is activated via a 1-bit object, voltage return or after an ETS programming operation, it is possible to set the forced command value configured here as the active command value. The command value preset here is only applied if winter mode is activated.

When the command value of the forced position is recalled, the valve output configured to the command value data formats "Switching (1-bit)" or "Constant (1-byte) with command value limiting value" is always activated by a constant command value with pulse width modulation.

Forced position controllable via object	Checkbox (yes / no)
<p>This parameter enables the "Forced position - Activate / Deactivate" object.</p> <ul style="list-style-type: none"> <li>- Yes: The object "Forced position - Activate / Deactivate" is visible. The forced position is activated and deactivated via a separate 1-bit object.</li> <li>- No: The configured forced command values are used for the reset behaviour after voltage return and after ETS programming operation. A forced position cannot be activated.</li> </ul>	

Object polarity	<p>1 = forced position active / 0 = no forced position</p> <p>0 = forced position active / 1 = no forced position</p>
<p>The telegram polarity of the "Forced position - Activate / Deactivate" object is defined here when the forced position object is enabled.</p>	

Status object	Checkbox (yes / no)
<p>This parameter enables the "Forced position - Status" object.</p> <ul style="list-style-type: none"> <li>- Yes: The "Forced position - Status" object is visible. The polarity of the object is defined: 1 = forced position active / 0 = no forced position</li> <li>- No : The "Forced position - Status" object is not visible.</li> </ul>	

### 9.7.2 Objects for forced position

Object no.	Function	Name	Type	DPT	Flag
24, 39, 54, 69, 84, 99	Forced position - Activate / Deactivate	VO x - Input	1-bit	1,003	C, -, W, -, U

1-bit input object for activating and deactivating of a forced position. The telegram polarity can be configured.

- i** Updates of the object from "Forced position active" to "Forced position active" or from "Forced position inactive" to "Forced position inactive" produce no reaction.
- i** The status preset via the forced position object is stored internally in the device after voltage failure and is restored automatically after voltage return.

Object no.	Function	Name	Type	DPT	Flag
32, 47, 62, 77, 96, 107	Forced position - Status	VO x - Output	1-bit	1,003	C, R, -, T, A

1-bit output object for status message of a forced position. The polarity of the object is defined: 1 = forced position active / 0 = no forced position

## 9.8 Command value status

### Command value status

A status object can be optionally enabled for each valve output. The status object makes the active command value of a valve output available either actively transmitting or passively (object can be read out). In the status message, the actuator takes all the functions into account which have an influence on the command value implemented at the output. Depending on the configured data format of the input command value, the status object will possess the data formats named below...

- Input command value "Switching (1-bit)":  
Data format of status object "1-bit",

- Input command value "Constant (1-byte) with pulse width modulation (PWM)":  
Data format of status object "1-byte",
- Input command value "Constant (1-byte) command value limiting value":  
Data format of status object "1-bit".

The status objects will assume different status values, depending on the input data formats of the command values and the state of operation of a valve output.

- i** The actuator distinguishes between different functions and events that can have an effect on the valve outputs. Because these functions and events cannot be executed simultaneously, there is priority control. Each global or output-orientated function and each incoming event possesses a priority. Priorities for valve outputs. The function or the event with the higher priority overrides the lower-priority functions and events.
- Priority control also influences the status objects. That state is always transmitted as the status which is currently set at a valve output. If a function with a high priority is exited, then the status objects assume the command value of functions with a lower priority, providing that they are active.

Status value for input command value "Switching (1-bit)"...

- State of operation "Normal operation"  
-> Status value = Most recently received input command value ("0" or "1"),
- State of operation "Emergency operation" (0...100%)  
-> Status value = Emergency operation command value ("0" at 0%, "1" at 1...100%),
- State of operation "Forced position" (0...100%)  
-> Status value = Forced command value ("0" at 0%, "1" at 1...100%),
- State of operation "Valve rinsing" (0%, 100%)  
-> Status value = Current command value in rinsing operation ("0" when valve closed, "1" when valve opened),
- State of operation "Service mode" (0%, 100%)  
-> Status value = Service command value ("0" when valve forcibly closed, "1" when valve forcibly opened),
- State of operation "After device reset" (0...100%)  
-> Status value = According to presetting by parameter "Behaviour after bus or mains voltage return" or "Behaviour after ETS programming operation" ("0" at 0%, "1" at 1...100%),
- State of operation "Manual operation" (5...100%)  
-> Status value = Manual operation mode command value ("0" at 0% CLOSE, "1" at 5...100% OPEN),
- State of operation "Valve voltage failure" (0%, 100%)  
-> Status value = Command value according to valve direction of action ("0" when deenergised closed, "1" when deenergised opened),
- State of operation "Short-circuit / overload" (0%, 100%)  
-> Status value = Command value according to valve direction of action ("0" when deenergised closed, "1" when deenergised opened).

Status value for input command value "Constant (1-byte) with pulse width modulation (PWM)"...

- State of operation "Normal operation" -> Status value = Most recently received input command value (0...100%),
- State of operation "Emergency operation" (0...100%)  
-> Status value = Emergency operation command value (0...100%),
- State of operation "Forced position" (0...100%)  
-> Status value = Forced command value (0...100%),
- State of operation "Valve rinsing" (0%, 100%)  
-> Status value = Current command value in rinsing operation ("0%" when valve closed, "100%" when valve opened),
- State of operation "Service mode" (0%, 100%)  
-> Status value = Service command value ("0%" when valve forcibly closed, "100%" when valve forcibly opened),
- State of operation "After device reset" (0...100%)  
-> Status value = According to presetting by parameter "Behaviour after bus or mains voltage return" or "Behaviour after ETS programming operation" ("0" at 0%, "1" at 1...100%),
- State of operation "Manual operation" (5...100%)  
-> Status value = Manual operation mode command value (0% CLOSE, 5...100% OPEN),
- State of operation "Valve voltage failure" (0%, 100%)  
-> Status value = Command value according to valve direction of action (0% when deenergised closed, 100% when deenergised opened),
- State of operation "Short-circuit / overload" (0%, 100%)  
-> Status value = Command value according to valve direction of action (0% when deenergised closed, 100% when deenergised opened).

Status value for input command value "Constant (1-byte) command value limiting value"...

- State of operation "Normal operation"  
-> Status value = According to evaluation of the input command value by limiting value and hysteresis ("0" for command value < limiting value - hysteresis or "1" for command value >= limiting value),
- State of operation "Emergency operation" (0...100%)  
-> Status value = Emergency operation command value ("0" at 0%, "1" at 1...100%),
- State of operation "Forced position" (0...100%)  
-> Status value = Forced command value ("0" at 0%, "1" at 1...100%),
- State of operation "Valve rinsing" (0%, 100%)  
-> Status value = Current command value in rinsing operation ("0" when valve closed, "1" when valve opened),
- State of operation "Service mode" (0%, 100%)  
-> Status value = Service command value ("0" when valve forcibly closed, "1" when valve forcibly opened),



- State of operation "After device reset" (0...100%)  
-> Status value = According to presetting by parameter "Behaviour after bus or mains voltage return" or "Behaviour after ETS programming operation" ("0" at 0%, "1" at 1...100%),
- State of operation "Manual operation" (5...100%)  
-> Status value = Manual operation mode command value ("0" at 0% CLOSE, "1" at 5...100% OPEN),
- State of operation "Valve voltage failure" (0%, 100%)  
-> Status value = Command value according to valve direction of action ("0" when deenergised closed, "1" when deenergised opened),
- State of operation "Short-circuit / overload" (0%, 100%)  
-> Status value = Command value according to valve direction of action ("0" when deenergised closed, "1" when deenergised opened).

### Activating the command value status function

The status message of the valve command value is a function of the valve outputs and can be enabled on the parameter pages "VOx - General -> Status".

- Set the "Valve command value" parameter to "yes".  
Status feedback is enabled. The status object of the valve output becomes visible in the ETS.
- Set the parameter to "no".  
Status feedback is deactivated. No status object is available.

The feedback telegram is transmitted as soon as the status changes. An automatic telegram transmission of the feedback takes place after bus voltage return, if the supply voltage of the actuators fails and returns or after an ETS programming operation (possibly with a delay).

- i** The status object does not transmit if the status does not change after the activation or deactivation of device functions or new input command values. Transmission only ever takes place after changes to the command value.

### Setting the time delay of the command value status feedback

The state of the status message is not transmitted automatically to the bus after bus voltage return or an ETS programming operation. In these cases, feedback can be time-delayed with the time delay being preset globally for all valve outputs together on the "General" parameter page.

- Set the parameter "Delay after bus voltage return" to "yes".  
The status message is transmitted with a delay after bus voltage return or after an ETS programming operation. No feedback is transmitted during a running time delay, even if the valve state changes during this delay.
- Set the parameter "Delay after bus voltage return" to "no".  
The status message is transmitted immediately after bus voltage return or after an ETS programming operation.

- i** If the supply voltage of the actuators fails and returns, then the status message is always transmitted without a delay, providing that the bus voltage supply is switched on.

### Setting cyclical transmission of the command value status message

The status message telegram can also be transmitted cyclically via the object in addition to the transmission after changes.

- Set the parameter "Transmit on" to "change and cyclical".  
Cyclical transmission is activated.
  - Set the parameter "Transmit on" to "change".  
Cyclical transmission is deactivated so that the status is transmitted to the bus only when changed by the actuator.
- i** The cycle time is defined centrally for all the valve outputs on the parameter page "General".
  - i** There is no cyclical transmission during an active time delay after bus voltage return or an ETS programming operation.

## 9.8.1 Status parameters

Valve output x - General -> Enabled functions

Status	Checkbox (yes / no)
This parameter generally enables the feedback functions. The feedback functions are configured on the "Status" parameter page.	

Valve output x - General -> Status

Valve command value	Active Inactive
This parameter enables the status object "Command value - Status". The data point type corresponds to the input object "Command value" The status object makes the active command value of the valve output available. All functions are taken into account that have an influence on the command value implemented at the output.	



Transmit on	<b>Change</b> Change and cyclical
<p>The status feedback telegram can also be transmitted cyclically via the active signal object in addition to the transmission after changes.                  This parameter is only visible in case of enabled status feedback.</p> <p>Change: Cyclical transmission is deactivated so that the feedback telegram is transmitted to the bus only when the status is changed by the actuator.</p> <p>Change and cyclical: Cyclical transmission is activated. The cycle time is defined centrally for all the valve outputs on the parameter page "General valve outputs".                  There is no cyclical transmission during an active time delay after voltage return or an ETS programming operation.</p>	

Delay after bus voltage return	Checkbox (yes / no)
<p>If used as active signal object, the state of the status feedback information is transmitted to the bus after voltage return or after an ETS programming operation. In these cases, feedback can be time-delayed with the time delay being preset globally for all valve outputs together on the "General valve outputs" parameter page.                  This parameter is only visible in case of enabled status feedback.</p> <p>Active: The status feedback is transmitted with a delay after voltage return or after an ETS programming operation. No feedback is transmitted during a running time delay, even if the valve state changes during this delay.</p> <p>Inactive: The status feedback is transmitted without delay after voltage return or after an ETS programming operation.</p>	

### 9.8.2 Objects for status

Function: Valve status

Object no.	Function	Name	Type	DPT	Flag
22, 37, 52, 67, 82, 97	Status command value	VO x - Output (x = 1...6)	1-bit	1,001	C, R, -, T, -
<p>1-bit output object to feed back the active switching command value of a valve output. In this case, the telegram polarity is fixed: "0" = Valve closed, "1" = Valve opened.</p> <p>This object is only available for valve outputs configured in the ETS to the command value data formats "Switching (1-bit)" or "Constant (1-byte) with command value limiting value".</p> <p>It may also occur with such command value outputs that a constant command value (PWM at the output) is active (e.g. after bus/mains voltage return or a forced position and emergency operation or manual operation). In this case, the status object feeds back a "0" if the command value corresponds to "0%". The object returns a "1" when the set command value corresponds to "1...100%".</p> <p>The object transmits the current status after bus voltage return and an ETS programming operation, possibly after a transmission delay (configurable) has elapsed.</p>					

Object no.	Function	Name	Type	DPT	Flag
23, 38, 53, 68, 83, 98	Status command value	VO x - Output (x = 1...6)	1 bytes	5,001	C, R, -, T, -
<p>1-byte output object to feed back the active constant command value of a valve output (0...100% -&gt; 0...255).</p> <p>This object is only available for valve outputs configured in the ETS to the command value data format "Constant (1-byte) with pulse width modulation (PWM)".</p> <p>The object transmits the current status after bus voltage return and an ETS programming operation, possibly after a transmission delay (configurable) has elapsed.</p>					

## 9.9 Short-circuit and overload detection

The actuator is able to detect an electrical overload or a short-circuit at the valve outputs and to protect them against destruction by switching off. Outputs which have experienced a short-circuit or a constant load are deactivated after an identification period. Optionally, in this case short-circuit/overload signals can be transmitted via separate 1-bit communication objects.

Short-circuit / overload detection is always active when a valve output is switched on (output energised) and always occurs in two output groups. Here, outputs 1 to 3 and outputs 4 to 6 each form a group. If there is an error, the actuator will only detect an overload / a short-circuit in a group at first. Therefore, the actuator then executes a special testing cycle, which guarantees safe detection of the valve outputs which are actually electrically overloaded. Only after overloaded or short-circuited valve outputs have been accurately determined is it possible to output overload/short-circuit signals to the bus. After error detection in a group, all the outputs in this group are immediately deactivated for 6 minutes (switch-off idle phase / outputs not energised). During this time, the error detection circuit resets thermally.

### Testing cycle

During the testing cycle, the actuator applies stepped, time-offset switch-on and deactivation of each valve output of the affected group to determine the outputs which are overloaded or shorted and which thus led to the error switch-off. In the case of a weak overload at, for example, one valve output, it may occur during the testing cycle that, during the individual testing of the output during the switch-on phase, no overload is detected, as the overload is too slight. This means that it may be necessary to start multiple testing cycles, until the overloaded output can be identified clearly. Each output group is equipped with a meter, which saves the number of testing cycles started for a group up to that point. Each time it is not possible to determine clearly if a valve output is overloaded or short-circuited during a testing cycle, then the counter will meter upwards by one increment. If another error is detected in an output group unsuccessfully tested for overload / short-circuit (meter reading > "0"), then the outputs will be energised with a longer switch-on time in the new testing cycle. In the first testing cycle, the switch-on time is 1 second, in the 2nd cycle 10 seconds, in the 3rd cycle 1 minute and, in the 4th cycle, 4 minutes. The meter reading is only saved in the device and cannot be read out.

If there is a collective overload, various weak overloads, possibly at multiple outputs, have collected into a stronger overall overload. If there is a collective overload, it may occur that, even after four testing cycles, no output can be clearly identified as overloaded. In this case, after the fourth cycle, the actuator will deactivate individual valve outputs of an output group, until no overload exists.

Here is the testing cycle for the identification of overloaded or short-circuited valve outputs in detail...

- 1.  
An overload or short-circuit was detected in a group. The actuator deactivates all the valve outputs of the affected group. The switch-off idle phase (6 minutes) is started.
- 2.  
The first valve output of the affected group (output 1 or output 4) switches on for approx. 1 second, if this output was not previously deactivated by a previous testing cycle. If the output was previously deactivated, then the actuator switches the next output on (output 2 or output 5, etc.).
  - 2. a  
If, during the switch-on time, no overload or no short-circuit is detected because the overload / the short-circuit is pending at another output or is too slight (weak overload), then the output will be switched off again. Continue with Step 3.
  - 2. b  
If, at the tested valve output, an overload or a short-circuit is detected, then a forced switch-off takes place immediately at this output. The output is deactivated. Then a switch-off idle phase of 6 minutes is started, during which the error detection circuit resets thermally. During this time, the affected output group remains completely switched off.
- 3.  
The output test started under Step 2 is continued with the next output, which has not been deactivated, in the appropriate group in the same fashion, with a time gap of approx. 4 seconds from output test to output test, until the last valve output of the group or both groups has been processed.
- 4.  
The testing cycle is then finally exited when all the valve outputs or both groups have been processed.
  - 4. a  
The valve outputs detected as overloaded or having shorted in the testing cycle of the group(s) now remain deactivated and cannot be switched on again until the reset. The testing cycle counter is deleted. All the unaffected valve outputs are again activated normally.
  - 4. b  
If, during the testing cycle, no output was detected as being overloaded or having shorted (probable weaker overload), then the testing cycle counter for this/these group(s) will count upwards, so that, in the next cycle, all the affected valve outputs are tested with an extended switch-on time, in order to detect weaker overloads.

Exception: If the previously executed testing operation was the 4th sequence in succession without any error detection, then the actuator will assume that this is a collective overload at multiple outputs. In this case, the actuator will automatically deactivate one output of the affected group (output 3 or output 6), according to the priority. In so doing, the testing cycle counter will be deleted as for regular identification of an error, and testing again occurs with a 1 s switch-on time in the next cycle. If 4 cycles again occur after this, without outputs being detected as overloaded or having shorted during the individual test, then the actuator will again assume a collective overload and will automatically permanently deactivate the next outputs of the group(s) (firstly output 2 and/or output 5, then, after four more cycles, output 1 and/or output 4).

- 5.  
All the valve outputs not deactivated in the testing cycles then continue to work normally.
- i** If possible, connect actuators for environments with increased fail-safety requirements to the outputs 1 and 4. During overload detection, these are switched off last, as described.
- i** Signal telegrams, if configured for a valve output in the ETS, are only generated for those valve outputs which were forcibly deactivated by priority in the testing cycle, after the detection of an error or a collective overload.
- i** The resetting of an overload or a short-circuit during a testing cycle is ignored.
- i** To give less weight to detected overloads caused by rare, extreme interference, such as strong electromagnetic coupling into the low-voltage network (lightning strike close by), the cycle counter is reduced by 1 after a period of 28 days without the detection of a further overload or a new short-circuit. This ensures that, after long periods of time, valve outputs are not simply switched off after the 4th cycle without identification of a clear overload or a short-circuit.
- i** A valve output switched off via the bus (output not energised) can also be energised during the overload or short-circuit detection phase for the period of time defined in the testing cycle.

A short-circuit or an overload influences the command value status of the valve outputs of an output group. Even at the beginning of a short-circuit / overload identification phase, the actuator will set the command value status, according to the valve direction of action, either to "OFF" / "0%" (for deenergised closed) or to "ON" / "100%" (for deenergised opened). This valve status remains intact during the entire length of the identification phase and for valve outputs identified as having short-circuited or being overloaded. Energisation phases during the testing cycles do not influence the command value status.

- i** The command value status contained in the combined valve status is not influenced by a short-circuit or an overload.

- i** A valve output affected by a short-circuit / overload (valve completely closed on deenergised closed or completely opened on deenergised opened) does not influence the evaluation of the calculation of the "Largest command value" or the heat requirement and pump control.

Examples of overload / short-circuit detection...

Example 1

Error case = Short-circuit at valve output 4.

A short-circuit generates a short-circuit/overload signal in output group A4...A6. This produces the following sequence...

Test time	Outputs						KNX message						Comment
	1	2	3	4	5	6	1	2	3	4	5	6	
6min	N	N	N	0	0	0	-	-	-	-	-	-	Overload only affects one group!
<1s	N	N	N	1	0	0	-	-	-	T	-	-	Check output 4 4 s later → Short-circuit
6min	N	N	N	0	0	0	-	-	-	-	-	-	Switch-off idle phase. Short-circuit message
1s	N	N	N	0	1	0	-	-	-	-	-	-	Check output 5 → No error
1s	N	N	N	0	0	1	-	-	-	-	-	-	Check output 6 4 s later → No error
---	N	N	N	0	N	N	-	-	-	-	-	-	Output 4 remain deactivated 4 s later! All the other outp. contin. to work "normally"!

Image 17: Short-circuit at valve output 4

- "0" Output not energised
- "1" Output energised
- "N" Normal operation of the valve output
- "T" Short-circuit / overload identified (signal telegram is cancelled if configured)

On next error detection in group 4-6: Test switch-on time: 10 s

Example 2

Error case = Weak overload at valve output 2.

The overload is so weak that a switch-on time of 1 second does not lead to error detection. In the case of a weak overload, it should be expected that the overload/short-circuit signal only affects the directly affected output group (here: Outputs 1 to 3). This produces the following sequence...

Test time	Outputs						KNX message						Comment
	1	2	3	4	5	6	1	2	3	4	5	6	
6min	0	0	0	N	N	N	-	-	-	-	-	-	Overload only affects one group!
1s	1	0	0	N	N	N	-	-	-	-	-	-	Check output 1 → No error
1s	0	1	0	N	N	N	-	-	-	-	-	-	Check output 2 4 s later → No error
1s	0	0	1	N	N	N	-	-	-	-	-	-	Check output 3 4 s later → No error
---	N	N	N	N	N	N	-	-	-	-	-	-	4 s later: All outputs working normally.

Image 18: Weak overload at valve output 2 / first testing cycle

On next error detection in group 1...3: Test switch-on time: 10 s

It should be expected that, in normal operation, an overload will again be detected in the previously affected output group...

Test time	Outputs						KNX message						Comment
	1	2	3	4	5	6	1	2	3	4	5	6	
6min	0	0	0	N	N	N	-	-	-	-	-	-	Overload only affects one group!
10s	1	0	0	N	N	N	-	-	-	-	-	-	Check output 5 → No error
<10s	0	1	0	N	N	N	-	T	-	-	-	-	Check output 2 4 s later → Overload
6min	0	0	0	N	N	N	-	-	-	-	-	-	Switch-off idle phase. Overload message
10s	0	0	1	N	N	N	-	-	-	-	-	-	Check output 3 4 s later → No error
---	N	0	N	N	N	N	-	-	-	-	-	-	Output 2 remain deactivated 4 s later! All the other outputs continue to work "normally"!

Image 19: Weak overload at valve output 2 / second testing cycle

On next error detection in group 1...3: Test switch-on time: 1 s

Example 3

Error = Total overload in output group "Output 1 to 3".

The overload of individual valve outputs is so weak that, during the testing cycles, no output can be clearly identified as overloaded or having shorted during a test switch-on time of 4 minutes. This produces the following sequence...

Test time	Outputs						KNX message						Comment
	1	2	3	4	5	6	1	2	3	4	5	6	
6min	0	0	0	N	N	N	-	-	-	-	-	-	Overload only affects one group!
1s	1	0	0	N	N	N	-	-	-	-	-	-	Check output 1 → No error
1s	0	1	0	N	N	N	-	-	-	-	-	-	Check output 2 4 s later → No error
1s	0	0	1	N	N	N	-	-	-	-	-	-	Check output 3 4 s later → No error
---	N	N	N	N	N	N	-	-	-	-	-	-	4 s later: All outputs working normally.

Image 20: Total overload in output group 1...3 / first testing cycle

On next error detection in group 1...3: Test switch-on time: 10 s

It should be expected that, in normal operation, an overload will again be detected in the previously affected output group...

Test time	Outputs						KNX message						Comment
	1	2	3	4	5	6	1	2	3	4	5	6	
6min	0	0	0	N	N	N	-	-	-	-	-	-	Overload only affects one group!
10s	1	0	0	N	N	N	-	-	-	-	-	-	Check output 1 → No error
10s	0	1	0	N	N	N	-	-	-	-	-	-	Check output 2 4 s later → No error
10s	0	0	1	N	N	N	-	-	-	-	-	-	Check output 3 4 s later → No error
---	N	N	N	N	N	N	-	-	-	-	-	-	4 s later: All outputs working normally.

Image 21: Total overload in output group 1...3 / second testing cycle

On next error detection in group 1...3: Test switch-on time: 1 min.

It should be expected that, in normal operation, an overload will again be detected in the previously affected output group...

Test time	Outputs						KNX message						Comment
	1	2	3	4	5	6	1	2	3	4	5	6	
6min	0	0	0	N	N	N	-	-	-	-	-	-	Overload only affects one group!
1min	1	0	0	N	N	N	-	-	-	-	-	-	Check output 1 → No error
1min	0	1	0	N	N	N	-	-	-	-	-	-	Check output 2 4 s later → No error
1min	0	0	1	N	N	N	-	-	-	-	-	-	Check output 3 4 s later → No error
---	N	N	N	N	N	N	-	-	-	-	-	-	4 s later: All outputs working normally.

Image 22: Total overload in output group 1...3 / third testing cycle

On next error detection in group 1...3: Test switch-on time: 4 min.

It should be expected that, in normal operation, an overload will again be detected in the previously affected output group...



Test time	Outputs						KNX message						Comment
	1	2	3	4	5	6	1	2	3	4	5	6	
6min	0	0	0	N	N	N	-	-	-	-	-	-	Overload only affects one group!
4min	1	0	0	N	N	N	-	-	-	-	-	-	Check output 1 → No error
4min	0	1	0	N	N	N	-	-	-	-	-	-	Check output 2 4 s later → No error
4min	0	0	1	N	N	N	-	-	-	-	-	-	Check output 3 4 s later → No error
---	N	N	0	N	N	N	-	-	T	-	-	-	4 s later: Output 3 is deactivated autom. according to the priority. All the other outputs continue to work "normally"!

Image 23: Total overload in output group 1...3 / fourth testing cycle

On next error detection in group 1-3: Test switch-on time: 1 s

### Short-circuit / overload signal telegrams

Signal telegrams, are only transmitted for the outputs which were deactivated by priority in the testing cycle, after the detection of an error or a collective overload. The precondition is that the signal telegram on the parameter page "VOx - General - Status" is enabled by the "Short-circuit / overload signal" parameter with the setting "yes". The telegram polarity of the status telegram can be configured.

An active short-circuit / overload signal remains intact after a device reset by bus voltage return. In this case as well, the short-circuit / overload signal must first be reset (see "Resetting a short-circuit / overload" below). If, before the bus voltage failure, no short-circuit and no overload was identified, then the actuator will first transmit a signal telegram "No short-circuit / no overload" after bus voltage return. Should, after bus/mains voltage return, a short-circuit or an overload occur, then the actuator will start a new identification phase.

After an ETS programming operation, short-circuit / overload signals are always deactivated. Here, in the case of shorted or overloaded valve outputs, the actuator will first perform an identification phase again, in order to detect faulty valve outputs.

- i** The object always transmits the current status after bus voltage return and an ETS programming operation after a delay, providing that a delay after bus voltage return has been configured on the parameter page "General - Valve outputs".
- i** The states "Short-circuit" and "Overload" are also fed back in the combined valve status .

### Resetting a short-circuit / overload

Valve outputs, identified as having shorted or being overloaded, are detected by the actuator. In this case, affected valve outputs can no longer be activated by any functions of the actuator. The cause of the error must be eliminated and the "Short-circuit / overload" state also be reset, so that the outputs can be activated again.

There are two alternative options for the recommissioning of one or more deactivated valve outputs...

- Global reset of all overload / short-circuit states:  
All the overload / short-circuit states of the actuator can be reset jointly. For this, the 1-bit communication object "Reset short-circuit / overload" is available, which can be enabled on the parameter page "Valve / pump", using the "Global reset of all 'Short-circuit / overload' signals?" parameter in the "Yes"



setting. As soon as the actuator receives a "1" telegram via this object, all the overload / short-circuit states will be reset immediately. The actuator then deactivates the overload / short-circuit state of each valve output and also retracts the overload / short-circuit signals. Should all or some of the valve outputs still be shorted or overloaded at this time, then a new identification phase will begin.

A "0" telegram to the "Reset short-circuit / overload" object produces no reaction.

- i** The global resetting of an overload or a short-circuit during a testing cycle is always ignored.
- Resetting by switching off the valve voltage supply:  
Overload / short-circuit states can be reset by switching off the valve voltage supply. The following procedure is required for this:
  - a) Switch-off of the valve voltage supply. After this, the actuator immediately transmits a signal telegram "Failure of operating voltage", provided that this function is globally enabled in the ETS and the bus voltage is still switched on. In addition, all the overload / short-circuit signals of the valve outputs are reset immediately. If, at this time, no bus voltage is switched on, then the actuator will reset the overload / short-circuit signals after the bus voltage is switched on again.
  - b) Elimination of the cause of the overload / short-circuit
  - c) Switch-on of the valve voltage supply. The valves can then be activated again normally. When the valve voltage supply is switched on, the actuator also retracts the "Failure of operating voltage" signal, provided that this function is globally enabled in the ETS.
  - d) Should all or some of the valve outputs still be shorted or overloaded after the return of the valve voltage supply, then a new identification phase will begin.
- i** Switching off the valve voltage during a testing cycle only causes a reset of existing overload / short-circuit signals. The testing cycle is not cancelled.

### 9.9.1 Short-circuit and overload detection parameters

Short-circuit / overload	Checkbox (yes / no)
<p>The actuator is able to detect an overload or a short-circuit at the valve outputs and, in consequence, to protect them against destruction. Outputs which have experienced a short-circuit or a constant load are deactivated after an identification period. In this case, a short-circuit or overload signal can be transmitted via a KNX communication object.</p> <p>In the "yes" setting, this parameter enables the object "Short-circuit / overload - Status".</p>	

Object polarity	<b>1 = short-circuit/overload / 0 = no short-circuit/overload</b> 0 = short-circuit / overload / 1 = no short-circuit / overload
When the object for short-circuit / overload messaging is enabled, the telegram polarity of the "Short-circuit / overload - Status" object is defined here.	

## 9.9.2 Objects for short-circuit and overload detection

Function overload / short-circuit identification

Object no.	Function	Name	Type	DPT	Flag
29, 44, 59, 74, 89, 104	Short-circuit / overload - Status	VO x - Output (x = 1...6)	1-bit	1,005	C, R, -, T, -
1-bit output object to signal an identified overload or a short-circuit at the affected valve output. The telegram polarity can be configured. The object always transmits the current status after bus voltage return and an ETS programming operation after a delay, providing that a delay after bus voltage return has been configured on the parameter page "General - Valve outputs".					

## 9.10 Valve rinsing

To prevent calcification or sticking of a valve which has not been activated for some time, the actuator has an automatic valve rinsing function. Valve rinsing can be executed cyclically or using a bus command, causing the activated valves to run through the full valve stroke for a preset period of time. During valve rinsing, the actuator activates a command value of 100% without interruption for the affected valve output for half of the configured "Valve rinsing time". For this, the valves open completely. After half the time, the actuator switches to a command value of 0%, causing the connected valves to close completely.

If necessary, the intelligent valve rinsing can be enabled. In so doing, cyclical rinsing using the full stroke is only executed when a defined minimum command value limiting value was not exceeded during actuator operation.

- i** During valve rinsing, the actuator executes the command values "1" (corresponds to "100%" - open completely) and "0" (corresponds to "0%" - close completely) for valve outputs configured with a command value limiting value for the data formats "Switching (1-bit)" or "Constant (1-byte)".
- i** The actuator takes the valve direction of action configured in the ETS into account in the electrical activation of the valve output.

At the end of valve rinsing, the actuator automatic sets the tracked command value according to the priority control Priorities for valve outputs.

- i** The actuator does not execute valve rinsing if a higher-priority function is active. Nonetheless, the actuator internally starts the rinse length, as soon as the device receives a command for valve rinsing (cyclically or via bus command).

If, during an active rinsing time, higher-priority functions are exited, then the actuator will execute the remaining residual time of the rinse function. If the rinsing time continues to elapse during a function with a higher priority, then there is no residual time. Thus, the actuator will not execute the previously started valve rinsing.

- i** If the bus control of individual valve outputs is disabled as part of a permanent manual operation, then the actuator will save the start commands of a valve rinsing operation in the background. In this case, the actuator will start the rinse time immediately after the lifting of the disabling function. If, after this, the manual operation is exited after the rinse time has started (and no other higher-priority functions are active), then the actuator will also execute valve rinsing actively.
- i** The actuator also executes valve rinsing by starting the rinse time, even if the valve voltage supply has been switched off. A bus voltage failure immediately interrupts an active rinsing operation. When the bus/mains voltage returns, a previously interrupted rinsing operation is not executed again.
- i** Valve rinsing influences the status feedback of the active command value.

Valve rinsing possesses a separate 1-bit status object. Optionally, this object can be used, for example, to display a KNX visualisation that valve rinsing is taking place (rinse operation time running). The status telegram can be used, for example, to disable a KNX room temperature controller for the length of the valve rinsing. Particularly in the case of long rinsing times, the disabling of the room temperature controller, possibly in combination with the disabling of the controller operation, can make a positive contribution to the suppression of the oscillation behaviour of the controller. The telegram polarity of the status object is fixed: "0" = Valve rinsing inactive, "1" = Valve rinsing active.

- i** The object transmits the current status after bus and mains voltage return and after an ETS programming operation without a delay.

### Enabling valve rinsing

Valve rinsing can only be used if it has been enabled in the ETS.

- Set the parameter "Valve rinsing" on the parameter page "VOx - Enabled functions" to "yes". Using the "Valve rinsing time" parameter on the parameter page "VOx - General - Valve rinsing", configure for how long the rinse function (100% -> 0%) is to be executed.

Valve rinsing is enabled. Additional parameters become visible in the ETS, presetting whether the valve rinsing is to be activated cyclically and / or with bus control.

- i** Set the length of the valve rinsing to the adjusting cycle time of the electro-thermal actuators in such a way that they open and close completely. This is usually guaranteed by configuring the rinsing length to double the adjusting cycle time.
- Set the "Valve rinsing" parameter to "no".

Valve rinsing is not available.

### Configuring cyclical valve rinsing

The actuator can perform valve rinsing cyclically, if necessary. When using the cyclical valve rinsing, a rinse operation can be started automatically after a configurable cycle time (1...26 weeks). Here too, the valve rinsing length configured in the ETS defines the time for the once-only, complete opening and closing of the activated valve drives. At the end of a rinsing operation, the actuator always restarts the cycle time.

Valve rinsing must be enabled and a valid rinsing time configured.

- Set the "Cyclical valve rinsing" parameter to "yes". In the case of the "Repeat all" parameter, configure how often valve rinsing is to be performed automatically.

Cyclical valve rinsing is enabled.

- Set the "Cyclical valve rinsing" parameter to "No".

Cyclical valve rinsing is completely disabled. Valve rinsing can only be started by the communication object (if enabled).

**i** Each ETS programming operation resets the cycle time. The first rinsing operation with cyclical valve rinsing takes place after an ETS programming operation after the first time cycle has elapsed.

If there is a bus voltage failure, the actuator saves the remaining residual time of the current time cycle. The residual cycle time is restarted after bus voltage return.

A bus voltage failure immediately interrupts an active rinsing operation. After bus voltage return, a previously interrupted rinsing operation is not executed again. The actuator then starts a new time cycle for cyclical valve rinsing.

Optionally, intelligent cyclical valve rinsing can be additionally activated. Here, valve rinsing is only executed repeatedly, if, in the current time cycle, a minimum command value limiting value, configurable in the ETS, was not exceeded. If the active command value exceeds the limiting value, then the actuator will stop the cycle time. The actuator only restarts the cycle time if, in the further course of the command value change, a command value of "0%" or "OFF" (completely closed) is set (see figure 24). This prevents valve rinsing if the valve has already run through a sufficiently defined stroke.

If, after exceeding the configured limiting value, the value was not completely closed at least once (command value "0%" or "OFF"), then no further cyclical valve rinsing will take place.

Use of the intelligent cyclical valve rinsing means that rinsing operations over the entire valve stroke are only then used when this is sensible and actually required. For example, in the summer months, the use of heating power is lower. In consequence, the valves are activated less frequently by command values, meaning that valve rinsing should be performed as anti-sticking protection. In the winter months, it is fre-

quent necessary to activate heating valves using normal command value telegrams. The intelligent valve rinsing ensures that no redundant valve rinsing is not performed in the winter. In the summer, the intelligent control performs valve rinsing cyclically.

- i** The cycle time is always started after an ETS programming operation. This also occurs when the active command value exceeds the configured limiting value after the download.
- i** The combination of intelligent valve rinsing with a command value limit with a minimum command value limiting value. If a minimum limiting value of the command value limit exists, then the active command value of the affected valve output is never "0%". In consequence, the actuator would never restart the cycle time as part of intelligent valve rinsing.

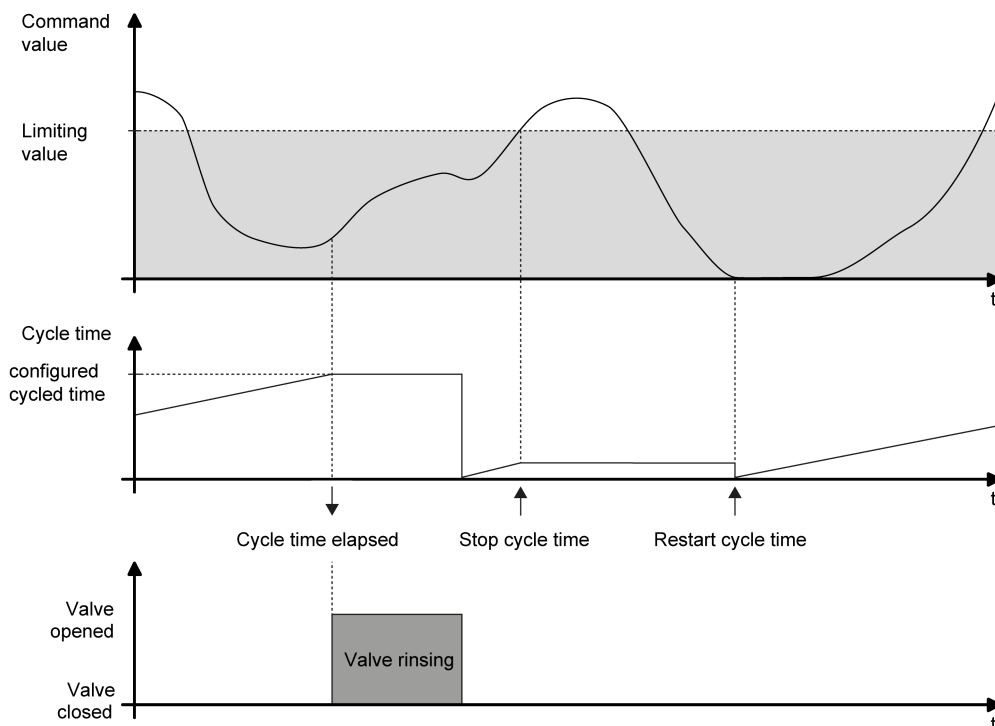

Image 24: Example of a minimum command value limiting value for intelligent valve rinsing

- Set the parameter "Take command values of last cycle time into account" to "yes". Define the command value limiting value via the parameter "Stop valve rinsing from command value of".

Intelligent cyclical valve rinsing is activated. Valve rinsing is only executed when the configured limiting value was exceeded at least once in the previous time cycle and, consequently, the valve was run to the "0%" command value.

- Set the parameter "Take command values of last cycle time into account" to "no".

Intelligent cyclical valve rinsing is deactivated. Valve rinsing always takes place as soon as the set cycle time has expired.

- i** Valve rinsing can optionally be started and, if required, stopped using a communication object. If valve rinsing was started by the object, then the actuator will stop the cycle time of the cyclical valve rinsing operation. The cycle time is only restarted after the rinsing operation has been fully executed without interruption or a stop command was received via the object.

### Configuring bus-controlled valve rinsing via an object

If necessary, valve rinsing can be started and, optionally, stopped using its own 1-bit communication object. This means that it is possible to activate a rinsing operation of the valve controlled by time or an event. It is also possible, for example, to cascade multiple heating actuators, so that they perform valve rinsing simultaneously (link of the individual status objects to the input objects of the valve rinsing).

Bus control can only be used if it has been enabled in the ETS.

Valve rinsing must be enabled and a valid rinsing time configured.

- Set the parameter "Valve rinsing controllable via object" to "yes". In the case of the parameter "Object polarity", configure the telegram polarity, thus presetting whether the bus-controlled starting and stopping, or, alternatively, only starting, is to be possible.

Bus-controlled valve rinsing is enabled. The communication object is visible. The name of the object is aligned to the setting of the permitted telegram polarity ("Start / stop valve rinsing" or "Start valve rinsing"). When a start command is received, the actuator immediately starts the configured time for a rinsing operation. The actuator also actively executes valve rinsing if no higher-priority function is active. If bus-controlled stopping is permitted, then the actuator will also react to stop commands by immediately interrupting running rinsing operations.

- Set the parameter "Valve rinsing controllable via object" to "no".

Bus-controlled valve rinsing is not available. Valve rinsing can only take place cyclically.

- i** Updates of the object from "Start" to "Start" or "Stop" to "Stop" do not produce a reaction. The length of an elapsing valve rinsing operation or the cycle time of a cyclical valve rinsing operation are not restarted by this.

- i** Bus-controlled valve rinsing via the object can be combined with a cyclical valve rinsing operation. If valve rinsing was started by the object, then the actuator will stop the cycle time of the cyclical valve rinsing operation. The cycle time is only restarted after the rinsing operation has been fully executed without interruption or a stop command was received via the object.

## 9.10.1 Valve rinsing parameters

Valve output x - General -> Enabled functions



Valve rinsing	Checkbox (yes / no)
<p>To prevent calcification or sticking of a valve which has not been activated for some time, the actuator has an automatic valve rinsing function. Valve rinsing can be executed cyclically or using a bus command, causing the activated valves to run through the full valve stroke for a preset period of time. During valve rinsing, the actuator activates a command value of 100% without interruption for half of the configured "Valve rinsing time". For this, the valves open completely. After half the time, the actuator switches to a command value of 0%, causing the connected valves to close completely.</p> <p>In the "Active" setting, this parameter enables valve rinsing.</p>	

"Valve output 1 - General -> Valve rinsing" configured.

Length of valve rinsing	1...5...59 min
<p>Here, preset for how long the rinse function (100% -&gt; 0%) is to be executed. Set the length of the valve rinsing to the adjusting cycle time of the electrothermal actuators in such a way that they open and close completely. This is usually guaranteed by configuring the rinsing length to double the adjusting cycle time.</p>	

Cyclical valve rinsing	Checkbox (yes / no)
<p>The actuator can perform valve rinsing cyclically, if necessary. When using the cyclical valve rinsing, a rinse operation can be started automatically after a configurable cycle time (1...26 weeks). Here too, the valve rinsing length configured in the ETS defines the time for the once-only, complete opening and closing of the activated valve drives. At the end of a rinsing operation, the actuator always restarts the cycle time.</p> <p>Yes: Cyclical valve rinsing is enabled. Each ETS programming operation resets the cycle time. The first rinsing operation with cyclical valve rinsing takes place after an ETS programming operation after the first time cycle has elapsed. If there is a power failure, the actuator saves the remaining residual time of the current time cycle. The residual cycle time is restarted after mains voltage return. A power failure immediately interrupts an active rinsing operation. After mains voltage return, a previously interrupted rinsing operation is not executed again. The actuator then starts a new time cycle for cyclical valve rinsing.</p> <p>No: Cyclical valve rinsing is completely disabled. Valve rinsing can only be started by the communication object (if enabled).</p>	

Repeat all	1...26 week(s)
<p>This parameter defines how often cyclical valve rinsing is to be performed automatically.</p>	



Take command values of last cycle time into account	Checkbox (yes / no)
<p>Optionally, intelligent cyclical valve rinsing can be additionally activated here. Here, valve rinsing is only executed repeatedly, if, in the current time cycle, a configured minimum command value limiting value was not exceeded. If the active command value exceeds the limiting value, then the actuator will stop the cycle time. The actuator only restarts the cycle time if, in the further course of the command value change, a command value of "0%" or "OFF" (completely closed) is set. This prevents valve rinsing if the valve has already run through a sufficiently defined stroke. If, after exceeding the configured limiting value, the value was not completely closed at least once (command value "0%" or "OFF"), then no further cyclical valve rinsing will take place.</p>	
Stop valve rinsing from command value of	10...50...100 %
<p>This parameter defines the minimum command value limiting value of the intelligent valve rinsing. Intelligent valve rinsing is only executed repeatedly, if, in the current time cycle, a minimum command value limiting value configured here was not exceeded. If the active command value exceeds the limiting value, then the actuator will stop the cycle time.</p>	
Valve rinsing controllable via object	Checkbox (yes / no)
<p>If necessary, valve rinsing can be started and, optionally, stopped using its own 1-bit communication object. This means that it is possible to activate a rinsing operation of the valve controlled by time or an event. It is also possible, for example, to cascade multiple heating actuators, so that they perform valve rinsing simultaneously (link of the individual status objects to the input objects of the valve rinsing). Bus control can only be used if it has been enabled here.</p>	
Object polarity	<b>1 = start / 0 = stop</b> 1 = stop / 0 = start 1 = start (stop not possible) / 0 = ---
<p>This parameter sets the telegram polarity of the object for external valve rinsing. The name of the object is aligned to the setting of the permitted telegram polarity ("Start / stop valve rinsing" or "Start valve rinsing"). When a start command is received, the actuator immediately starts the configured time for a rinsing operation. The actuator also actively executes valve rinsing if no higher-priority function is active. If bus-controlled stopping is permitted, then the actuator will also react to stop commands by immediately interrupting running rinsing operations.</p>	

## 9.10.2 Objects for valve rinsing

Function: Valve rinsing

Object no.	Function	Name	Type	DPT	Flag
27, 42, 57, 72, 87, 102	Valve rinsing - Start Valve rinsing - Start / Stop	VOx - Input (x = 1...6)	1-bit	1,003	C, (R), W, -, -

1-bit input object for starting and stopping valve rinsing. Valve rinsing can be activated by time or an event using this object. It is also possible, for example, to cascade multiple heating actuators, so that they perform valve rinsing simultaneously (link of the individual status objects to the input objects of the valve rinsing).

The telegram polarity can be configured. Stopping can be prevented via the object as an option.

The time of cyclical valve rinsing is restarted as soon as an externally started valve rinsing operation is stopped by a Stop telegram or by the expiry of the rinsing time. Updates of the object from "Start" to "Start" or "Stop" to "Stop" do not produce a reaction. The length of an elapsing valve rinsing operation or the cycle time of the cyclical valve rinsing are not restarted by this.

Object no.	Function	Name	Type	DPT	Flag
28, 43, 58, 73, 88, 103	Valve rinsing - Status	VO x - Output (x = 1...6)	1-bit	1,002	C, R, -, T, -

1-bit output object for status feedback of a valve rinsing operation. The telegram polarity is fixed: "0" = Valve rinsing inactive, "1" = Valve rinsing active.

The object transmits the current status after bus and mains voltage return and after an ETS programming operation without a delay.

## 9.11 Operating hours counter

The operating hours counter determines the switch-on time of a valve output. For the operating hours counter, an output is actively on, when it is energised, i.e. when the status LED on the front panel of the device. As a result, the operating hours counter determines the time during which deenergised closed valves are opened or deenergised opened valves are closed.

The operating hours counter can either be configured as a second counter or alternatively as an hour counter.

- Second counter

The actuator adds up the determined switch-on time accurately to the second for an energised output. The totalled operating seconds are added in a 4-byte counter and stored permanently in the device. The current meter reading can be transmitted cyclically to the KNX by the "Operating hours counter - Meter reading - Status" communication object or when there is a change in an interval value in accordance with DPT 13.100.

- Hour counter

The actuator adds up the determined switch-on time accurately to the minute for an energised output in full operating hours (see figure 25). The totalled operating hours are added in a 2-byte meter and stored permanently in the device. The current meter reading can be transmitted cyclically to the KNX by the "Operating hours counter - Meter reading - Status" communication object or when there is a change in an interval value in accordance with DPT 7.007.

- i** During pulse width modulation (PWM) at a valve output, the operating hours counter only evaluates the switch-on time of the PWM signal.

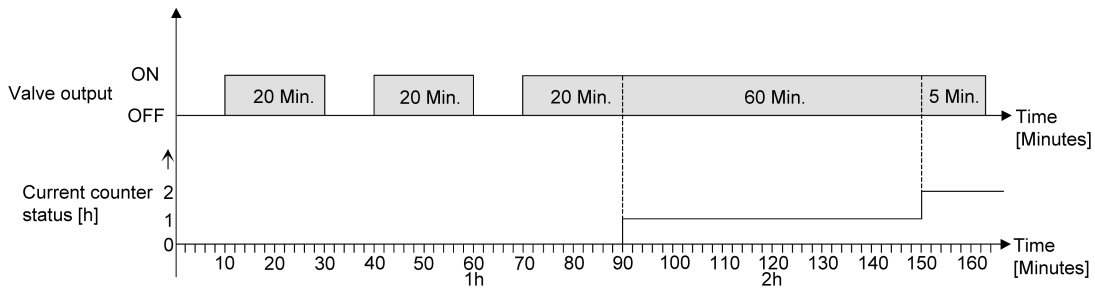

Image 25: Function of the operating hours counter (using the example of an up-counter)

In the as-delivered state, the operating hour values of all valve outputs of the actuator is "0". If the operating hours counter is not enabled in the configuration of an output, no operating hours will be counted for the valve concerned. Once the operating hours counter is enabled, however, the operating hours will be determined and added up by the ETS immediately after commissioning the actuator.

If the operating hours counter is subsequently disabled again in the parameters and the actuator is programmed with this disabling function, all the operating hours previously counted for the valve output concerned will be deleted. When enabled again, the meter reading of the operating hours counter is always on "0 h".

The operating hours values (full hours) or operating seconds stored in the device will not be lost in case of a bus voltage failure or by ETS programming.

On the hour counter: Any summed up operating minutes (full hour not yet reached) will be rejected in this case, however.

After bus voltage return or after an ETS programming operation, the actuator passively updates the "Value operating hours counter" communication object in each output. The object value can be read out if the read-flag is set. The object value, depending on the configuration for the automatic transmission, is actively transmitted if necessary to the KNX once the configured transmission delay has elapsed after bus voltage return (see "Set transmission behaviour of the operating hours counter").

The operating hours counter detects any operation of the valve outputs in manual operation, which means that switching on an output also activates a counting operation and the manual switch-off interrupts a counting operation.

No operating hours are counted if the supply voltage of the valves is not switched on.

### Activating the operating hours counter

The operating hours counter only counts the operating hours of a valve output if it was activated in the ETS.

- Set the parameter "Operating hours counter" on the parameter page "VOx - General -> Enabled functions" to "yes".  
The operating hours counter is activated.
- Set the parameter "Operating hours counter" on the parameter page "VOx - General -> Enabled functions" to "no".

The operating hours counter is deactivated.

- i** Deactivation of the operating hours counter and subsequent programming with the ETS resets the counter status to "0".

### Setting type of counter of the operating hours counter

The operating hours counter can optionally be configured as an up-counter or down-counter. Depending on this type of counter, a limit or start value can be set optionally, whereby, for example, the operating time of an actuator can be monitored by restricting the counter range.

#### Up-counter:

After activating the operating hours counter by enabling in the ETS or by restarting, the operating hours are counted starting at "0". A maximum of 65,535 hours or 2147483647 can be counted (corresponds to approx. 66 years), after that the counter stops and signals a counter operation via the "Operating hours count. elapsed" object.

A limiting value can be set optionally in the ETS or can be predefined via the communication object "Limiting value operating hours counter". In this case, the counter operation is signalled to the bus via the "Operating hours count. elapsed" object if the limiting value is reached, but the meter continues counting - if it is not restarted - up to the maximum value 65535 and then stops. Only a restart initiates a new counting operation.

#### Down-counter:

After enabling the operating hours counter in the ETS, the meter reading is on "0 h" and the actuator signals a counter operation for the output concerned after the programming operation or after bus voltage return via the "Operating hours count. elapsed" object. Only after a restart is the down-counter set to the maximum value of 65,535 hours or 2147483647 seconds (corresponds to approx. 66 years) and the counter operation is started.

A start value can be set optionally in the ETS or can be predefined via the communication object "start value operating hours counter". If a start value is set, the down-counter is initialised with this value instead of the maximum value after a restart. The meter then counts the start value downwards by the hour. When the down-counter reaches the value "0", the counter operation is signalled to the bus via the "Operating hours count. elapsed" and the counting is stopped. Only a restart initiates a new counting operation.

The use of the operating hours counter must be set on the parameter page "Ax – Operating hours counter".

- Set the parameter "Counting direction" to "Forward". Set the parameter "Specify signal value" to "via parameter" or "via object" if it is necessary to monitor the limiting value. Otherwise, reset the parameter to "no". In the "via parameter" setting, configure the required limit value (1 ... 2147483647 s or 1 ... 65535 h).

The meter counts the operating hours forwards starting from "0 h". If the monitoring of the limiting value is activated, the actuator transmits a "1" telegram via the object "Operating hours count. elapsed" for the valve output concerned once the predefined limiting value is reached. Otherwise, the counter operation is first transmitted when the maximum value is reached.

- Set the parameter "Counting direction" to "Backward". Set the parameter "Specify start value" to "via parameter" or "via object" if it is necessary to specify a start value. Otherwise, reset the parameter to "no". In the "via parameter" setting, configure the required start value (1 ... 2147483647 s or 1 ... 65535 h).

The meter counts the operating hours down to "0 h" after a restart. With a start value preset, the start value is counted down, otherwise the counting operation starts at the maximum value. The actuator transmits a "1" telegram via the object "Operating hours count. elapsed" for the valve output concerned once the value "0" is reached.

- i** The value of the communication object "Operating hours counter - Counter elapsed - Status" is permanently stored internally. The object is initialised immediately with the value that was saved before bus voltage return or ETS programming. If an operating hours counter is in this case identified as having elapsed, i.e. if the object value is a "1", an additional telegram will be actively transmitted to the bus. If the counter has not yet elapsed (object value "0"), no telegram is transmitted on bus voltage return or after an ETS programming operation.
- i** With a signal value or start value preset via object: The values received via the object are first validly accepted and permanently saved internally after a restart of the operating hours counter. The object is initialised immediately with the value that was last saved before bus voltage return or ETS programming. The values received will be lost in the case of a bus voltage failure or by an ETS download if no counter restart was executed before. For this reason, when specifying a new start or limiting value it is advisable to always execute a counter restart afterwards as well.  
A standard value is predefined provided that no signal value or start value has been received yet via the object. The values received and stored via the object are reset to the standard value if the operating hours counter is disabled in the parameters of the ETS and a ETS download is being performed.
- i** With a signal value or start value predefined via object: If the signal value or start value is predefined with "0", the actuator will ignore a counter restart to avoid an undesired reset (e.g. in construction site mode -> hours already counted by manual operation).
- i** If the counter direction of an operating hours counter is reversed by reconfiguration in the ETS, a restart of the meter should always be performed after programming the actuator so that the meter is reinitialised.

## Restarting the operating hours counter

The meter reading of the operating hours can be reset at any time by the communication object "Operating hours counter - Restart". The polarity of the reset telegram is predefined: "1" = Restart / "0" = No reaction.

- Write "1" to the communication object "Operating hours counter - Restart".  
 In the up-counter the meter is initialised with the value "0" after a restart and in the down-counter initialised with the start value. If no start value was configured or predefined by the object, the start value is preset to 65,535 hours or 2147483647 seconds.  
 During every counter restart, the initialised meter reading is transmitted actively to the bus. After a restart, the signal of a counter operation is also reset. At the same time, a "0" telegram is transmitted to the bus via the object "Operating hours count. elapsed".  
 In addition, the limiting or start value is initialised.
- ⓘ If a new limiting or start value was predefined via the communication object, a counter restart should always be performed afterwards, too. Otherwise, the values received will be lost in the case of a bus voltage failure or by an ETS download.
- ⓘ If a start or limiting value is predefined with "0", there are different behaviours after a restart, depending on the principle of the value definition...  
 Preset as parameter:  
 The counter elapses immediately after a counter restart.  
 Preset via object:  
 A counter restart will be ignored to avoid an undesired reset (e.g. after installation of the devices with hours already being counted by manual operation). A limiting or start value greater than "0" must be predefined in order to perform the restart.

## Transmission behaviour of the operating hours counter

The current value of the operating hours counter is always tracked in the communication object "Operating hours counter - Meter reading - Status". After bus voltage return or after an ETS download, the actuator passively updates the "Operating hours counter - Meter reading - Status" communication object in each valve output. The object value can be read out if the read-flag is set.

In addition, the transmission behaviour of this communication object can be set.

The use of the operating hours counter must be set on the parameter page "VOx – General -> Enabled functions".

- Set the parameter "Transmission behaviour" to "on change by interval value". Set the parameter "Counting interval" to the desired value.  
 The meter reading is transmitted to the bus as soon as it changes by the predefined counting value interval. After bus voltage return or after an ETS programming operation, the object value is automatically transmitted immediately if the current meter reading corresponds to the counting interval or a multiple thereof. A meter reading "0" is always transmitted in this case.



- Set the parameter "Transmission behaviour" to "cyclical".  
 The counter value is transmitted cyclically. The cycle time is defined on the parameter page "General valve outputs". After bus voltage return or ETS programming, the meter reading is transmitted to the KNX after the configured cycle time has elapsed.

### 9.11.1 Operating hours counter parameters

Valve outputs - General valve outputs - VOx General - Enabled functions

Operating hours counter	Checkbox (yes / no)
<p>The operating hours counter can be enabled here. The operating hours counter determines the switch-on time of a valve output. For the operating hours counter, an output is actively on, when it is energised, i.e. when the status LED on the front panel of the device. As a result, the operating hours counter determines the time during which deenergised closed valves are opened or deenergised opened valves are closed.</p> <p>If the operating hours counter is not enabled, no operating hours will be counted for the valve output concerned. Once the operating hours counter is enabled, however, the operating hours will be determined and added up by the ETS immediately after commissioning the actuator.</p> <p>If the operating hours counter is subsequently disabled again in the parameters and the actuator is programmed with this disabling function, all operating hours previously counted will be deleted. When enabled again, the meter reading of the operating hours counter is always on "0 h".</p>	

Valve outputs - General valve outputs - VOx General - Operating hours counter

Counting method	Seconds
	Hours
<p>The operating hours counter can either be configured as a second counter or alternatively as an hour counter.</p> <p>Second counter: The actuator adds up the determined switch-on time accurately to the second for a switched-on valve output. The totaled operating seconds are added in a 4-byte counter and stored permanently in the device. The current meter reading can be transmitted cyclically to the KNX by the "Operating hours counter - Meter reading - Status" communication object or when there is a change in an interval value in accordance with DPT 13.100.</p> <p>Hour counter: The actuator adds up the determined switch-on time accurately to the minute for a switched-on valve output in full operating hours. The totaled operating hours are added in a 2-byte meter and stored permanently in the device. The current meter reading can be transmitted cyclically to the KNX by the "Operating hours counter - Meter reading - Status" communication object or when there is a change in an interval value in accordance with DPT 7.007.</p>	



Counting direction	Forward Backward
The operating hours counter can be configured as an up-counter or down-counter. The setting here influences the visibility of the other parameters and objects of the operating hours counter.	
Specify signal value	Checkbox (yes / no)
If the up-counter is used, a signal value can optionally be predefined. The "No" setting deactivates the limiting value. This parameter is only visible in the "Up-counter" counter type.	
Preset value	via parameter via object
This parameter defines whether the signal value can be set via a separate parameter or adapted individually by a communication object from the bus. This parameter is only visible in the "Up-counter" counter type.	
Signal value	0... <b>2147483647</b> * 0... <b>65535</b> **
The limiting value of the up-counter is set here. Once the limiting value is reached, an "ON" telegram is transmitted via the object "Operating hours counter - Counter elapsed". The counter itself continues until the maximum counter status is reached and then stops. *: With second counter **: With hour counter This parameter is only visible if the parameter "Preset value" is set to "via parameter".	
Specify start value	Checkbox (yes / no)
If the down-counter is used, a start value can optionally be predefined. This parameter defines whether the start value can be set via a separate parameter or adapted individually by a communication object from the bus. The setting "No" deactivates the start value. This parameter is only visible in the "Down-counter" counter type.	
Preset value	via parameter via object
This parameter defines whether the signal value can be set via a separate parameter or adapted individually by a communication object from the bus. This parameter is only visible in the "Up-counter" counter type.	

Start value	0...2147483647* 0...65535**
<p>The start value of the down-counter is set here.</p> <p>*: With second counter **: With hour counter</p> <p>This parameter is only visible in the "Down-counter" counter type and then only if the parameter "Preset value" is set to "via parameter".</p>	
Cycle time	0...23 h 0...15...59 min 0...59 s
<p>This parameter defines the cycle time for the cyclical transmission. Setting the cycle time hours, minutes and seconds.</p>	
Counting interval	0...3600...2147483647 s * 0...1...65535 h **
<p>The interval of the counter value is set here for automatic transmission. The current meter reading is transmitted to the KNX after the interval configured here.</p> <p>*: With second counter **: With hour counter</p> <p>This parameter is only visible if the parameter "Transmission behaviour" is set to "on change by interval value".</p>	

### 9.11.2 Objects for operating hours counter

Object no.	Function	Name	Type	DPT	Flag
112, 119, 126, 133, 140, 147	Operating hours counter - Restart	VO x ... - Input	1-bit	1,015	C, (R), W, -, A
<p>1-bit object for resetting the operating hours counter of a valve output ("1" = Restart, "0" = No reaction).</p>					
Object no.	Function	Name	Type	DPT	Flag
113, 120, 127, 134, 141, 148	Operating hours counter - Meter reading - Status	VO x ... - Output	4 bytes	13,100	C, (R), -, T, A
<p>4-byte object to transmit or read out the current counter level of the operating hours counter of a valve output.</p> <p>Value range: 0...2147483647 seconds</p> <p>If the bus voltage should fail, the value of the communication object is not lost and is actively transmitted to the bus after bus voltage return or an ETS programming operation. In the as-delivered state, the value is "0".</p> <p>This object is only available with the second counter.</p>					

Object no.	Function	Name	Type	DPT	Flag
114, 121, 128, 135, 142, 149	Operating hours counter - Meter reading - Status	VO x ... - Output	2 bytes	7,007	C, (R), -, T, A
<p>2-byte object to transmit or read out the current counter level of the operating hours counter of a valve output. Value range: 0...65,535 hours</p> <p>If the bus voltage should fail, the value of the communication object is not lost and is actively transmitted to the bus after bus voltage return or an ETS programming operation. In the as-delivered state, the value is "0".</p> <p>This object is only available with the hour counter.</p>					

Object no.	Function	Name	Type	DPT	Flag
115, 122, 129, 136, 143, 150	Operating hours counter - Counter elapsed	VO x ... - Output	1-bit	1,002	C, (R), -, T, A
<p>1-bit object to sign that the operating hours counter has elapsed (forwards counter = signal value reached / backwards counter = value "0" reached). With a message, the object value is actively transmitted to the KNX ("1" = message active / "0" = message inactive).</p> <p>If the bus voltage should fail, the value of the communication object is not lost and is actively transmitted to the bus after bus voltage return or an ETS programming operation.</p>					

Object no.	Function	Name	Type	DPT	Flag
110, 117, 124, 131, 138, 145	Operating hours counter - Signal value / Start value	VO x ... - Input	4 bytes	13,100	C, (R), W, -, A
<p>4-byte object for external presetting of a signal value / start value of the operating hours counter of a valve output. Value range: 0...2147483647 seconds</p> <p>This object is only available with the second counter.</p>					

Object no.	Function	Name	Type	DPT	Flag
111, 118, 125, 132, 139, 146	Operating hours counter - Signal value / Start value	VO x ... - Input	2 bytes	7,007	C, (R), W, -, A
<p>2-byte object for external presetting of a signal value / start value of the operating hours counter of a valve output. Value range: 0...65,535 hours</p> <p>This object is only available with the hour counter.</p>					

## 10 Room temperature controller

There are 12 controllers integrated into the device's software that can be used for individual room temperature control. This allows the temperature to be set in up to 12 rooms or room areas to specified setpoints through independent control processes. The command value outputs of these controllers can be linked to the electronic valve outputs of the actuator, meaning that temperature control and valve activation can take place using just one bus device, if required. The use of external room temperature controllers (e.g. push-button sensors with RTC) is thus not absolutely essential, but is possible as the valve outputs can also be activated individually via the KNX. The integrated controllers can also transmit command value telegrams to the KNX and thus activate other heating actuators or fan coil actuators.

The integrated controllers of the device always work as the main controller. All the controller functions (e.g. setpoint temperature specification, operating mode switchover, switchover of the operating mode) are controlled via KNX communication objects (object controller without its own operating elements), meaning that controller operation is possible via controller extensions or visualisations. The room temperature is made available to the integrated controllers via separate communication objects.

### 10.1 Channel configuration

To simplify project design, all room temperature controllers can be activated or deactivated individually in the ETS. Parameters and communication objects of the deactivated channels are hidden.

To simplify further, the room temperature controllers can be assigned to the same parameters and thus configured identically. The parameter "Parameterisation" stipulates whether every room temperature controller of the device can be configured individually or whether the parameters of room temperature controller 1 are to be applied.

With the setting "like RTC 1", the parameter pages in the ETS are reduced. The visible parameters of the first room temperature controller are then automatically also used on this room temperature controller. Only the communication objects can then be configured separately for the controllers. This setting should be selected, for example, if all room temperature controllers behave identically and should only be activated by different group addresses (e.g. in office blocks or in hotel rooms).

In the parameter setting "individually", each room temperature controller possesses its own parameter pages in the ETS.

#### 10.1.1 Channel configuration parameters

General -> Parameterisation

RTC x (x = 1 ... 12) Use	Checkbox (yes / no)
Room temperature controllers that are not required can be activated or deactivated. If the following parameter "Configuration" is set to "like RTC 1" for one of the following valve outputs, room temperature controller 1 must be activated.	

RTC x (x = 1 ... 12) Parameterisation	individually / like RTC 1
To simplify the configuration, all the room temperature controllers can be assigned to the same parameters in the ETS and thus configured identically. This parameter stipulates whether a room temperature controller of the device can be configured individually or whether the parameters of room temperature controller 1 are to be applied.	
For room temperature controller 1, the parameter is permanently set to "individually".	

## 10.2 Room temperature controller - General

### 10.2.1 Name

Optional names can be assigned for each room temperature controller. The names should clarify the use of the output (e.g. "heating living room" or "cooling ceiling office 1"). The names are only used in the ETS in the text of the parameter pages and communication objects.

### 10.2.2 Operating mode

#### Introduction

A room temperature controller distinguishes between two different operating modes. The operating modes specify whether you want the controller to use its command value to trigger heating systems ("heating" single operating mode) or cooling systems ("cooling" single operating mode). You can also activate mixed operation, with the controller being capable of changing over between "Heating" and "Cooling" either automatically or, alternatively, controlled by a communication object.

In addition, you can establish two-level control operation to control an additional heating or cooling unit. For two-level feedback control, separate command values will be calculated as a function of the temperature deviation between the setpoint and the actual value for the basic and additional levels. Parameter "Operating mode" in the parameter branch "Room temperature controller -> RTCx - General" sets the operating mode and, if necessary, enables the additional level(s).

#### "Heating" or "cooling" single operating modes

In the single "Heating" or "Cooling" operating modes without any additional level, the controller will always work with one command value. Alternatively, when the additional level is enabled, it will use two command values in the configured operating mode. Depending on the room temperature determined and on the specified setpoint

temperatures of the operating modes, the room temperature controller will automatically decide whether heating or cooling energy is required and calculates the command value for the heating or cooling system.

### **"Heating and cooling" mixed operating mode**

In the "Heating and cooling" mixed operating mode, the controller is capable of triggering heating and cooling systems. In this connection, you can set the change-over behaviour of the operating modes...

- Parameter "Heating/cooling switchover" in the parameter branch "Room temperature controller -> RTCx - General" set to "automatic via RTC".  
In this case, a heating or cooling mode is automatically activated, depending on the determined room temperature and on the specified setpoint temperature. If the room temperature is within the preset deadband neither heating nor cooling will take place (both command values = "0"). The communication object "Setpoint temperature" displays the most recently active setpoint temperature for heating or cooling. If the room temperature is higher than the cooling setpoint temperature, cooling will take place. If the room temperature is higher than the heating setpoint temperature, heating will take place.  
When the operating mode is changed over automatically, the information can be actively sent to the bus via the object "Operating mode - Status" to indicate whether the controller is working in the heating mode ("1" telegram) or in the cooling mode ("0" telegram). In this case, a telegram will be transmitted immediately on changing from heating to cooling (object value = "0") or from cooling to heating (object value = "1"), respectively.  
The "Cyclical transmission" parameter enables cyclical transmission (factor setting > "0 min") and specifies the cycle time.  
With an automatic operating mode change-over, it should be noted that under certain circumstances there will be continuous change-over between heating and cooling if the deadband is too small. For this reason, you should, if possible, not set the deadband (temperature difference between the setpoint temperatures for the comfort heating and cooling modes) below the default value (2 K).
- Parameter "Heating/cooling switchover" in the parameter branch "Room temperature controller x -> RTCx - General" set to "via object".  
In this case, the operating mode is controlled via the "Operating mode" object, irrespective of the deadband. This type of change-over can, for example, become necessary if both heating and cooling should be carried out through a one-pipe system (heating and cooling system). For this, the temperature of the medium in the single-pipe system must be changed via the system control. Afterwards the heating/cooling operating mode is set via the object (often the single-pipe system uses cold water for cooling during the summer, hot water for heating during the winter).  
The "Operating mode" object has the following polarities: "1": heating; "0": cooling. After a reset, the object value will be "0", and the "Operating mode after reset" set in the ETS will be activated. The parameter "Operating mode after reset" can be used to determine which operating mode is activated after a reset. For the "Heating" or "Cooling" settings, the controller will activate the

configured heating/cooling operating mode immediately after the initialisation phase. In case of parameterisation "Operating mode before reset" the operating mode which was selected before the reset will be activated.

- i** Setpoint temperatures can be specified for each operating mode in the ETS as part of configuration. It is possible to configure the setpoints for the "Comfort", "Standby" and "Night" modes directly (absolute setpoint presetting) or relatively (derivation from basic setpoint). With absolute setpoint presetting there is no basic setpoint and also no deadband in the mixed operating mode "Heating and cooling" (if necessary also with additional level). Consequently, the room temperature controller cannot control the switchover of the operating mode automatically, which is why, in this configuration, the setting for the parameter "Heating/cooling switchover" is fixed in the ETS to "via object".

### 10.2.3 Type of control

#### Introduction

To facilitate convenient temperature control in living or business spaces a specific control algorithm which controls the installed heating or cooling systems is required. Taking account of the preset temperature setpoints and the actual room temperature, the controller thus determines command values which trigger the heating or the cooling system. The control system (control circuit) consists of a room temperature controller, a valve drive or an actuator with switching output signals (e.g. heating actuator when ETD electrothermal drives are used), the actual heating or cooling element (e.g. radiator or cooling ceiling) and of the room. This results in a controlled system (see figure 26).

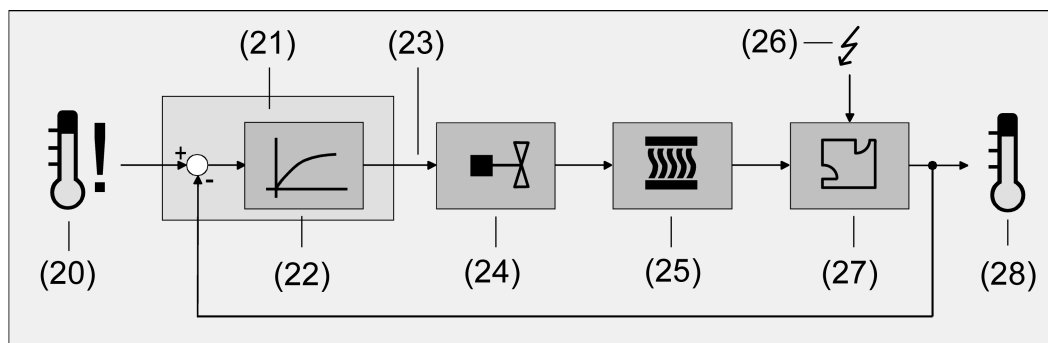

Image 26: Controlled system of single-room temperature control

- (20) Setpoint temperature specification
- (21) Room temperature controller
- (22) Control algorithm
- (23) Command value
- (24) Valve control (valve drive, ETD, heating actuator, ...)
- (25) Heat / cold exchanger (radiator, cooling ceiling, FanCoil, ...)
- (26) Fault variable (sunlight penetration, outdoor temperature, illumination systems, ...)
- (27) Room



## (28) Actual temperature (room temperature)

The controller evaluates the actual temperature (28) and compares it with the specified setpoint temperature (20). With the aid of the selected control algorithm (22), the command value (23) is then calculated from the difference between the actual and the setpoint temperature. The command value controls valves or fans for heating or cooling systems (24), meaning that heating or cooling energy in the heat or cold exchangers (25) is passed into the room (27). Regular readjustment of the command value means that the controller is able to compensate for setpoint / actual temperature differences caused by external influences (26) in the control circuit. In addition, the flow temperature of the heating or cooling circuit influences the control system which necessitates adaptations of the variable.

The room temperature controller facilitates either proportional/integral (PI) feedback control as a continuously working or switching option, or, alternatively, switching 2-point feedback control. In some practical cases, it can become necessary to use more than one control algorithm. For example, in bigger systems using floor heating, one control circuit which solely triggers the floor heating can be used to keep the latter at a constant temperature. The radiators on the wall, and possibly even in a side area of the room, will be controlled separately by an additional level with its own control algorithm. In such cases, distinction must be made between the different types of control, as floor heating systems, in most cases, require control parameters which are different to those of radiators on the wall, for example. It is possible to configure up to four independent control algorithms in two-level heating and cooling operation.

The command values calculated by the control algorithm are output via the "Heating command value" or "Cooling command value" communication objects. Depending on the control algorithm selected for the heating and/or cooling mode, the format of the command value objects is, among other things, also specified. In this way, 1-bit or 1-byte command value objects can be created. The control algorithm is specified by the parameters "Type of heating control" or "Type of cooling control" in the "Room temperature control -> RTCx - General" parameter branch and, if necessary, also with a distinction of the basic and additional stages.

### **Continuous PI control**

PI control is an algorithm which consists of a proportional part and an integral part. Through the combination of these control properties, you can obtain room temperature control as quickly and precisely as possible without or only with low deviations. When you use this algorithm, the room temperature controller will calculate a new continuous command value in cycles of 30 seconds and transmit it to the bus via a 1-byte value object if the calculated command value has changed by a specified percentage. The parameter "on change by (0 = inactive)" in the parameter branch "Room temperature controller -> RTCx - General -> Command value output" specifies the change interval in percent.

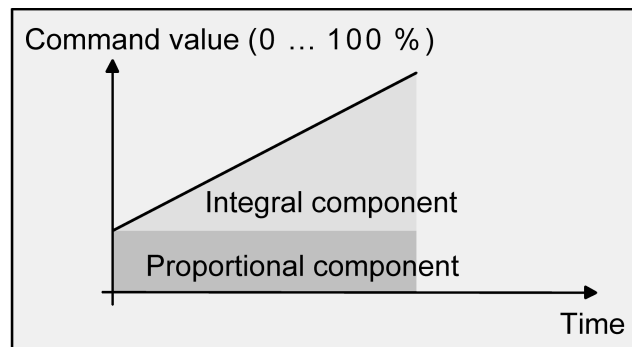

Image 27: Continuous PI control

An additional heating or cooling level as PI control works in the same way as the PI control of the basic level, with the exception that the setpoint will shift, taking account of the configured level width.

### Switching PI control

With this type of feedback control, the room temperature will also be kept constant by the PI control algorithm. Taking the mean value for a given time, the same behaviour of the control system will result as you would obtain with a continuous controller. The difference compared with continuous feedback control is only the way how the command value is output. The command value calculated by the algorithm in cycles of every 30 seconds is internally converted into a pulse-width-modulated (PWM) command value signal and sent to the bus via a 1-bit switching object. Taking into account the cycle time settable using the parameter "PWM cycle time" in the parameter branch "Room temperature controller x -> RTCx - General -> Command value output", the mean value of the command signal resulting from this modulation is a measure for the centred valve position of the control valve and thus a reference for the set room temperature.

A shift of the mean value, and thus a change in the heating capacity, can be obtained by changing the duty factor of the switch-on and switch-off pulses of the command value signal.

If the command value is changed, the current PWM cycle is adapted as required so that the duty factor corresponds as directly as possible to the new command value. This adaptation is carried out in the same way as during activation of the valve outputs (see figure 8).

For a command value of 0% (permanently off) or of 100% (permanently on), a command value telegram corresponding to the command value ("0" or "1") will always be sent after a cycle time has elapsed.

For switching PI control, the controller will always use continuous command values for internal calculation. Such continuous values can additionally be sent to the bus via a separate 1-byte value object, for example, as status information for visualisation purposes (if necessary, also separately for the additional levels). The status value objects will be updated at the same time as the command value is output. The parameters "On change by (0 = inactive)" and "Cyclical (0 = inactive)" have no function here. An additional heating or cooling level as switching PI control works in the same

way as the PI control of the basic stage, with the exception that the setpoint will shift, taking account of the configured level width. All PWM control options will use the same cycle time.

#### Cycle time:

The pulse-width-modulated command values are mainly used for activating electrothermal drives (ETD). In this regard, the room temperature controller transmits the switching command value telegrams to an actuator equipped with semiconductor switching elements to which the drives are connected (e.g. heating actuator). By setting the cycle time of the PWM signal on the controller, you can adapt the feedback control to the drives used. The cycle time sets the switching frequency of the PWM signal and allows adaptation to the adjusting cycle times of the valve drives used (the adjusting time it takes the drive to bring the valve from its completely closed to its completely opened position). In addition to the adjusting cycle time, take account of the dead time (the time in which the valve drives do not show any response when being switched on or off). If different actuators with different adjusting cycle times are used, take account of the longest of the times. Always note the information given by the manufacturers of the actuators.

During cycle time configuration, a distinction can always be made between two cases...

#### Case 1: Cycle time $> 2 \times$ adjusting cycle time of the electrothermal drives used (ETA)

In this case, the switch-on or switch-off times of the PWM signal are long enough for the actuators to have sufficient time to fully open or fully close within a given time period.

#### Advantages:

The desired mean value for the command value and thus for the required room temperature will be set relatively precisely, even for several actuators triggered at the same time.

#### Disadvantages:

It should be noted, that, due to the full valve lift to be continuously 'swept', the life expectancy of the actuators can diminish. For very long cycle times ( $> 15$  minutes) with less sluggishness in the system, the heat emission into the room, for example, in the vicinity of the radiators, can possibly be non-uniform and be found disturbing.

- i This setting is recommended for sluggish heating systems (such as underfloor heating).
- i Even for a bigger number of triggered actuators, maybe of different types, this setting can be recommended to be able to obtain a better mean value of the adjusting travels of the valves.

#### Case 2: Cycle time $<$ adjusting cycle time of the electrothermal drives used (ETA)

In this case, the switch-on or switch-off times of the PWM signal are too short for the actuators to have enough time to fully open or fully close within a given period.

**Advantages:**

This setting ensures continuous water flow through the radiators, thus facilitating uniform heat emission into the room.

If only one valve drive is triggered the controller can continuously adapt the command value to compensate the mean value shift caused by the short cycle time, thus setting the desired room temperature.

**Disadvantages:**

If more than one drive is triggered at the same time the desired mean value will become the command value, which will result in a very poor adjustment of the required room temperature, or in adjustment of the latter with major deviations, respectively. The continuous flow of water through the valve, and thus the continuous heating of the drives causes changes to the dead times of the drives during the opening and closing phase. The short cycle time and the dead times means that the required command value (mean value) is only set with a possibly large deviation. For the room temperature to be regulated constantly after a set time, the controller must continually adjust the command value to compensate for the mean value shift caused by the short cycle time. Usually, the control algorithm implemented in the controller (PI control) ensures that control deviations are compensated.

- i** This setting is recommended for quick-reaction heating systems (such as surface radiators).

**Adapting the PI control**

In a building, different systems can be installed which heat up or cool down a room. One option is to uniformly heat or cool the surroundings via heat transfer media (preferably water or oil) in connection with room air convection. Such systems are used, for example, with wall mounted heaters, underfloor heating or cooling ceilings. Alternatively or additionally forced air systems may heat or cool rooms. In most cases such systems are electrical forced hot air systems, forced cool air systems or refrigerating compressors with fan. Due to the direct heating of the room air such heating and cooling systems work quite swiftly.

The control parameters need to be adjusted so that the PI control algorithm may efficiently control all common heating and cooling systems thus making the room temperature control work as fast as possible and without deviation. Certain factors can be adjusted with a PI control that can influence the control behaviour quite significantly at times. For this reason, the room temperature controller can be set to predefined control parameters for the most common heating and cooling systems. In case the selection of a corresponding heating or cooling system does not yield a satisfactory result with the default values, the adaptation can optionally be optimised using control parameters.

Predefined control parameters for the heating or cooling stage and, if applicable, also for the additional stages are adjusted via the "type of heating" or "type of cooling" parameters. These fixed values correspond to the practical values of a properly planned and executed air conditioning system and will result in an ideal behaviour of the temperature control. The heating and cooling types shown in the following tables can be set for heating and cooling operation.

Type of heating	Proportional range (preset)	Reset time (preset)	Recommended PI control type	Recommended PWM cycle time
Heat water heating	1 Kelvin	830 minutes	Continuous / PWM	15 min.
Underfloor heating	1.5 Kelvin	1000 minutes	PWM	15-20 min.
Electrical heating	1 Kelvin	830 minutes	PWM	10-15 min.
Fan coil unit	1 Kelvin	500 minutes	Continuous	---
Split unit (split climate control unit)	1 Kelvin	500 minutes	PWM	10-15 min.

#### Predefined control parameters and recommend control types for heating systems

Cooling type	Proportional range (preset)	Reset time (preset)	Recommended PI control type	Recommended PWM cycle time
Cooling ceiling	1 Kelvin	830 minutes	PWM	15-20 min.
Fan coil unit	1 Kelvin	500 minutes	Continuous	---
Split unit (split climate control unit)	1 Kelvin	500 minutes	PWM	10-15 min.
Underfloor cooling	1.5 Kelvin	1000 minutes	PWM	15-20 min.

#### Predefined control parameters and recommend control types for cooling systems

If the "Type of heating" or "Type of cooling" parameters are set to "Via control parameters", it is possible to adjust the control parameters manually. The feedback control may be considerably influenced by presetting the proportional range for heating or for cooling (P component) and the reset time for heating or for cooling (I component).

- i** Even small adjustments of the control parameters will lead to noticeable different control behaviour.
- i** The adaptation should start with the control parameter setting for the corresponding heating or cooling system according to the specified fixed values mentioned in the above tables.

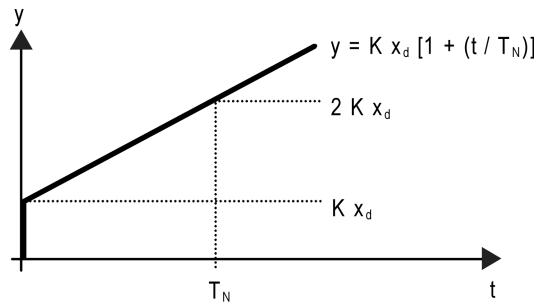

Image 28: Function of the command value of a PI control

- y: Command value
- $x_d$ : control difference ( $x_d = x_{set} - x_{act}$ )
- $P = 1/K$  : Configurable proportional band
- $K = 1/P$  : Gain factor
- $T_N$ : parameterisable reset time

PI control algorithm: Command value  $y = K x_d [1 + (t / T_N)]$

Deactivation of the reset time (setting = "0") ->  
 P control algorithm: Command value  $y = K x_d$

Parameter setting	Effect
P: Small proportional range	Large overshoot in case of setpoint changes (possibly permanently), quick adjustment to the setpoint
P: Large proportional range	no (or small) overshooting but slow adjustment
$T_N$ : Short reset time	Fast compensation of control deviations (ambient conditions), risk of permanent oscillations
$T_N$ : Long reset time	Slow compensation of control deviations

Effects of the settings for the control parameters

**2-point feedback control**

2-point feedback control represents a very simple temperature control. For this type of feedback control, two hysteresis temperature values are set. The actuators are triggered by the controller via switch-on and switch-off command value commands (1-bit type). A constant command value is not calculated for this type of control. The room temperature is also evaluated by this type of control in cycles every 30 seconds. Thus the command values change, if required, only at these times. The disadvantage of a continuously varying temperature as a result of this feedback control option is in contrast with the advantage of this very simple 2-point room temperature control. For this reason, quick-reaction heating or cooling systems should not be

triggered by a 2-point feedback control system, for this can lead to very high overshooting of the temperature, thus resulting in loss of comfort. When presetting the hysteresis limiting values, you should distinguish between the operating modes.

"Heating" or "cooling" single operating modes:

In heating mode, the controller will turn on the heating when the room temperature has fallen below a preset limit. In heating mode, the feedback control will only turn off the heating once a preset temperature limit has been exceeded. In cooling mode, the controller will turn on the cooling system when the room temperature has exceeded a preset limit. The control system will only turn off the cooling system once the temperature has fallen below a preset limit. In this connection, the command value "1" or "0" will be output, depending on the switching status, if the temperature exceeds or falls below the hysteresis limits.

The hysteresis limits of both operating modes can be configured in the ETS.

The following two images each show a 2-point feedback control for the individual operating modes "Heating" (see figure 29) or "Cooling" (see figure 30). The images take two temperature setpoints, one-stage heating or cooling and non-inverted command value output into account.

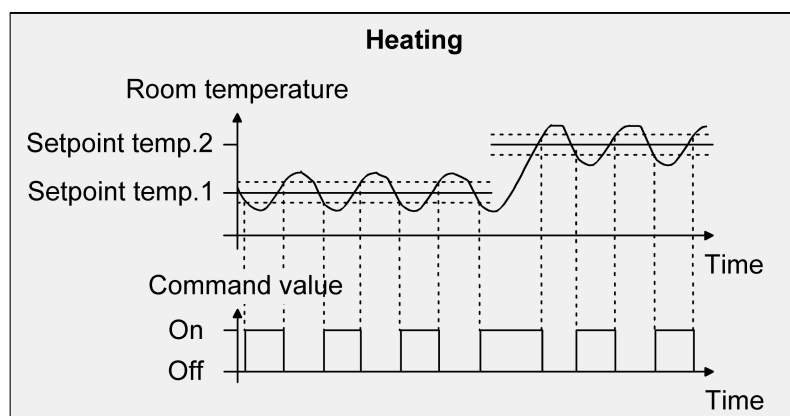

Image 29: 2-point feedback control for the single "Heating" operating mode

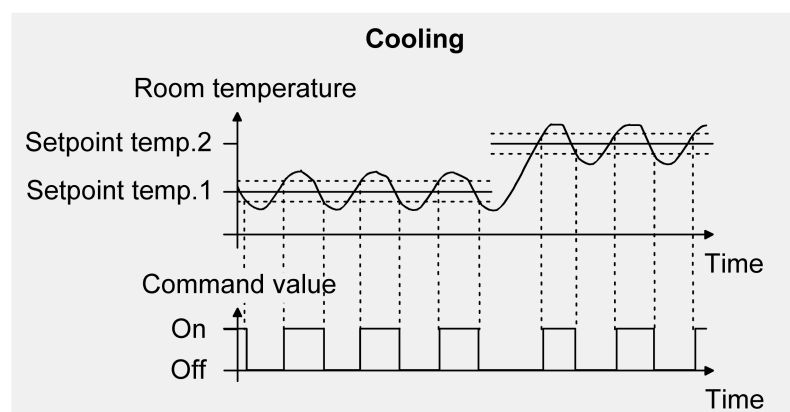

Image 30: 2-point feedback control for the single "Cooling" operating mode



An additional 2-point feedback control heating or cooling level works exactly the same as the 2-point feedback control of the basic level. The difference is that the setpoint and the hysteresis values will shift by taking into account the configured level offset.

"Heating and cooling" mixed operating mode:

In mixed operation, a distinction is made whether the change-over between heating and cooling is to be effected automatically or in a controlled way through the object...

- With automatic operating mode change-over, in the heating mode the controller will turn on the heating when the room temperature has fallen below a preset hysteresis limit. In this case, as soon as the room temperature exceeds the setpoint of the current operating mode, the feedback control will turn off the heating in the heating mode. In the same way, in cooling mode, the controller will turn on the cooling system when the room temperature has exceeded a preset hysteresis limit. As soon as the room temperature falls below the setpoint of the current operating mode, the feedback control will turn off the cooling system in the cooling mode. Thus, in mixed operation, there is no upper hysteresis limit for heating or no lower one for cooling, respectively, for these values would be in the deadband. Within the deadband, neither heating nor cooling will take place.
- With an operating mode switchover via the object, in heating mode, the controller will turn on the heating when the room temperature has fallen below a preset hysteresis limit. The feedback control will only turn off the heating in the heating mode once the preset upper hysteresis limit has been exceeded. In the same way, in cooling mode, the controller will turn on the cooling system when the room temperature has exceeded a preset hysteresis limit. The feedback control will only turn off the cooling system in the cooling mode once the temperature has fallen below the preset lower hysteresis limit. As with the individual operating modes of heating or cooling, there are two hysteresis limits per operating mode. Although there is a deadband for the calculation of the temperature setpoints for cooling, it has no influence on the calculation of the two-point command value, as the operating mode is switched over "manually" through the corresponding object. Within the hysteresis spans, it thus will be possible to request heating or cooling energy for temperature values that are located within the deadband.

The following two images show 2-point feedback control for the mixed operating mode "Heating and cooling", distinguishing between heating mode (see figure 31) and cooling mode (see figure 32). The images take two temperature setpoints, a non-inverted command value output and an automatic operating mode switchover into account. When the operating mode is switched over via the object, an upper hysteresis for heating and a lower hysteresis for cooling are active.

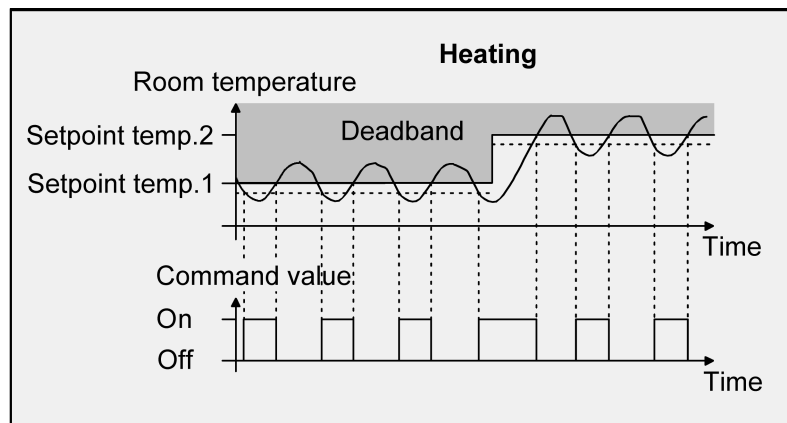

Image 31: 2-point feedback control for mixed "Heating and cooling" mode with active heating mode

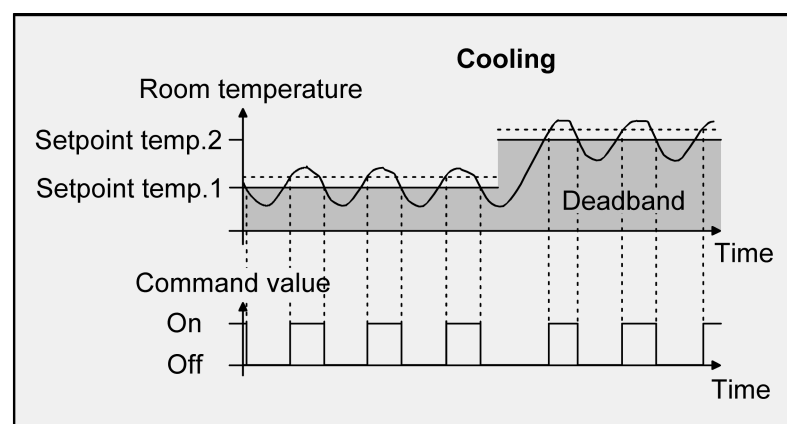

Image 32: 2-point feedback control for mixed "Heating and cooling" mode with active cooling operation

The command value "1" or "0" will be output, depending on the switching status, if the temperature exceeds or falls below the hysteresis limits or the setpoints.

An additional 2-point feedback control heating or cooling level works exactly the same as the 2-point feedback control of the basic level. The difference is that the setpoint and the hysteresis values will shift by taking into account the configured level offset.

### Adapting the 2-point feedback control

2-point feedback control represents a very simple temperature control. For this type of feedback control, two hysteresis temperature values are set. The upper and lower temperature hysteresis limits can be adjusted via parameters. It has to be considered that...

- A small hysteresis will lead to smaller temperature variations but to a higher KNX bus load.
- A large hysteresis switches less frequently but will cause uncomfortable temperature variations.

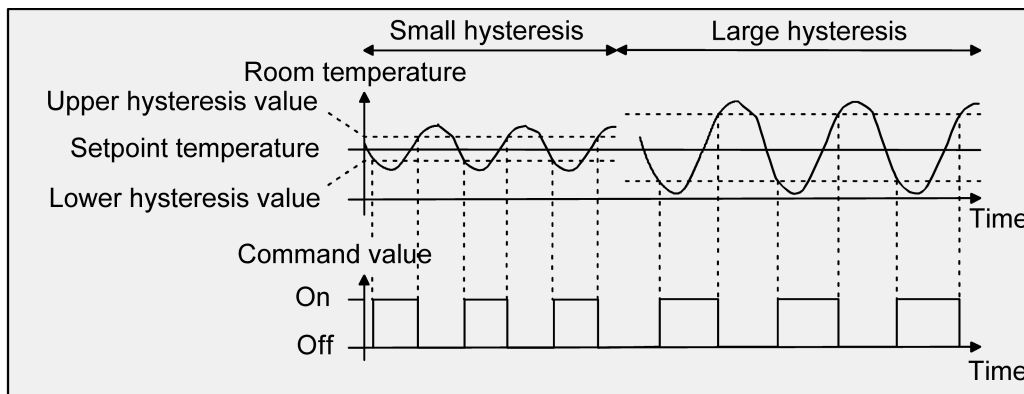

Image 33: Effects of the hysteresis on the switching behaviour of a 2-point feedback control command value

## 10.2.4 Disabling functions

### Disable additional level

The additional stage can be separately disabled when in two-stage heating or cooling mode. When set to "yes", the parameter "Additional level disabling object" in the parameter node "Room temperature controller -> RTCx - General" enables the 1-bit object "Command value outputs - Additional level - Disable". In addition, the disable function of the additional level can be switched off when set to "No". In case a "1" telegram is received via the enabled disable object, the room temperature control is completely deactivated by the additional level. The command value of the additional level is "0" while the basic level continues to operate.

- i** Disabling operation is always inactive after a device reset (bus voltage return, ETS programming operation).

### Disable controller

Certain operation conditions may require the deactivation of the room temperature control. For example, the controller can be switched-off during the dew point mode of a cooling system or during maintenance work on the heating or cooling system. When set to "yes", the parameter "Controller output disabling object" in the parameter node "Room temperature controller -> RTCx - General" enables the 1-bit object "Command value outputs - Disable". In addition, the controller disable function can be switched off when set to "No".

In case a "1" telegram is received via the enabled disable object, the room temperature control will be completely deactivated. In this case, all the command values are equal to "0"/"OFF" (wait 30 s for update interval of the command values). The controller, however, can be operated in this case via the communication objects.

## 10.2.5 Reset behaviour

### Additional information on the operating mode after a reset

In the ETS, it is possible to use the parameter "Operating mode after reset" in the parameter node "Room temperature controller -> RTCx - General" to set which operating mode is to be activated after bus voltage returns or after an ETS programming operation. The following settings are possible here...

- "Comfort" -> The Comfort mode will be activated after the initialisation phase.
- "Standby" -> The standby mode will be activated after the initialisation phase.
- "Night" -> The Night mode will be activated after the initialisation phase.
- "Frost/heat protection" -> The frost/heat protection mode will be activated after the initialisation phase.
- "Restore operating mode before reset" -> The mode set before a reset according to the operating mode objects will be restored after the initialisation phase of the device. Operating modes set by a function with a higher priority before the reset (Forced, Window status, Presence status) are not effected.

## 10.2.6 "Room temperature controller - General" parameters

Name of the controller	40-character free text
The text entered in this parameter is used to label the controller in the ETS parameter window (e.g. "Kitchen control", "Bathroom temperature"). The text is not programmed in the device.	
Operating mode	<b>Heating</b> Cooling Heating and cooling Basic and additional heating Basic and additional cooling Basic and additional heating and cooling
<p>The room temperature controller distinguishes between two different operating modes. The operating modes specify whether you want the controller to use its command value to trigger heating systems ("heating" single operating mode) or cooling systems ("cooling" single operating mode). You can also activate mixed operation, with the controller being capable of changing over between "Heating" and "Cooling" either automatically or, alternatively, controlled by a communication object.</p> <p>In addition, you can establish two-level control operation to control an additional heating or cooling unit. For two-level feedback control, separate command values will be calculated as a function of the temperature deviation between the setpoint and the actual value and transmitted to the bus for the basic and additional levels. This parameter specifies the operating mode and, if necessary, enables the additional level(s).</p>	

Command values for heating and cooling	to separate objects (4-pipe / 2 circuits) to shared object (2-pipe / 1 circuit)
<p>If the parameter is set to "Yes", the command value will be transmitted to a shared object during heating or cooling. This function is used, if the same heating system is used to cool the room in the summer and used to heat the room in the winter.</p> <p>This parameter is only visible with "Heating and cooling" mixed operating mode.</p>	
Additional separate command value objects	Checkbox (yes / no)
<p>If the parameter is set to "yes", two separate objects "Command value heating" and "Command value cooling" are displayed in addition to the shared object "Command value heating/cooling". These objects are for both visualisation purposes and also rooms with, for example, combined wall heating/cooling and separate underfloor heating.</p> <p>This parameter is only visible in the mixed "Heating and cooling" operating mode with output of the command values to a shared object.</p>	
Type of heating control (if applicable, for basic and additional level)	continuous PI control switching PI control (PWM) switching 2-point feedback control
<p>Selecting a feedback control algorithm (PI or 2-point) with data format (1-byte or 1-bit) for the heating system.</p>	
Type of heating (if applicable, for basic and additional level)	Hot water heater (1.0 K / 830 min) Underfloor heating (1.5 K / 1000 min) Electric heating (1.0 K / 830 min) Fan coil unit (1.0 K / 500 min) Split unit (1.0 K / 500 min) via control parameter
<p>Adapting the PI algorithm to different heating systems using predefined values for the proportional range and reset time control parameters.</p> <p>With the "Using control parameters" setting, it is possible to set the control parameters in a manner deviating from the predefined values within specific limits.</p> <p>This parameter is only visible if "Type of heating control = Continuous PI control".</p>	
Proportional range	1...5...12.7 K
<p>Separate setting of the "Proportional range" control parameter.</p> <p>This parameter is only visible if "Type of heating = via control parameter" and the heating control type "PI control".</p>	
Reset time (0 = inactive)	0...830...2550 min
<p>Separate setting of the "Reset time" control parameter.</p> <p>This parameter is only visible if "Type of heating = via control parameter" and the heating control type "PI control".</p>	

Lower hysteresis limit	-12.8...-0.5 K
Definition of bottom hysteresis (switch-on temperatures) of the heating. This parameter is only visible if "Type of heating control = Switching 2-point feedback control (ON/OFF)".	
Upper hysteresis limit	0.5...12.7 K
Definition of top hysteresis (switch-off temperatures) of the heating. This parameter is only visible if "Type of heating control = Switching 2-point feedback control".	
Type of control (if applicable, for basic and additional level)	<b>continuous PI control</b> switching PI control (PWM) switching 2-point feedback control
Selecting a feedback control algorithm (PI or 2-point) with data format (1 byte or 1 bit) for the cooling system	
Type of cooling (if applicable, for basic and additional level)	<b>Cooling ceiling (1.0 K / 830 min)</b> Fan coil unit (1.0 K / 500 min) Split unit (1.0 K / 500 min) Floor cooling (1.5 K / 1000 min) via control parameter
Adapting the PI algorithm to different cooling systems using predefined values for the proportional range and reset time control parameters. With the "Using control parameters" setting, it is possible to set the control parameters in a manner deviating from the predefined values within specific limits. This parameter is only visible if "Type of cooling control = PI control".	
Proportional range	1...5...12.7 K
Separate setting of the "Proportional range" control parameter. This parameter is only visible if "Type of cooling = via control parameter" and the cooling control type "PI control".	
Reset time (0 = inactive)	0...830...2550 min
Separate setting of the "Reset time" control parameter. This parameter is only visible if "Type of cooling = via control parameter" and the cooling control type "PI control".	
Lower hysteresis limit	-12.8...-0.5 K
Definition of bottom hysteresis (switch-off temperatures) of the cooling. This parameter is only visible if "Type of cooling control = Switching 2-point control".	
Upper hysteresis limit	0.5...12.7 K
Definition of top hysteresis (switch-on temperatures) of the cooling. This parameter is only visible if "Type of cooling control = Switching 2-point control".	

Heating/cooling switchover	automatic via RTC via object
<p>In a configured mixed mode it is possible to switch over between heating and cooling.</p> <p>With "automatic via RTC": Depending on the operating mode and the room temperature, the switchover takes place automatically.</p> <p>With "via object": The switchover takes place only via the object "Operating mode".</p>	
Additional stage inhibit object	Checkbox (yes / no)
<p>The additional stages can be separately disabled via the bus. The parameter enables the disable object as necessary.</p> <p>This parameter is only visible in two-level heating and cooling operation.</p>	
Controller output disabling object	Checkbox (yes / no)
<p>This parameter enables the "Disable command value outputs" object. If the controller is disabled, there is no feedback control until enabled (command values = 0).</p>	
Operation mode after reset	Restore operating mode before reset Comfort <b>Standby</b> Night Frost/heat protection
<p>This parameter specifies which operating mode is set immediately after a device reset.</p> <p>With "Restore operation mode before reset": The mode set before a reset according to the operating mode object will be restored after the initializing phase of the device. Operating modes set by a function with a higher priority before the reset (Forced, Window status, Presence status) are not effected.</p>	

## 10.3 Operating mode and setpoints

### Introduction - Operating modes

The room temperature controller has various operating modes. The selection of these modes will, for example, facilitate the activation of different temperature setpoints, depending on the presence of a person, on the state of the heating or cooling system, on the time of the day, or on the day of the week. The following operating modes can be distinguished:

- Comfort
 

Comfort mode is usually activated if persons are in a room, and the room temperature should, for this reason, be adjusted to an adequately convenient value. The switchover to this operating mode can take place either by specifying an operating mode via the operating mode switchover or with presence control, for example, using a PIR presence detector on the wall or a ceiling mounted presence detector.
- Standby



If a room is not used during the day because persons are absent, you can activate the Standby mode. Thereby, you can adjust the room temperature on a standby value, thus to save heating or cooling energy, respectively.

- Night

During the night hours or during the absence of persons for a longer time, it mostly makes sense to adjust the room temperature to lower values for heating systems (e.g. in bedrooms). In this case, cooling system can be set to higher temperature values, if air conditioning is not required (e.g. in offices). For this purpose, you can activate the Night mode.

- Frost/heat protection

Frost protection will be required if, for example, the room temperature must not fall below critical values while the window is open. Heat protection can be required where the temperature rises too much in an environment which is always warm, mainly due to external influences. In such cases, you can activate the Frost/heat protection operating mode and prescribe some temperature setpoint of its own for either option, depending on whether "Heating" or "Cooling" has been selected, to prevent freezing or overheating of the room.

- Comfort extension (temporary Comfort mode)

You can activate the comfort extension from the Night or Frost/heat protection mode (not triggered by the "Window status" object) and use it to adjust the room temperature to a comfort value for some time if, for example, there are people in the room during the night hours. This mode can exclusively be activated via the presence object. The comfort extension option will be automatically deactivated after a definable time has elapsed, or by receiving a presence object value = "0". You cannot retrigger this extension.

**i** You can assign your own setpoint temperature to the "Heating" or "Cooling" operating modes for each operating mode.

## Operating mode switchover

The operating mode is switched by the "Operating mode - Preset" object.

During the running time, the operating mode can be changed over through this value object immediately after the receipt of only one telegram. In this connection, the value received will set the operating mode. In addition, a second 1-byte object is available which, by forced control and through a higher level, can set an operating mode, irrespective of any other switchover options.

Taking the priority into account, a specific switchover hierarchy will result from the operating mode switchover by the objects, a distinction being made between presence detection by the presence button (see figure 34) or the presence detector (see figure 35). In addition, the status of the windows in the room can be evaluated using the "Frost/heat protection - Window contact - Status" object, meaning that, when a window is open, the controller can switch to frost/heat protection mode, irrespective of the set operating mode, in order to save energy .

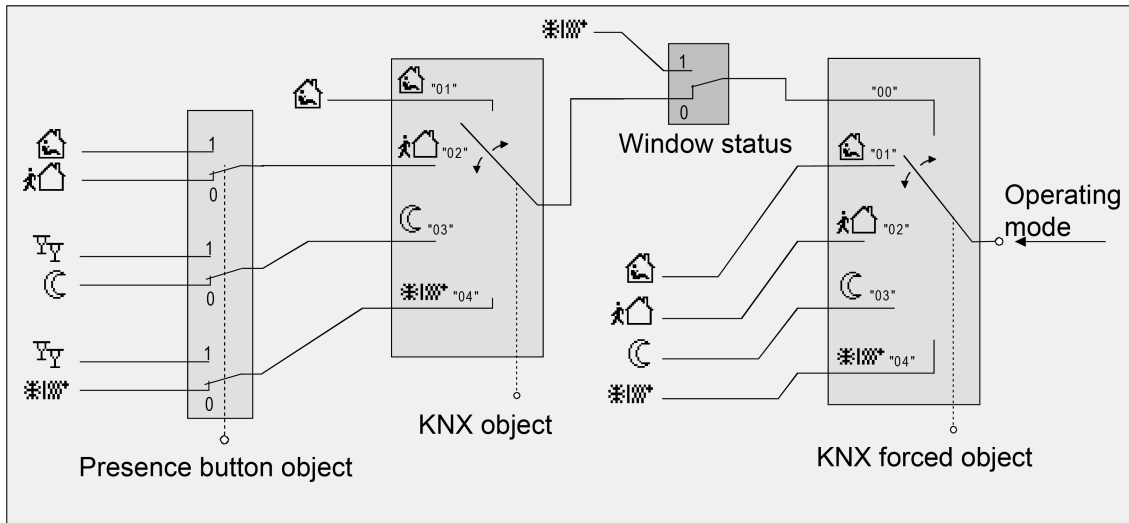

Image 34: Operating mode switchover through KNX object with presence button

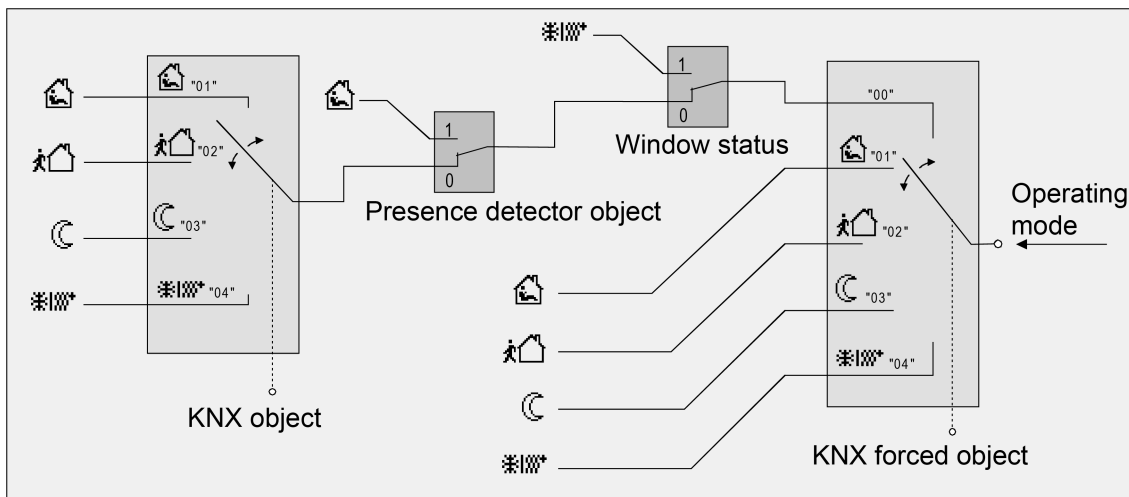

Image 35: Operating mode switchover through KNX object with presence detector

Object value Operating mode	Object value Forced ob- ject Oper.m.	object Window status	Pres- ence button	Pres- ence detector	Resulting operating mode
00	00	0	X	0	No modification
01	00	0	0	-	Comfort
02	00	0	0	-	Standby
03	00	0	0	-	Night
04	00	0	0	-	Frost/heat protec- tion
01	00	0	1	-	Comfort
02	00	0	1	-	Comfort
03	00	0	1	-	Comfort ex- tension
04	00	0	1	-	Comfort ex- tension

Object value Operating mode	Object value Forced ob- ject Oper.m.	object Window status	Pres- ence button	Pres- ence detector	Resulting operating mode
01	00	0	-	0	Comfort
02	00	0	-	0	Standby
03	00	0	-	0	Night
04	00	0	-	0	Frost/heat protec- tion
X	00	0	-	1	Comfort
X	00	1	-	X	Frost/heat protec- tion
X	00	1	X	-	Frost/heat protec- tion
X	01	X	X	X	Comfort
X	02	X	X	X	Standby
X	03	X	X	X	Night
X	04	X	X	X	Frost/heat protec- tion

Status of the communication objects and the resulting operating mode

X: Status irrelevant

-: Not possible

- i** After voltage return or after an ETS programming operation, the value corresponding to the set operating mode is actively transmitted to the bus if the "Transmit" flag is set.
- i** In parameterisation of a presence button: the presence object will be active ("1") for the period of an active comfort extension. The presence object will be automatically deleted ("0") if the comfort extension is stopped after the extension time has elapsed, or if the operating mode has been changed by an operation through the switchover objects or a forced operating mode is deactivated by the KNX forced object (forced object -> "00"). The controller therefore automatically resets the status of the presence button when an object value is received via the operating mode objects or the forced object is reset.

### Additional information on the presence function / comfort extension

With presence detection, the room temperature controller can quickly switch over to a comfort extension upon push-button actuation using a presence button or, using a presence detector, switch to Comfort mode when movement by a person in the room is detected.

The parameter "Presence detection" in the parameter node "RTCx - General -> Enabled functions" enables the parameter page "Presence detection". The remaining parameters can be set there.

In this regard, the parameter "Presence detection" determines whether presence detection is movement-controlled by a presence detector or done manually using a presence button:

- Presence detection by the presence button

The 1-bit communication object "Presence detection - Presence button" is enabled. An "ON" telegram to this object makes it possible to switch to the comfort extension if Night or Frost/heat protection mode (not activated by the "Window status" object!) is active. The extension will be automatically deactivated as soon as the configured "Length of comfort extension" time has elapsed. A comfort extension can be deactivated in advance if an "OFF" telegram is received via the object of the presence button. You cannot re-trigger such extension time.

If you have set the length of comfort extension to "0" in the ETS, you cannot activate a comfort extension from the Night or Frost/heat protection mode. In this case, the operating mode will not be changed, although the presence function has been activated.

If the standby mode is active, actuation on a presence object value = "ON" allows a switchover to the Comfort mode. This will also be the case if you have configured the length of comfort extension to "0". Comfort mode will remain active as long as the presence function remains active, or until another operating mode is specified.

The presence function will always be deleted whenever a switchover to a different operating mode takes place, or after a forced operating mode has been deactivated (associated with KNX forced switchover). In the event of a device reset (voltage failure, ETS programming operation), an active presence function is always deleted.

**i** If, during an active comfort extension and with a frost/heat protection switchover being configured "via window status", a window is opened, then the controller will activate frost/heat protection immediately. The comfort extension remains active in the background and the configured time continues to elapse. If the time elapses and the window remains open, the presence is reset and an appropriate telegram is sent to the bus. However, if the window is closed again before the time has elapsed, then the comfort extension is executed again with the remaining run time.

- Presence detection by the presence detector

Two 1-bit communication objects "Presence detection - Presence object" are enabled. With this objects it is possible to integrate presence detectors into room temperature control. If a movement is detected ("ON" telegram), the controller will switch to Comfort mode. In this connection, it is irrelevant what has been set by the switchover objects. Only a window contact or the KNX forced object are of higher priority.

Both objects form an "Or" link of two presence detectors. In larger rooms, the use of two presence detectors can be useful. As long as one of the two detectors detects a presence, the controller remains in Comfort mode.

After the delay time has elapsed in the presence detector after a detected movement ("OFF" telegram), the controller will return to the mode which was active before presence detection, or it will compensate the telegrams of the operating mode objects received during presence detection, respectively.

In the event of a device reset (voltage failure, ETS programming operation), an active presence function is always deleted. In this case, the presence detector must transmit a new "1"-telegram to the controller to activate the presence function.

### **Additional information on the window status and the automatic frost protection**

The room temperature controller offers various options to change over into the Frost/heat protection mode. In addition to switching over by means of the corresponding operating mode switchover object, frost/heat protection can be activated by a window contact, or alternatively, the frost protection can be activated by an automatic temperature function. The window contact or the automatic function has higher priority. The "Frost/heat protection" parameter determines how the switchover to forced frost/heat protection takes place:

- Frost/heat protection switchover "via window contact (frost and heat protection)"

The 1-bit object "Window contact" is enabled. A telegram having the value of = "ON" (open window) and sent to this object will activate the frost/heat protection mode. If this is the case, the operating mode cannot be deactivated by the switchover objects (except for the KNX forced object) or the presence function. Only a telegram with the value = "OFF" (closed window) will reset the window status and deactivate the frost/heat protection mode. After this, the operating mode set before the opening of the window or that mode carried by the bus while the window was open will be activated.

You can optionally configure a delay for the evaluation of the window status. Such delay can make sense if short ventilation of the room by opening the window is not supposed to change the operating mode. The delay time is set by the "Delay time" parameter and can be between 1 and 255 minutes. The window status will only be changed and thus the frost/heat protection mode activated after this parameterized time has elapsed. A setting of "0" will effect the immediate activation of the frost/heat protection mode when the window is open. The window status will be in effect in the heating and in the cooling mode. After a voltage failure or ETS programming operation, the window status is always inactive.

- Frost protection mode switchover "via temperature drop (frost protection only)"

For this setting, automatic switchover to the frost protection mode can be made at times, depending on the room temperature determined.

If there are no window contacts, this setting can prevent unnecessary heating up of a room when windows or external doors are open.

With this function, a quick temperature drop can be detected by measuring the actual temperature every 4 minutes as is the case when a window is open in the winter months, for example. You can use the "Temperature drop detection

from" parameter to set the maximum temperature drop in K / 4 min for switching over to the frost protection mode. If the controller detects that the room temperature has changed by at least the configured temperature jump within four minutes, frost protection is activated. After the time specified by the "Frost protection period" parameter has elapsed, the controller again automatically switches to the operating mode which was set before frost protection or which was tracked during automatic operation. It is not possible to retrigger an elapsing frost protection period.

- i** An activated automatic frost protection is cancelled by a setpoint shift, a setpoint change or an increase in the room temperature by 1 Kelvin.
- i** The KNX override object has a higher priority than the automatic frost protection mode and can interrupt the latter.
- i** The automatic frost protection mode only acts on heating for temperatures below the set value temperature of the operating mode selected. Thus, no automatic switchover to frost protection can take place at room temperatures in the deadband or in the active cooling mode if the "Heating and cooling" operating mode is on. Automatic heat protection activation is not intended with this parameterization.
- i** Frequent draughts in a room can cause unintentional activation/deactivation of frost protection when the automatic frost protection mode is active and if the set temperature decrease is too low. Therefore switching into the frost/heat protection mode by window contacts should generally be preferred to the automatic option.

### Setpoint temperature presetting

Setpoint temperatures can be specified for each operating mode in the ETS as part of configuration. It is possible to configure the setpoints for the "Comfort", "Standby" and "Night" modes directly (absolute setpoint presetting) or relatively (derivation from basic setpoint). The setpoint temperatures can later be adapted during regular operation by KNX communication objects if desired.

- i** The "Frost/heat protection" operating mode allows the separate configuration of two temperature setpoints for heating (frost protection) and cooling (heat protection) solely in the ETS. These temperature values cannot be changed later during controller operation.

The "Setpoint specification" parameter on the parameter page "Room temperature controller -> RTCx - General -> Setpoints" defines the way the setpoint temperature is specified...

- Setting "relative"  
When presetting the set-temperatures for Comfort, Standby and Night mode, attention has to be paid to the fact that all setpoints depend on each other as all values are derived from the basic temperature (basic setpoint). The parameter "Setpoint temperature - Basic value" on the parameter page "Room temperature controller -> RTCx - General -> Setpoints" determines the basic setpoint, which is loaded as a preset value when the device is programmed via



the ETS. Taking into account the "Standby" and "Night" parameters under the header "Temperature shift via operating mode", the temperature setpoints for the standby and night mode are derived from this value depending on the heating or cooling operating mode. The deadband will be additionally considered for the "Heating and cooling" operating mode.

The 2-byte object "Basic setpoint" provides the option of changing the basic temperature, and thus all the dependent setpoint temperatures during device operation. A change via the object must always be enabled in the ETS by configuring the parameter "Approve activations via bus" to "yes". If the basic setpoint adjustment via the bus is disabled, the "Basic setpoint" object will be hidden. The controller rounds the temperature values received via the object to the specified "Step width of the setpoint shift" (0,1 K or 0,5 K).

– Setting "absolute"

The setpoint temperatures for Comfort, Standby and Night mode are independent of each other. Depending on the operating mode and heating/cooling mode, various temperature values can be specified in the ETS within the range +7.0 °C to +40.0 °C. The ETS does not validate the temperature values. It is thus possible, for example, to select smaller setpoint temperatures for cooling mode than for heating mode, or to specify lower temperatures for Comfort mode than for Standby mode.

After commissioning using the ETS the setpoint temperatures can be changed via the bus by means of temperature telegrams. This can be done using the communication object "Setpoint temperature - Active operating mode". When the controller receives a telegram via this object, it immediately sets the received temperature as the new setpoint of the active operating mode, and operates from then on with this setpoint. In this manner it is possible to adapt the setpoint temperatures of all operating modes separately for heating and cooling mode. The frost or heat protection temperature programmed using the ETS cannot be changed in this manner.

**i** With absolute setpoint presetting there is no basic setpoint and, in the mixed operating mode "Heating and cooling" (if necessary also with additional level), also no deadband. Consequently, the room temperature controller cannot control the switchover of the operating mode automatically, which is why, in this configuration, the setting for the parameter "Heating/cooling switchover" is fixed in the ETS to "via object".

Furthermore, setpoint shifting does not exist for absolute setpoint presetting.

**i** In two-level control mode, all set-temperatures of the additional level are derived from the setpoint temperatures of the basic level. The setpoint temperature of the additional level are determined by subtracting the "Difference between basic and additional levels", which is permanently configured in the ETS, from the setpoints of the basic level in heating mode or by adding the setpoints in cooling mode. If the temperature setpoints of the basic level are changed, the setpoint temperatures of the additional level will be automatically changed as well. Both levels will heat or cool with the same command value at the same time when the level distance is "0".



The temperature setpoints programmed in the room temperature controller by the ETS during commissioning can be changed via communication objects. In the ETS, the parameter "Overwrite setpoints in the device during ETS programming" on the parameter page "Room temperature controller -> RTCx - General -> Setpoints" can be used to determine whether the setpoints that are present in the device and may have been subsequently changed are overwritten during an ETS programming operation and thus replaced again by the values configured in the ETS. If this parameter is "Yes", then the setpoint temperatures are deleted in the device during a programming operation and replaced by the values of the ETS. If this parameter is configured to "No", then setpoints present in the device remain unchanged. The setpoint temperatures entered in the ETS then have no significance.

**i** During initial commissioning of the device the parameter "Overwrite setpoints in device during ETS programming" must be set to "yes" in order to perform valid initialisation of the memory slots in the device. The setting "Yes" is also necessary if essential controller properties (operating mode, setpoint specification, etc.) are changed in the ETS through new parameter configurations.

**Setpoint temperatures for relative setpoint presetting**

Depending on the operating mode, different cases should be distinguished when specifying the relative setpoint temperature, which then have an impact on the temperature derivation from the basic setpoint.

Setpoints for operating mode "Heating"

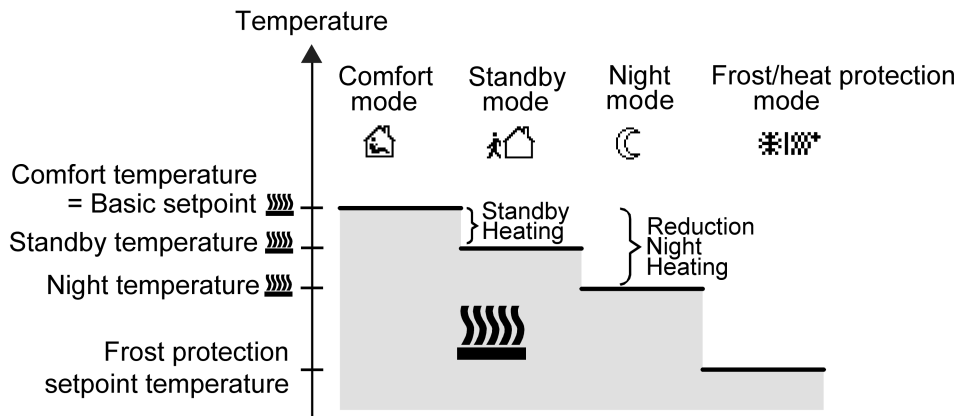

Image 36: Setpoint temperatures in the operating mode "Heating"

The setpoint temperatures for Comfort, Standby and Night mode exist in this operating mode and the frost protection temperature can be preset (see figure 36). The following applies...

$$T_{\text{Standby setpoint heating}} \leq T_{\text{Comfort setpoint heating}}$$

or

$$T_{\text{Night setpoint heating}} \leq T_{\text{Comfort setpoint heating}}$$

The Standby and Night setpoint temperatures are derived from the reduction temperatures configured in the ETS from the comfort setpoint temperature (basic setpoint). The frost protection is supposed to prevent the heating system from freezing. For this

reason, the frost protection temperature (default: +7 °C) should be set to a lower value than the night temperature. In principle, however, it is possible to select frost protection temperature values between +7.0 °C and +40.0 °C. The possible range of values for a setpoint temperature is bounded by the frost protection temperature in the lower range.

The level offset configured in ETS will be additionally considered in a two-level heating mode (see figure 37).

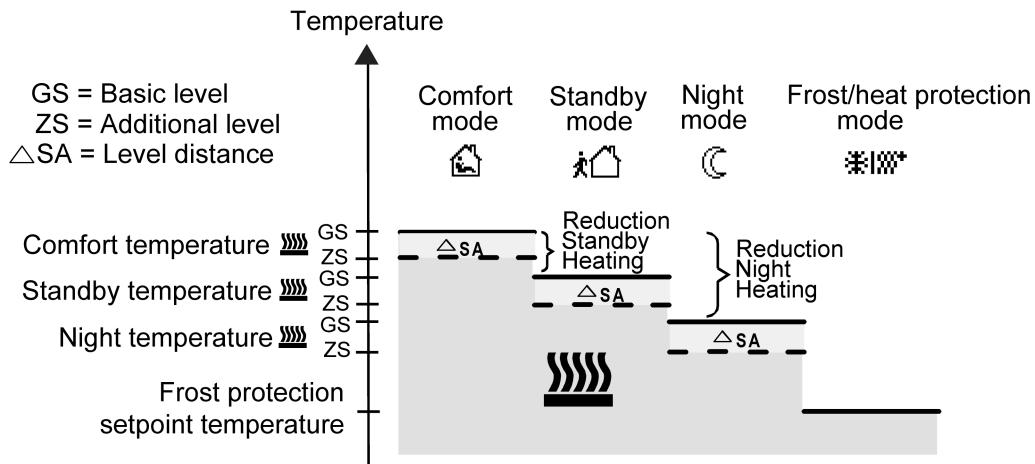

Image 37: Setpoint temperatures in the operating mode "Basic and additional heating"

$$T_{\text{Comfort setpoint additional level heating}} \leq T_{\text{Comfort setpoint basic level heating}}$$

$$T_{\text{Standby setpoint additional level heating}} \leq T_{\text{Standby setpoint basic level heating}}$$

$$T_{\text{Standby setpoint heating}} \leq T_{\text{Comfort setpoint heating}}$$

or

$$T_{\text{Comfort setpoint additional level heating}} \leq T_{\text{Comfort setpoint basic level heating}}$$

$$T_{\text{Night setpoint additional level heating}} \leq T_{\text{Night setpoint basic level heating}}$$

$$T_{\text{Night setpoint heating}} \leq T_{\text{Comfort setpoint heating}}$$

Setpoints for the "cooling" operating mode

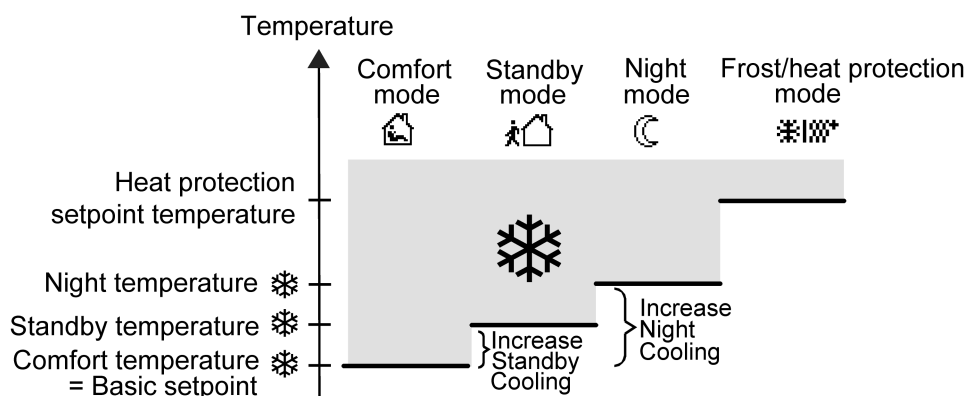

Image 38: Setpoint temperatures in the operating mode "Cooling"

The setpoint temperatures for Comfort, Standby and Night mode exist in this operating mode and the heat protection temperature can be preset (see figure 38).

The following applies...

$$T_{\text{Comfort setpoint cooling}} \leq T_{\text{Standby setpoint cooling}}$$

or

$$T_{\text{Comfort setpoint cooling}} \leq T_{\text{Night setpoint cooling}}$$

The standby and night setpoint temperatures are derived after the configured increase temperatures from the comfort setpoint temperature (basic setpoint). The heat protection is intended to ensure that the temperature does not exceed the maximum permissible room temperature in order to protect system components. For this reason, the heat protection temperature (default: +35 °C) should be set to a higher value than the night temperature. In principle, however, it is possible to select heat protection temperature values between +7.0 °C and +45.0 °C. The possible range of values for a setpoint temperature is bounded by the heat protection temperature in the upper range.

The level offset configured in ETS will be additionally considered in a two-level cooling mode (see figure 39).

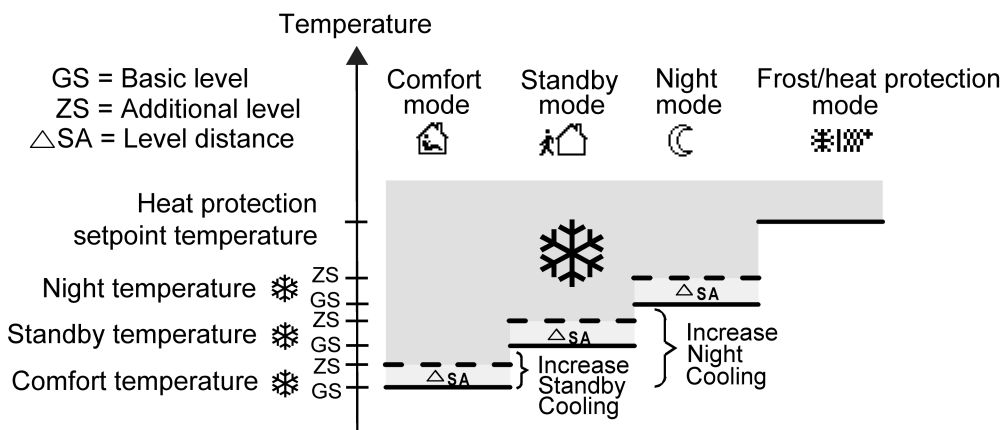

Image 39: Setpoint temperatures in the operating mode "Basic and additional cooling"

$$T_{\text{Comfort setpoint basic level cooling}} \leq T_{\text{Comfort setpoint additional level cooling}}$$

$$T_{\text{Standby setpoint basic level cooling}} \leq T_{\text{Standby setpoint additional level cooling}}$$

$$T_{\text{Comfort setpoint cooling}} \leq T_{\text{Standby setpoint cooling}}$$

or

$$T_{\text{Comfort setpoint basic level cooling}} \leq T_{\text{Comfort setpoint additional level cooling}}$$

$$T_{\text{Night setpoint basic level cooling}} \leq T_{\text{Night setpoint additional level cooling}}$$

$$T_{\text{Comfort setpoint cooling}} \leq T_{\text{Night setpoint cooling}}$$

Setpoints for the "heating and cooling" operating mode

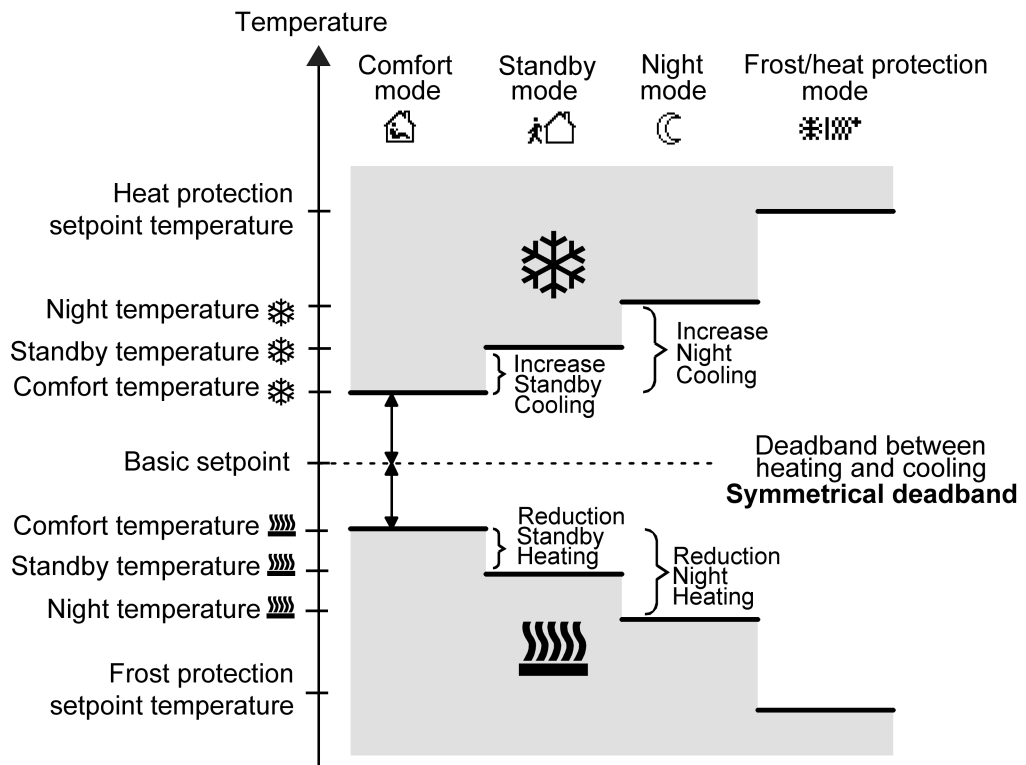

Image 40: Setpoint temperatures in the operating mode "Heating and cooling" with symmetrical deadband

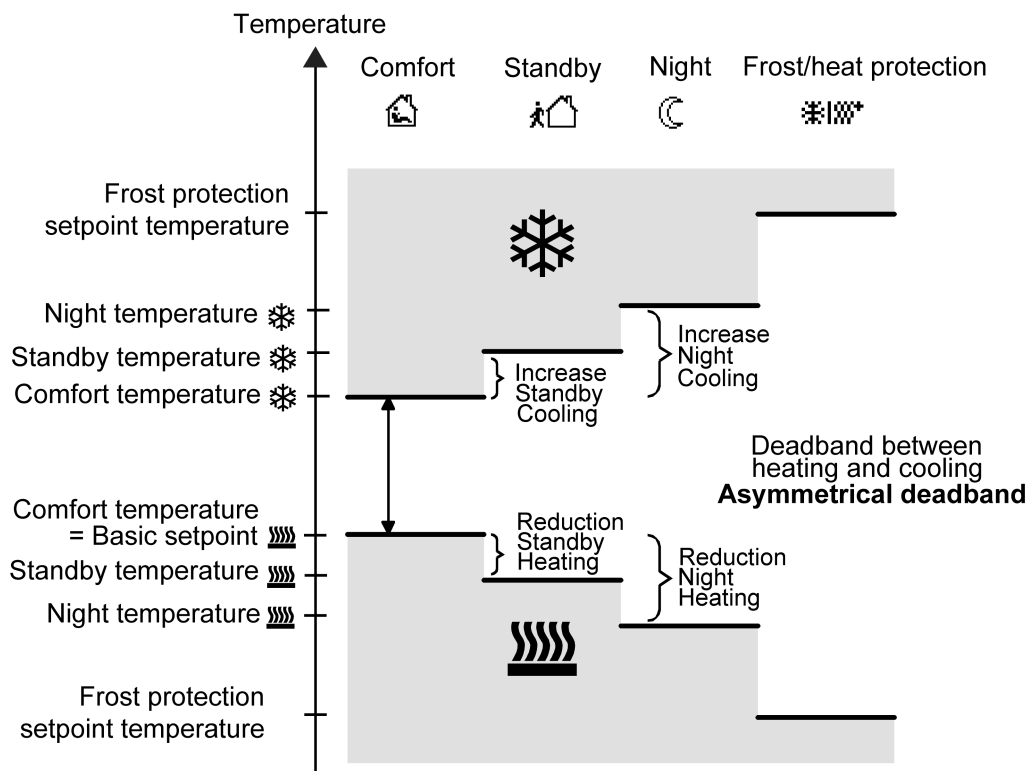

Image 41: Setpoint temperatures in the operating mode "Heating and cooling" with asymmetrical deadband

For this heating/cooling operating mode, the setpoint temperatures of both heating/cooling modes exist for the Comfort, Standby and Night operating modes as well as the deadband. A distinction is made in the deadband position with combined heating

and cooling. A symmetrical (see figure 40) or an asymmetrical (see figure 41) dead-band position can be configured. In addition, the frost protection and the heat protection temperatures can be preset.

The following applies...

$$T_{\text{Standby setpoint heating}} \leq T_{\text{Comfort setpoint heating}} \leq T_{\text{Comfort setpoint cooling}} \leq T_{\text{Standby setpoint cooling}}$$

or

$$T_{\text{Night setpoint heating}} \leq T_{\text{Comfort setpoint heating}} \leq T_{\text{Comfort setpoint cooling}} \leq T_{\text{Night setpoint cooling}}$$

The standby and night setpoint temperatures are derived from the comfort setpoint temperatures for heating or cooling. The temperature increase (for cooling) and the temperature decrease (for heating) of both operating modes can be preset in ETS. The comfort temperatures themselves are derived from the deadband and the basic setpoint. The frost protection is supposed to prevent the heating system from freezing. For this reason, the frost protection temperature (default: +7 °C) should be set to a lower value than the night temperature for heating. In principle, however, it is possible to select frost protection temperature values between +7.0 °C and +40.0 °C. The heat protection is intended to prevent the temperature from exceeding the maximum permissible room temperature in order to protect system components. For this reason, the heat protection temperature (default: +35 °C) should be set to a higher value than the night temperature for cooling. In principle, however, it is possible to select heat protection temperature values between +7.0 °C and +45.0 °C. The possible range of values for a setpoint temperature ("heating and cooling") lies between +7.0 °C and +45.0 °C and is bounded by the frost protection temperature in the lower range and by the heat protection temperature in the upper range.

The level offset configured in ETS will be additionally considered in a two-level heating or cooling mode.

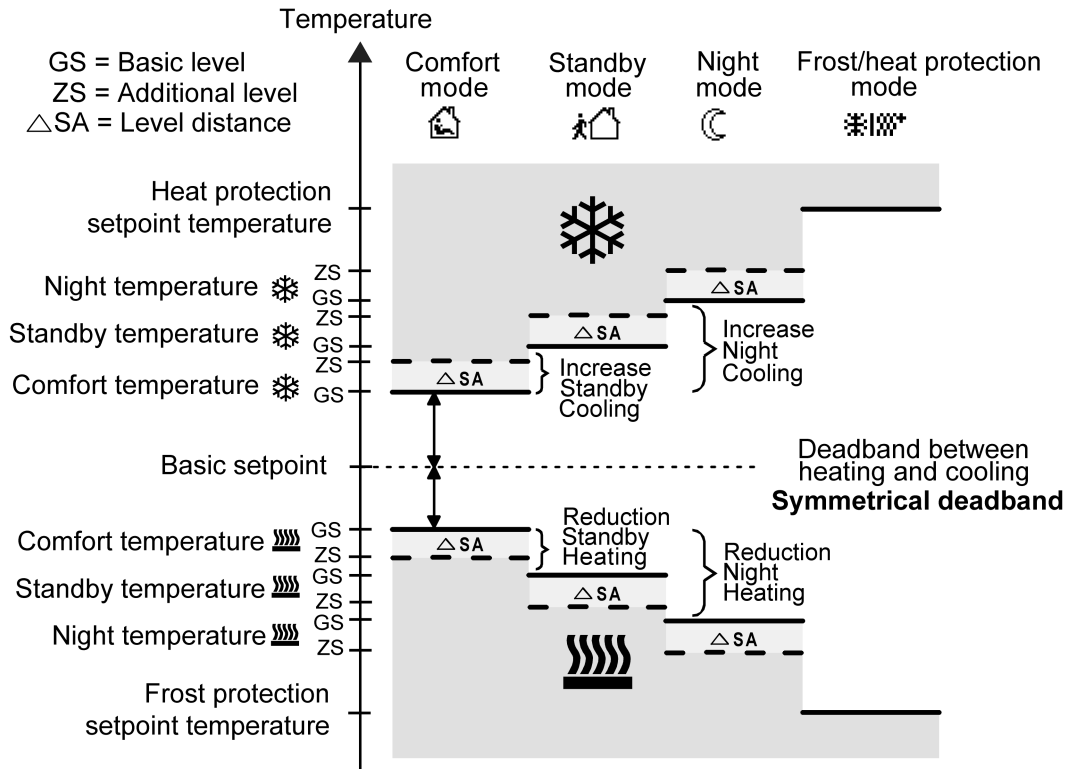

Image 42: Setpoint temperatures in the operating mode "Basic and additional heating and cooling" with symmetrical deadband

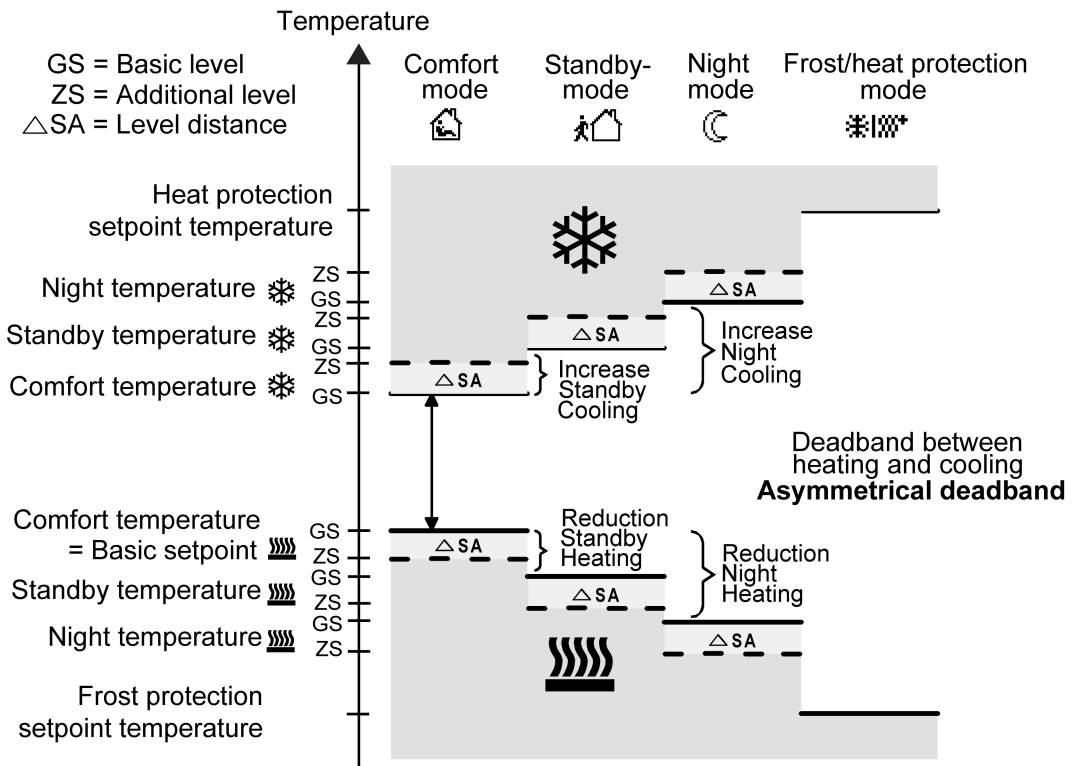

Image 43: Setpoint temperatures in the operating mode "Basic and additional heating and cooling" with asymmetrical deadband

$$T_{\text{Comfort setpoint add. level Heating}} \leq T_{\text{Comfort setpoint basic level Heating}} \leq T_{\text{Comfort setpoint basic level Cooling}} \leq T_{\text{Comfort setpoint add. level Cooling}}$$

$$T_{\text{Standby setpoint add. level Heating}} \leq T_{\text{Standby setpoint basic level Heating}} \leq T_{\text{Standby setpoint basic level Cooling}} \leq T_{\text{Standby setpoint add. level Cooling}}$$

$$T_{\text{Standby setpoint heating}} \leq T_{\text{Comfort setpoint heating}} \leq T_{\text{Comfort setpoint cooling}} \leq T_{\text{Standby setpoint cooling}}$$

or

$$T_{\text{Comfort setpoint add. level Heating}} \leq T_{\text{Comfort setpoint basic level Heating}} \leq T_{\text{Comfort setpoint basic level Cooling}} \leq T_{\text{Comfort setpoint add. level Cooling}}$$

$$T_{\text{Night setpoint add. level Heating}} \leq T_{\text{Night setpoint basic level Heating}} \leq T_{\text{Night setpoint basic level Cooling}} \leq T_{\text{Night setpoint add. level Cooling}}$$

$$T_{\text{Night setpoint heating}} \leq T_{\text{Comfort setpoint heating}} \leq T_{\text{Comfort setpoint cooling}} \leq T_{\text{Night setpoint cooling}}$$

**i** In the case of switching 2-point feedback control, the hysteresis values must additionally be taken into account.

Deadband and deadband positions in the combined heating and cooling operating mode

With relative setpoint presetting, the comfort setpoint temperatures for heating and cooling are derived from the basic setpoint in consideration of the set deadband. The deadband (temperature zone for which there is neither heating nor cooling) is the difference between the comfort setpoint temperatures. This deadband does not exist for absolute setpoint presetting.

The parameters "Deadband between heating and cooling", "Allocation of deadband" and "Basic setpoint temperature" are specified in the ETS configuration. One distinguishes between the following settings...

- Allocation of deadband = "symmetrical"  
The deadband preset in the ETS is divided into two parts at the basic setpoint. Based on the resulting half deadband, the comfort setpoint temperatures are derived directly from the basic setpoint. The following applies...

$$T_{\text{Basic setpoint}} - \frac{1}{2}T_{\text{Deadband}} = T_{\text{Comfort setpoint heating}}$$

and

$$T_{\text{Basic setpoint}} + \frac{1}{2}T_{\text{Deadband}} = T_{\text{Comfort setpoint cooling}}$$

$$\rightarrow T_{\text{Comfort setpoint cooling}} - T_{\text{Comfort setpoint heating}} = T_{\text{Deadband}}$$

$$\rightarrow T_{\text{Comfort setpoint cooling}} \geq T_{\text{Comfort setpoint heating}}$$

- Allocation of deadband = "asymmetrical"  
With this setting the comfort setpoint temperature for heating equals the basic setpoint. The deadband preset in the ETS is effective only from the basic setpoint in the direction of comfort temperature for cooling. Thus the comfort setpoint temperature for cooling is derived directly from the comfort setpoint for heating.

The following applies...

$$T_{\text{Basic setpoint}} = T_{\text{Comfort setpoint heating}}$$

$$\rightarrow T_{\text{Basic setpoint}} + T_{\text{Deadband}} = T_{\text{Comfort setpoint cooling}}$$

$$\rightarrow T_{\text{Comfort setpoint cooling}} - T_{\text{Comfort setpoint heating}} = T_{\text{Deadband}}$$

$$\rightarrow T_{\text{Comfort setpoint cooling}} \geq T_{\text{Comfort setpoint heating}}$$



### 10.3.1 Operating mode and setpoint parameters

Overwrite setpoints in device during ETS programming operation	Checkbox ( <b>yes</b> / no)
<p>The setpoint temperatures programmed in the room temperature controller by the ETS during commissioning can be changed via communication objects. This parameter can be used to define whether the setpoints present in the device, which may have been changed subsequently, are overwritten during an ETS programming operation and thus replaced again by the values parameterised in the ETS. If this parameter is "Yes", then the setpoint temperatures are deleted in the device during a programming operation and replaced by the values of the ETS. If this parameter is configured to "No", then setpoints present in the device remain unchanged. The setpoint temperatures entered in the ETS then have no significance.</p>	

Setpoint presetting	<b>absolute</b> relative
<p>It is possible to configure the setpoints for the "Comfort", "Standby" and "Night" modes directly (absolute setpoint presetting) or relatively (derivation from basic setpoint). This parameter defines the way the setpoint temperature is preset.</p> <p>With "Relative": All temperature setpoints are derived from the basic temperature (basic setpoint).</p> <p>With "Absolute": The setpoint temperatures are independent of each other. Different temperature values can be specified for each operating mode and heating/cooling mode.</p>	

#### Setpoint temperatures via operating mode for absolute setpoint presetting

##### Heating

Comfort	<b>21.0</b>
<p>With absolute setpoint presetting the setpoint temperatures for Comfort, Standby and Night mode are independent of each other. Depending on the operating mode and heating/cooling mode, various temperature values can be specified in the ETS within the range +7.0 °C to +40.0 °C. The ETS does not validate the temperature values. It is thus possible, for example, to select smaller setpoint temperatures for cooling mode than for heating mode, or to specify lower temperatures for Comfort mode than for Standby mode. After commissioning using the ETS the setpoint temperatures can be changed via the bus by means of temperature telegrams. This can be done using the communication object "Setpoint temperature - Active operating mode".</p> <p>Presetting of the setpoint temperature for the Comfort heating mode.  These parameters are only visible with absolute setpoint presetting!</p>	
Standby	<b>7 ... 19.0 ... 40 °C</b>
Presetting of the setpoint temperature for Standby mode (heating).	
Night	<b>7 ... 17.0 ... 40 °C</b>
Presetting of the setpoint temperature for night mode (heating).	

Frost protection	7.0 ... 40 °C
Presetting of the setpoint temperature for frost protection mode (heating).	

## Cooling

Comfort	7 ... 23.0 ... 40 °C
Presetting of the setpoint temperature for Standby mode (cooling).	

Standby	7 ... 25.0 ... 40 °C
Presetting of the setpoint temperature for Standby mode (cooling).	

Night mode	7 ... 27.0 ... 40 °C
Presetting of the setpoint temperature for night mode (cooling).	

Heat protection	7 ... 35.0 ... 45 °C
Presetting of the setpoint temperature for heat protection mode (cooling).	

Accept change permanently via bus	Checkbox (yes / no)
<p>One has to distinguish between two cases, defined by this parameter, if the setpoint has been modified via the object. This parameter is only visible with absolute setpoint presetting!</p> <p>When "Yes": If, with this setting, the setpoint temperature is adjusted, the controller saves the value permanently to the permanent storage. The newly adjusted value will overwrite the initial value, i.e. the absolute setpoint temperature originally loaded using the ETS. The changed values are also retained after a device reset, after a switchover of the operating mode or after a switchover of the heating/cooling mode (with absolute setpoint specification individually for each operating mode for heating and cooling).</p> <p>When "No": The setpoints received via the object remain active only temporarily. In case of a bus voltage failure, after a switchover to another operating mode (e.g. Comfort to Standby, or also Comfort to Comfort), or after a switchover of the operating mode (e.g. Heating to Cooling), the last setpoint changed will be discarded and replaced by the initial value.</p>	

Difference between basic and additional levels	0 ... 2 ... 12.7 K
<p>In a two stage control mode it is necessary to determine the temperature difference to the basic stage with which the additional stage is to be incorporated into the control. This parameter defines the level spacing.</p> <p>The parameter can only be seen in two-level control operation.</p>	

**Setpoint temperatures via operating mode for relative setpoint presetting**

Basic setpoint temperature	7 ... 21.0 ... 40 °C
<p>This parameter defines the temperature value to be applied as the basic setpoint after commissioning by the ETS. All the temperature setpoints are derived from the basic setpoint.</p> <p>This parameter is only visible with relative setpoint presetting!</p>	

Approve change via bus	Checkbox (yes / no)
Here, it is possible to specify if it is possible to change the basic setpoint via the bus. This parameter is only visible with relative setpoint presetting!	

Accept permanently	Checkbox (yes / no)
In addition to specifying individual setpoint temperatures by the ETS or basic setpoint object, the user can shift the basic setpoint in a specific range via a communication object. Whether a basic setpoint shifting only affects the currently active operating mode or whether it influences all other setpoint temperatures of the remaining operating modes is determined by this parameter.	
In the "yes" setting, the shift of the basic setpoint carried out affects all operating modes. The shift is maintained even after a switchover of the operating mode or the heating/cooling mode or adjusting the basic setpoint.	
In the "no" setting, the basic setpoint shift carried out is in effect for only as long as the operating mode or heating/cooling mode has not changed or the basic setpoint is maintained. Otherwise the setpoint shift will be reset to "0".	
This parameter is only visible with relative setpoint presetting!	

### Temperature shift via operating mode for relative setpoint presetting

#### Heating

Standby	-10...-2...0 K
The value by which the standby setpoint temperature for heating is lowered compared to the heating comfort temperature.	
The parameter is only visible in the "Heating" or "Heating and cooling" operating mode (if necessary with additional levels) and only with relative setpoint presetting.	

Night	-10...-4...0 K
The value by which the night temperature for heating is lowered compared to the heating comfort temperature.	
The parameter is only visible in the "Heating" or "Heating and cooling" operating mode (if necessary with additional levels) and only with relative setpoint presetting.	

Frost protection	7.0 ... 40 °C
This parameter specifies the setpoint temperature for frost protection. The parameter is only visible in "Heating" or "Heating and cooling" operating modes (if necessary with additional levels).	

#### Cooling

Standby	0...20...10 K
The value by which the standby setpoint temperature for cooling is raised compared to the cooling comfort temperature.	
The parameter is only visible in the "Heating" or "Heating and cooling" operating mode (if necessary with additional levels) and only with relative setpoint presetting.	

Night mode	0... <b>4</b> ...10 K
<p>The value by which the night temperature for cooling is raised compared to the cooling comfort temperature.</p> <p>The parameter is only visible in the "Heating" or "Heating and cooling" operating mode (if necessary with additional levels) and only with relative setpoint presetting.</p>	
Heat protection	7 ... <b>35.0</b> ... 45 °C
<p>This parameter specifies the setpoint temperature for heat protection. The parameter is only visible in "Cooling" or "Heating and cooling" operating modes (if necessary with additional levels).</p>	
Difference between basic and additional levels	0... <b>2</b> ...12.7 K
<p>In a two stage control mode it is necessary to determine the temperature difference to the basic stage with which the additional stage is to be incorporated into the control. This parameter defines the level spacing.</p> <p>The parameter can only be seen in two-level control operation.</p>	

### Setpoint temperature shift

Maximum shift upwards	0 K + 1 K + 2 K + 3 K + 4 K + 5 K + 6 K + 7 K + <b>8 K</b> + 9 K + 10 K
<p>This is used to define the maximum range in which the basic setpoint temperature can be adjusted upwards.</p> <p>This parameter is only visible with relative setpoint presetting!</p>	

Maximum shift downwards	0 K - 1 K - 2 K - 3 K - 4 K - 5 K - 6 K - 7 K - 8 K - 9 K - 10 K
This is used to define the maximum range in which the basic setpoint temperature can be adjusted downwards. This parameter is only visible with relative setpoint presetting!	
Type of shift	Via counter value x step width <b>Via relative temperature value</b>
Depending on the setting of the parameter "Type of shift", the shift takes place via a 2-byte communication object (acc. to KNX DPT 9.002) or via a 1-byte communication object (acc. to KNX DPT 6.010). This parameter is only visible with relative setpoint presetting!	
Accept changes permanently via bus	Checkbox (yes / no)
In addition to specifying individual setpoint temperatures by the ETS or basic setpoint object, the user can shift the basic setpoint in a specific range using the sensor buttons or a communication object. Whether a basic setpoint shifting only affects the currently active operating mode or whether it influences all other setpoint temperatures of the remaining operating modes is determined by this parameter. In the "yes" setting, the shift of the basic setpoint carried out affects all operating modes. The shift is maintained even after a switchover of the operating mode or the heating/cooling mode or adjusting the basic setpoint. In the "no" setting, the basic setpoint shift carried out is in effect for only as long as the operating mode or heating/cooling mode has not changed or the basic setpoint is maintained. Otherwise the setpoint shift will be reset to "0".	

### Value adjustment

Step width	0.1 K 0.5 K
<p>This parameter defines the value of a level of the setpoint shift. With a setpoint shift, the basic setpoint (with relative setpoint specification) is changed by the temperature value configured here when there is an adjustment by one step in a positive or negative direction. The controller module rounds the temperature values received via the "Setpoint temperature - Basic value" object and matches the values to the step width configured here.</p> <p>The parameter is only available if the shift has the setting "Via counter value x step width".</p> <p>In combination with the function "Setpoint heating temperature increase", the setpoint temperature can also be modified in smaller steps, even with a step width of 0.5 K.</p>	

### Deadband between heating and cooling

Allocation of deadband	symmetrical asymmetrical
<p>With relative setpoint presetting, the comfort setpoint temperatures for the operating mode "Heating and cooling" are derived from the basic setpoint in consideration of the set deadband. The deadband (temperature zone for which there is neither heating nor cooling) is the difference between the comfort setpoint temperatures.</p> <p>Symmetrical setting: The deadband preset in the ETS plug-in is divided in two parts at the basic setpoint. Based on the resulting half deadband, the comfort setpoint temperatures are derived directly from the basic setpoint (Basic setpoint - 1/2 deadband = Heating comfort temperature or Basic setpoint + 1/2 deadband = Cooling comfort temperature).</p> <p>Asymmetrical setting: With this setting the comfort setpoint temperature for heating equals the basic setpoint! The preset deadband is effective only from the basic setpoint in the direction of comfort temperature for cooling. Thus the comfort set-temperature for cooling is derived directly from the comfort setpoint for heating.</p> <p>The parameter is only visible in the "Heating and cooling" operating mode (if necessary with additional levels) and only with relative setpoint presetting!</p>	
Size	0.1...1...25.5 K
<p>With relative setpoint presetting, the comfort setpoint temperatures for heating and cooling are derived from the basic setpoint in consideration of the set deadband. The deadband (temperature zone for which there is neither heating nor cooling) is the difference between the comfort setpoint temperatures. It is set using this parameter.</p> <p>The parameter is only visible in the "Heating and cooling" operating mode (if necessary with additional levels) and only with relative setpoint presetting.</p>	

**Setpoint temperature transmission behaviour**

on change by	0...0.1...25.5 K
Determines the size of the value change required to transmit the current value automatically to the bus via the "Setpoint temperature" object. In the "0" setting, the setpoint temperature is not transmitted automatically when there is a change.	
Cyclical (0 = inactive)	0...255 min
This parameter determines whether the setpoint temperature is to be transmitted cyclically via the "Setpoint temperature" object. Definition of the cycle time by this parameter. In the "0" setting, the setpoint temperature is not transmitted cyclically.	

**10.3.2 Objects for operating mode and setpoints**

Object no.	Function	Name	Type	DPT	Flag
334, 384, 434, 484, 534, 584, 634, 684, 734, 784, 834, 884	Operating mode - Preset	RTC x - Input	1 bytes	20,102	C, -, W, T, -
1-byte object for change-over of the operating mode of the controller according to the KNX specification. After voltage return or an ETS programming operation, the current operating mode is transmitted via this object.					
Object no.	Function	Name	Type	DPT	Flag
335, 385, 435, 485, 535, 585, 635, 685, 735, 785, 835, 885	Operating mode - Forced	RTC x - Input	1 bytes	20,102	C, -, W, T, U
1-byte object for forced change-over (highest priority) of the operating mode of the controller according to the KNX specification.					



Object no.	Function	Name	Type	DPT	Flag
336, 386, 436, 486, 536, 586, 636, 686, 736, 786, 836, 886	Presence detection - Presence button	RTC x - Input	1-bit	1,001	C, -, W, T, U
<p>1-bit object through which an external presence button (e.g. from a controller extension) can be linked to the controller (polarity: Presence exists = "1", no presence exists = "0").</p> <p>Presence allows permanent switching to Comfort mode (starting in Standby mode) or temporary switching to this comfort extension (starting from Night mode or Frost/heat protection mode).</p> <p>Presence in Standby mode: If there is a presence, the controller activates Comfort mode. As soon as the object no longer signals a presence, the controller switches back to Standby mode.</p> <p>Presence in Night mode or Frost/heat protection mode: If there is a presence, the controller activates the comfort extension. After the configured length of the comfort extension has elapsed, the system automatically switches back to Night mode or Frost/heat protection mode. In this case, the object value is reset automatically.</p> <p>After a mains voltage return or an ETS programming operation (controller reset), the presence function is always inactive.</p> <p>This object is only visible when presence detection is configured to "Presence button".</p>					

Object no.	Function	Name	Type	DPT	Flag
336, 386, 436, 486, 536, 586, 636, 686, 736, 786, 836, 886	Presence detection - Presence object 1	RTC x - Input	1-bit	1,001	C, -, W, -, -
342, 392, 442, 492, 542, 592, 642, 692, 742, 792, 842, 892	Presence detection - Presence object 2	RTC x - Input	1-bit	1,001	C, -, W, -, -

1-bit object through which an external KNX presence detector can be linked to the controller (polarity: Presence exists = "1", no presence exists = "0").

If there is a presence, the controller activates Comfort mode, provided that no higher-level function (e.g. window status) is active. The controller switches to the last specified operating mode as soon as the presence detector ceases to signal a presence.

After a mains voltage return or an ETS programming operation (controller reset), the presence function is always inactive.

These objects are only visible when presence detection is configured to "Presence detector".

Object no.	Function	Name	Type	DPT	Flag
337, 387, 437, 487, 537, 587, 637, 687, 737, 787, 837, 887	Frost/heat protection - Window contact	RTC x - Input	1-bit	1,019	C, -, W, -, U

1-bit object for the coupling of window contacts.

Polarity: Window open = "1", window closed = "0".

Object no.	Function	Name	Type	DPT	Flag
381, 431, 481, 531, 581, 631, 681, 731, 781, 831, 881, 931	Frost protection - Temperature drop - Status	RTC x - Output	1-bit	1,011	C, R, -, T, A

1-bit object to signal a detected temperature drop.

Polarity: temperature drop detected = "1", no temperature drop detected = "0".

Object no.	Function	Name	Type	DPT	Flag
343, 393, 443, 493, 543, 593, 643, 693, 743, 793, 843, 893	Setpoint temperature - Active operating mode - Status	RTC x - Output	2 bytes	9,001	C, R, -, T, A

2-byte object for the output of the current temperature setpoint. Depending on the operating mode, the possible range of values is limited by the configured frost protection and/or heat protection temperature.

The temperature value is always output in the format "°C".

After mains voltage return or an ETS programming operation (controller reset), the current setpoint temperature is transmitted via this object.

Function: absolute setpoint temperature specification

Object no.	Function	Name	Type	DPT	Flag
333, 383, 433, 483, 533, 583, 633, 683, 733, 783, 833, 883	Setpoint temperature - Active operating mode	RTC x - Input	2 bytes	9,001	C, -, W, -, U

2-byte object for external setting of a setpoint for absolute setpoint presetting. Depending on the operating mode, the possible range of values is limited by the configured frost protection and/or heat protection temperature. The controller rounds the temperature values received via the object to 0.1 K.

The temperature value must always be specified in the format "°C".

Function: relative setpoint temperature specification, basic value

Object no.	Function	Name	Type	DPT	Flag
333, 383, 433, 483, 533, 583, 633, 683, 733, 783, 833, 883	Setpoint temperature - Basic value	RTC x - Input	2 bytes	9,001	C, -, W, -, U

2-byte object for external specification of the basic setpoint for relative setpoint specification. Depending on the operating mode, the possible range of values is limited by the configured frost protection and/or heat protection temperature. The controller rounds the temperature values received irrespective of the configured value of the of the setpoint shift (0.1 K or 0.5 K).

The temperature value must always be specified in the format "°C".

Object no.	Function	Name	Type	DPT	Flag
343, 393, 443, 493, 543, 593, 643, 693, 743, 793, 843, 893	Setpoint temperature - Basic value - Status	RTC x - Output	2 bytes	9,001	C, R, -, T, A

2-byte object for the output of the current basic setpoint. Depending on the operating mode, the possible range of values is limited by the configured frost protection and/or heat protection temperature.

The temperature value is always output in the format "°C".

After mains voltage return or an ETS programming operation (controller reset), the current basic setpoint temperature is transmitted via this object.

Function: relative setpoint temperature shift via direct temperature value

Object no.	Function	Name	Type	DPT	Flag
346, 396, 446, 496, 546, 596, 646, 696, 746, 796, 846, 896	Setpoint temperature - Shift	RTC x - Input	2 bytes	9,002	C, -, W, -, U

2-byte object for setting a basic setpoint shifting, e.g. via a controller extension. The value of a counter value in the communication object is dependent on the configured setpoint shift value (0.1 K or 0.5 K). The value "0" means that no shift is active. The value is depicted in a double complement in the positive and negative direction.

In case the limits of the value range are exceeded by the preset external value, the controller will automatically reset the received value to the minimum and maximum limits.

Object no.	Function	Name	Type	DPT	Flag
345, 395, 445, 495, 545, 595, 645, 695, 745, 795, 845, 895	Setpoint temperature - Shift - Status	RTC x - Output	2 bytes	9,002	C, R, -, T, A

2-byte object for giving feedback on the current setpoint shift for evaluation, e.g. by a controller extension. The value "0" means that no shift is active. The value is depicted in a double complement in the positive and negative direction.

After mains voltage return or an ETS programming operation (controller reset), the current value for the basic setpoint shift is transmitted via this object. Since the value for the basic setpoint shift is stored exclusively in volatile memory, the shift is always "0" immediately after a mains voltage return or an ETS programming operation.

Function: relative setpoint temperature shift via counter value x step width

Object no.	Function	Name	Type	DPT	Flag
346, 396, 446, 496, 546, 596, 646, 696, 746, 796, 846, 896	Setpoint temperature - Shift	RTC x - Input	1 bytes	6,010	C, R, -, T, A

1-byte object for setting a basic setpoint shifting, e.g. via a controller extension. The value of a counter value in the communication object is dependent on the configured setpoint shift value (0.1 K or 0.5 K). The value "0" means that no shift is active. The value is depicted in a double complement in the positive and negative direction.

In case the limits of the value range are exceeded by the preset external value, the controller will automatically reset the received value to the minimum and maximum limits.

Object no.	Function	Name	Type	DPT	Flag
345, 395, 445, 495, 545, 595, 645, 695, 745, 795, 845, 895	Setpoint temperature - Shift - Status	RTC x - Output	1 bytes	6,010	C, R, -, T, A

1-byte object for giving feedback on the current setpoint shift for evaluation, e.g. by a controller extension. The value of a counter value in the communication object is dependent on the configured setpoint shift value (0.1 K or 0.5 K). The value "0" means that no shift is active. The value is depicted in a double complement in the positive and negative direction.

After mains voltage return or an ETS programming operation (controller reset), the current value for the basic setpoint shift is transmitted via this object. Since the value for the basic setpoint shift is stored exclusively in volatile memory, the shift is always "0" immediately after a mains voltage return or an ETS programming operation.

## 10.4 Command value output and command value limit

### Automatic transmission

On automatic transmission of the command value telegrams, a distinction is made with regard to the type of control...

- Continuous PI control:

In the case of continuous PI control, the room temperature controller calculates a new command value cyclically every 30 seconds and outputs it to the bus via a 1-byte value object. In so doing, the parameter "On change by (0 = inactive)" in the parameter node "Room temperature controller x -> RTCx - General -> Command value output" can be used to specify the change interval of the command value in percent, according to which a new command value is to be output to the bus. The change interval can be configured to "0" so that a change in the command value will not result in an automatic transmission.

In addition to the command value output following a change, the current command value may be periodically transmitted. In addition to the times when changes are to be expected, other command value telegrams will be output according to the active value after a configurable cycle time. This ensures that, during cyclical security monitoring of the command value in valve drive or in the addressed switch actuator, telegrams are received within the monitoring time. The time interval defined by the parameter "Cyclical (0 = inactive)" should correspond to the monitoring time in the actuator (cycle time in the controller is preferably to be configured smaller). The "0" setting will deactivate the periodic transmission of the command value.

With continuous PI control it must be noted that if the cyclical and the automatic transmission are both deactivated, no command value telegrams will be transmitted in case of a change!

– Switching PI control (PWM):

In case of a switching PI control (PWM), the room temperature controller calculates a new command value internally every 30 seconds. The parameter "PWM cycle time" defines the cycle time of the PWM command value signal.

If the command value is changed, the current PWM cycle is adapted as required so that the duty factor corresponds as directly as possible to the new command value. This adaptation is carried out in the same way as during activation of the valve outputs (see figure 8).

– 2-point feedback control:

In case of a 2-point feedback control, the room temperature and thus the hysteresis values are evaluated periodically every 30 seconds, so that the command values, if required, will change solely during these times. As, with this control algorithm, no continuous command values are calculated, the parameter "On change by (0 = inactive)" has no effect with this control algorithm. In addition to the command value output following a change, the current command value may be periodically transmitted on the bus. In addition to the times when changes are to be expected, other command value telegrams will be output according to the active value after a configurable cycle time. This ensures that, during cyclical security monitoring of the command value in valve drive or in the addressed switch actuator, telegrams are received within the monitoring time. The time interval defined by the parameter "Cyclical (0 = inactive)" should correspond to the monitoring time in the actuator (cycle time in the controller is preferably to be configured smaller). The "0" setting will deactivate the periodic transmission of the command value.

### **Command value limit**

Optionally a command value limit can be configured in the ETS. The command value limit allows the restriction of calculated command values to the range limits "Minimum command value" and "Maximum command value". The limits are permanently set in the ETS and, if command value limitation is active, can be neither undershot or exceeded during device operation. It is possible, if available, to specify various limiting values for the basic and additional stages and for heating and cooling.

The "Activation" parameter on the parameter page "Room temperature controller -> RTCx - General -> Command value limit" defines the type of action of the limiting function. The command value limit can either be activated or deactivated using the 1-bit communication object "Command value limit", or be permanently active. When controlling via the object, it is possible to have the controller activate the command value limit automatically after bus voltage return or an ETS programming operation. Here, the "Active after reset" parameter defines the initialisation behaviour. In the "no" setting, the command value limit is not automatically activated after a device reset. A "1" telegram must first be received via the "Command value limit" object for the limit to be activated. In the "yes" setting, the controller activates the command value limit automatically after a device reset. To deactivate the limit a "0" telegram must be received via the "Command value limit - Activate / Deactivate" object. The limit can be switched on or off at any time using the object. With a permanently active command value limit, the initialisation behaviour cannot be configured separately after a device reset, as the limit is always active. In this case it is also not possible to configure any object.

As soon as the command value limit is active, calculated command values are limited according to the limiting values from the ETS. The behaviour with regard to the minimum or maximum command value is then as follows...

- Minimum command value:  
The "Minimum command value" parameter specifies the lower command value limiting value. The setting can be made in 5% increments in the range 5% ... 50%. With an active command value limit, the set minimum command value is not undershot by command values. If the controller calculates smaller command values, it sets the configured minimum command value. The controller transmits a 0% command value if no more heating or cooling energy has to be demanded.
- Maximum command value:  
The "Maximum command value" parameter specifies the upper command value limiting value. The setting can be made in 5% increments in the range 55% ... 100%. With an active command value limit, the set maximum command value is not exceeded. If the controller calculates larger command values, it sets the configured maximum command value.

If the limit is removed, the device automatically repositions the most recently calculated command value to the unlimited values when the next calculation interval for the command values (30 seconds) has elapsed.

-  An active command value limit has a negative effect on the control result when the command value range is very restricted. A control deviation must be expected.

### **Special case for command value 100% (Clipping mode)**

If with a PI control the calculated command value of the controller exceeds the physical limits of the actuator, in other words if the calculated command value is greater than 100%, then the command value is set to the maximum value (100%) and thus limited. This special, necessary control behaviour is also called "clipping". With PI control the command value can reach the value "100%" if there is a large deviation of



the room temperature from the setpoint temperature or the controller requires a long time to adjust to the setpoint with the heating or cooling energy that is being applied. The controller evaluates this state in a particular manner.

The controller maintains the maximum command value only as long as it is necessary. After that it adjusts the command value downwards according to the PI algorithm. The advantage of this control characteristic is the fact that the room temperature does not exceed the setpoint temperature at all, or only slightly. It should be mentioned that this necessary control principle increases the tendency to oscillate about the setpoint.

- i** Clipping may also occur when a command value limit is active (maximum command value). In this case, if the internally calculated command value reaches 100%, then the controller only transmits to the bus the maximum command value according to the ETS configuration.

### 10.4.1 Command value output parameters

#### Command value output

PWM cycle time	1 ... 15 ... 255 min
This parameter specifies the cycle time for the pulse width modulated command value (PWM).	

#### Polarity of the command values

Heating	<b>normal (under current, this means opened)</b> inverted (under current, this means closed)
---------	---

At this point, it is possible to specify whether the command value telegram for heating is output normally or in inverted form. This parameter is only visible if the operating mode "Heating" or "Heating and cooling" is configured and not two-level operation.

Basic level heating	<b>normal (under current, this means opened)</b> inverted (under current, this means closed)
---------------------	---

At this point, it is possible to specify whether the command value telegram for the basic level heating is output normally or in inverted form. This parameter is only visible if the operating mode "Heating" or "Heating and cooling" is configured along with two-level operation.

Additional level heating	<p><b>normal (under current, this means opened)</b></p> <p>inverted (under current, this means closed)</p>
<p>At this point, it is possible to specify whether the command value telegram for the additional level heating is output normally or in inverted form. This parameter is only visible if the operating mode "Heating" or "Heating and cooling" is configured along with two-level operation.</p>	

Cooling	<p><b>normal (under current, this means opened)</b></p> <p>inverted (under current, this means closed)</p>
<p>At this point, it is possible to specify whether the command value telegram for cooling is output normally or in inverted form. This parameter is only visible if the operating mode "Cooling" or "Heating and cooling" is configured and not two-level operation.</p>	

Basic level cooling	<p><b>normal (under current, this means opened)</b></p> <p>inverted (under current, this means closed)</p>
<p>At this point, it is possible to specify whether the command value telegram for the basic level cooling is output normally or in inverted form. This parameter is only visible if the operating mode "Cooling" or "Heating and cooling" is configured along with two-level operation.</p>	

Additional level cooling	<p><b>normal (under current, this means opened)</b></p> <p>inverted (under current, this means closed)</p>
<p>At this point, it is possible to specify whether the command value telegram for the additional level cooling is output normally or in inverted form. This parameter is only visible if the operating mode "Cooling" or "Heating and cooling" is configured along with two-level operation.</p>	

**Transmission behaviour**

On change by (0 = inactive)	0... <b>3</b> ...100 %
<p>This parameter determines the size of the command value change that will automatically transmit continuous command value telegrams via the command value objects. Thus this parameter only affects command values which are configured to "Continuous PI control" and to the 1 byte additional command value objects of the "Switching PI control (PWM)".</p>	

Cyclical	0...10...255 min
This parameter determines the time interval for the cyclical transmission of the command values via all command value objects.	

### 10.4.2 Command value limit parameters

Activation	via object permanently active
<p>The command value limit allows the restriction of calculated command values to the range limits "minimum" and "maximum". The limits are permanently set in the ETS and, if command value limitation is active, can be neither undershot or exceeded during device operation.</p> <p>The "Activation" parameter defines the type of action of the limiting function. The command value limit can either be activated or deactivated using the 1-bit communication object "Command value limit - Activate / Deactivate" or be permanently active.</p>	

Active after reset	Checkbox (yes / no)
<p>When controlling via the object, it is possible to have the controller activate the command value limit automatically after bus voltage return or an ETS programming operation. This parameter defines the initialisation behaviour here.</p> <p>In the "Deactivated" setting, the command value limit is not automatically activated after a device reset. A "1" telegram must first be received via the "Command value limit - Activate/Deactivate" object for the limit to be activated.</p> <p>In the "Activated" setting, the controller activates the command value limit automatically after a device reset. To deactivate the limit a "0" telegram must be received via the "Command value limit - Activate / Deactivate" object. The limit can be switched on or off at any time using the object.</p> <p>This parameter is only visible if the command value limit can be activated via object.</p>	

#### Heating (also for basic level or additional level)

Minimum command value for heating	5%, 10%, 15%, 20%, 25%, 30%, 35%, 40%, 45%, 50%
<p>The "Minimum command value" parameter specifies the lower command value limiting value for heating. With an active command value limit, the set minimum command value is not undershot by command values. If the controller calculates smaller command values, it sets the configured minimum command value. The controller transmits a 0% command value if no more heating or cooling energy has to be demanded.</p>	

Maximum command value	55%, 60%, 65%, 70%, 75%, 80%, 85%, 90%, 95%, 100%
<p>The "Maximum command value" parameter specifies the upper command value limiting value for heating. With an active command value limit, the set maximum command value is not exceeded. If the controller calculates larger command values, it sets the configured maximum command value.</p>	

**Cooling (also for basic level or additional level)**

Minimum command value	5%, 10%, 15%, 20%, 25%, 30%, 35%, 40%, 45%, 50%
-----------------------	---

The "Minimum command value" parameter specifies the lower command value limiting value for cooling. With an active command value limit, the set minimum command value is not undershot by command values. If the controller calculates smaller command values, it sets the configured minimum command value. The controller transmits a 0% command value if no more heating or cooling energy has to be demanded.

Maximum command value	55%, 60%, 65%, 70%, 75%, 80%, 85%, 90%, 95%, 100%
-----------------------	---

The "Maximum command value" parameter specifies the upper command value limiting value for cooling. With an active command value limit, the set maximum command value is not exceeded. If the controller calculates larger command values, it sets the configured maximum command value.

**10.4.3 Objects for command value output and command value limit**

**Object for heating command value output and combined valve heating/cooling**

Function: Command value

Object no.	Function	Name	Type	DPT	Flag
935, 977, 1019, 1061, 1103, 1145, 1187, 1229, 1271, 1313, 1355, 1397	Command value - Heating / Command value basic level heating	RTC x - Output	1 bytes	5,001	C, (R), -, T, -
966, 1008, 1050, 1092, 1134, 1176, 1218, 1260, 1302, 1344, 1386, 1428 *	Command value - Heating / Command value basic level heating	RTC x - Output	1 bytes	5,001	C, (R), -, T, -

1-byte object to output the continuous command value of the heating mode. In two-level heating mode, command value output for the basic heating. This object is only available in this way if the type of feedback control is configured to "Continuous PI control".

\* These objects are only visible if, with combined heating/cooling command value, separate command value objects are also displayed.

Function: Command value

Object no.	Function	Name	Type	DPT	Flag
935, 977, 1019, 1061, 1103, 1145, 1187, 1229, 1271, 1313, 1355, 1397	Command value - Heating / Command value basic level heating	RTC x - Output	1-bit	1,001	C, (R), -, T, -
966, 1008, 1050, 1092, 1134, 1176, 1218, 1260, 1302, 1344, 1386, 1428 *	Command value - Heating / Command value basic level heating	RTC x - Output	1-bit	1,001	C, (R), -, T, -
<p>1-bit object to output the PWM command value of the heating mode. In two-level heating mode, command value output for the basic heating. This object is only available in this way if the type of feedback control is configured to "Switching PI control (PWM)".</p> <p>* These objects are only visible if, with combined heating/cooling command value, separate command value objects are also displayed.</p>					

Object no.	Function	Name	Type	DPT	Flag
939, 981, 1023, 1065, 1107, 1149, 1191, 1233, 1275, 1317, 1359, 1401	Command value - Heating - Status / Command value basic level heating - Status	RTC x - Output	1 bytes	5,001	C, (R), -, T, -
970, 1012, 1054, 1096, 1180, 1222, 1264, 1306, 1348, 1390, 1432 *	Command value - Heating - Status / Command value basic level heating - Status	RTC x - Output	1 bytes	5,001	C, (R), -, T, -
<p>1-byte object for additional continuous output for the PWM command value of the heating mode. In two-level heating mode, command value output for the basic heating. This object is only available in this way if the type of feedback control is configured to "Switching PI control (PWM)".</p> <p>* These objects are only visible if, with combined heating/cooling command value, separate command value objects are also displayed.</p>					

Function: Command value

Object no.	Function	Name	Type	DPT	Flag
935, 977, 1019, 1061, 1103, 1145, 1187, 1229, 1271, 1313, 1355, 1397	Command value - Heating / Command value, basic heating	RTC x - Output	1-bit	1,001	C, (R), -, T, -
966, 1008, 1050, 1092, 1134, 1176, 1218, 1260, 1302, 1344, 1386, 1428 *	Command value - Heating / Command value, basic heating	RTC x - Output	1-bit	1,001	C, (R), -, T, -

1-bit object to output the switching command value of the heating mode. In two-level heating mode, command value output for the basic heating. This object is only available in this way if the type of feedback control is configured to "Switching 2-point feedback control".

\* These objects are only visible if, with combined heating/cooling command value, separate command value objects are also displayed.

Function: Command value

Object no.	Function	Name	Type	DPT	Flag
935, 977, 1019, 1061, 1103, 1145, 1187, 1229, 1271, 1313, 1355, 1397	Command value - Heating/Cooling / Command value basic level heating/cooling	RTC x - Output	1 bytes	5,001	C, (R), -, T, -

1-byte object to output the combined continuous command value of the heating and cooling mode. In two-level heating/cooling mode, command value output for the basic level. This object is only available in this way if the command values for heating and cooling mode are output to a shared object (parameter-dependent). The type of feedback control must also be configured to "Continuous PI control".

Function: Command value

Object no.	Function	Name	Type	DPT	Flag
935, 977, 1019, 1061, 1103, 1145, 1187, 1229, 1271, 1313, 1355, 1397	Command value - Heating/Cooling / Command value basic level heating/cooling	RTC x - Output	1-bit	1,001	C, (R), -, T, -
<p>1-bit object to output the combined PWM command value of the heating and cooling mode. In two-level heating/cooling mode, command value output for the basic level. This object is only available in this way if the command values for heating and cooling mode are output to a shared object (parameter-dependent). The type of feedback control must also be configured to "Switching PI control (PWM)".</p>					

Object no.	Function	Name	Type	DPT	Flag
939, 981, 1023, 1065, 1107, 1149, 1191, 1233, 1275, 1317, 1359, 1401	Command value - Heating/Cooling - Status / Command value basic level heating/cooling - Status	RTC x - Output	1 bytes	5,001	C, (R), -, T, -
<p>1-byte object for additional continuous output for the PWM command value of the heating and cooling mode. In two-level heating and cooling mode, command value output for basic heating / basic cooling. This object is only available in this way if the type of feedback control is configured to "Switching PI control (PWM)".</p>					

Function: Command value

Object no.	Function	Name	Type	DPT	Flag
935, 977, 1019, 1061, 1103, 1145, 1187, 1229, 1271, 1313, 1355, 1397	Command value - Heating/Cooling / Command value basic level heating/cooling	RTC x - Output	1-bit	1,001	C, (R), -, T, -
<p>1-bit object to output the combined switching command value of the heating and cooling mode. In two-level heating/cooling mode, command value output for the basic level. This object is only available in this way if the command values for heating and cooling mode are output to a shared object (parameter-dependent). The type of feedback control must also be configured to "Switching 2-point feedback control".</p>					

**Object for command value output, additional heating and combined valve additional heating/cooling**

Function: Command value



Object no.	Function	Name	Type	DPT	Flag
936, 978, 1020, 1062, 1104, 1146, 1188, 1230, 1272, 1314, 1356, 1398	Command value - Additional level heating	RTC x - Output	1 bytes	5,001	C, (R), -, T, -
967, 1009, 1051, 1093, 1135, 1177, 1219, 1261, 1345, 1387, 1429 *	Command value - Additional level heating	RTC x - Output	1 bytes	5,001	C, (R), -, T, -

1-byte object to output the continuous command value for additional heating in two-level operation. This object is only available in this way if the type of feedback control is configured to "Continuous PI control".

\* These objects are only visible if, with combined heating/cooling command value, separate command value objects are also displayed.

Function: Command value

Object no.	Function	Name	Type	DPT	Flag
936, 978, 1020, 1062, 1104, 1146, 1188, 1230, 1272, 1314, 1356, 1398	Command value - Additional level heating	RTC x - Output	1-bit	1,001	C, (R), -, T, -
967, 1009, 1051, 1093, 1135, 1177, 1219, 1261, 1345, 1387, 1429 *	Command value - Additional level heating	RTC x - Output	1-bit	1,001	C, (R), -, T, -

1-bit object to output the continuous PWM command value for additional heating in two-level operation. This object is only available in this way if the type of feedback control is configured to "Switching PI control (PWM)".

\* These objects are only visible if, with combined heating/cooling command value, separate command value objects are also displayed.

Object no.	Function	Name	Type	DPT	Flag
940, 982, 1024, 1066, 1108, 1150, 1192, 1234, 1276, 1318, 1360, 1402	Command value - Additional level heating - Status	RTC x - Output	1 bytes	5,001	C, (R), -, T, -
971, 1013, 1055, 1097, 1139, 1181, 1223, 1265, 1307, 1349, 1391, 1433 *	Command value - Additional level heating - Status	RTC x - Output	1 bytes	5,001	C, (R), -, T, -

1-bit object for additional continuous output for the PWM command value for additional heating in two-level operation. This object is only available in this way if the type of feedback control is configured to "Switching PI control (PWM)".

\* These objects are only visible if, with combined heating/cooling command value, separate command value objects are also displayed.

Function: Command value

Object no.	Function	Name	Type	DPT	Flag
936, 978, 1020, 1062, 1104, 1146, 1188, 1230, 1272, 1314, 1356, 1398	Command value - Additional level heating	RTC x - Output	1-bit	1,001	C, (R), -, T, -
967, 1009, 1051, 1093, 1135, 1177, 1219, 1261, 1345, 1387, 1429 *	Command value - Additional level heating	RTC x - Output	1-bit	1,001	C, (R), -, T, -

1-bit object to output the switching command value for additional heating in two-level operation. This object is only available in this way if the type of feedback control is configured to "Switching 2-point feedback control".

Function: Command value

Object no.	Function	Name	Type	DPT	Flag
936, 978, 1020, 1062, 1104, 1146, 1188, 1230, 1272, 1314, 1356, 1398	Command value - Additional level heating/cooling	RTC x - Output	1 bytes	5,001	C, (R), -, T, -
<p>1-byte object to output the combined continuous command value for additional level in two-level operation. This object is only available in this way if the command values for heating and cooling mode are output to a shared object (parameter-dependent). The type of feedback control must also be configured to "Continuous PI control".</p>					

Function: Command value

Object no.	Function	Name	Type	DPT	Flag
936, 978, 1020, 1062, 1104, 1146, 1188, 1230, 1272, 1314, 1356, 1398	Command value - Additional level heating/cooling	RTC x - Output	1-bit	1,001	C, (R), -, T, -
<p>1-bit object to output the combined switching PWM command value for additional level in two-level operation. This object is only available in this way if the command values for heating and cooling mode are output to a shared object (parameter-dependent). The type of feedback control must also be configured to "Switching PI control (PWM)".</p>					

Object no.	Function	Name	Type	DPT	Flag
940, 982, 1024, 1066, 1108, 1150, 1192, 1234, 1276, 1318, 1360, 1402	Command value - Additional level heating/cooling - Status	RTC x - Output	1 bytes	5,001	C, (R), -, T, -
<p>1-bit object for additional continuous output of the combined command value for additional level in two-level operation. This object is only available in this way if the command values for heating and cooling mode are output to a shared object (parameter-dependent). The type of feedback control must also be configured to "Switching PI control (PWM)".</p>					

Function: Command value

Object no.	Function	Name	Type	DPT	Flag
936, 978, 1020, 1062, 1104, 1146, 1188, 1230, 1272, 1314, 1356, 1398	Command value - Additional level heating/cooling	RTC x - Output	1-bit	1,001	C, (R), -, T, -
<p>1-bit object to output the combined switching command value for additional level in two-level operation. This object is only available in this way if the command values for heating and cooling mode are output to a shared object (parameter-dependent). The type of feedback control must also be configured to "Switching 2-point feedback control".</p>					

**Object for command value output, cooling**

Function: Command value

Object no.	Function	Name	Type	DPT	Flag
937, 979, 1021, 1063, 1105, 1147, 1189, 1231, 1273, 1315, 1357, 1399	Command value - Cooling / Command value basic level cooling	RTC x - Output	1 bytes	5,001	C, (R), -, T, -
968, 1010, 1052, 1094, 1136, 1178, 1262, 1304, 1346, 1388, 1430 *	Command value - Cooling / Command value basic level cooling	RTC x - Output	1 bytes	5,001	C, (R), -, T, -
<p>1-byte object to output the continuous command value of the cooling mode. In two-level cooling mode, command value output for the basic cooling. This object is only available in this way if the type of feedback control is configured to "Continuous PI control".</p> <p>* These objects are only visible if, with combined heating/cooling command value, separate command value objects are also displayed.</p>					

Function: Command value

Object no.	Function	Name	Type	DPT	Flag
937, 979, 1021, 1063, 1105, 1147, 1189, 1231, 1273, 1315, 1357, 1399	Command value - Cooling / Command value basic level cooling	RTC x - Output	1-bit	1,001	C, (R), -, T, -
968, 1010, 1052, 1094, 1136, 1178, 1262, 1304, 1346, 1388, 1430 *	Command value - Cooling / Command value basic level cooling	RTC x - Output	1-bit	1,001	C, (R), -, T, -

1-bit object to output the PWM command value of the cooling mode. In two-level cooling mode, command value output for the basic cooling. This object is only available in this way if the type of feedback control is configured to "Switching PI control (PWM)".

\* These objects are only visible if, with combined heating/cooling command value, separate command value objects are also displayed.

Object no.	Function	Name	Type	DPT	Flag
941, 983, 1025, 1067, 1109, 1151, 1193, 1235, 1277, 1319, 1361, 1403	Command value - Cooling - Status / Command value basic level cooling - Status	RTC x - Output	1 bytes	5,001	C, (R), -, T, -
972, 1014, 1056, 1098, 1140, 1182, 1224, 1266, 1308, 1350, 1392, 1434 *	Command value - Cooling - Status / Command value basic level cooling - Status	RTC x - Output	1 bytes	5,001	C, (R), -, T, -

1-bit object for additional continuous output of the PWM command value of the cooling mode. In two-level cooling mode, command value output for the basic cooling. This object is only available in this way if the type of feedback control is configured to "Switching PI control (PWM)".

\* These objects are only visible if, with combined heating/cooling command value, separate command value objects are also displayed.

Function: Command value

Object no.	Function	Name	Type	DPT	Flag
937, 979, 1021, 1063, 1105, 1147, 1189, 1231, 1273, 1315, 1357, 1399	Command value - Cooling / Command value basic level cooling	RTC x - Output	1-bit	1,001	C, (R), -, T, -
968, 1010, 1052, 1094, 1136, 1178, 1262, 1304, 1346, 1388, 1430 *	Command value - Cooling / Command value basic level cooling	RTC x - Output	1-bit	1,001	C, (R), -, T, -

1-bit object to output the switching command value of the cooling mode. In two-level cooling mode, command value output for the basic cooling. This object is only available in this way if the type of feedback control is configured to "Switching 2-point feedback control".

\* These objects are only visible if, with combined heating/cooling command value, separate command value objects are also displayed.

**Object for command value output, additional cooling**

Function: Command value

Object no.	Function	Name	Type	DPT	Flag
938, 980, 1022, 1064, 1106, 1148, 1190, 1232, 1274, 1316, 1358, 1400	Command value - Additional level cooling	RTC x - Output	1 bytes	5,001	C, (R), -, T, -
969, 1011, 1053, 1095, 1137, 1179, 1221, 1263, 1305, 1347, 1389, 1431 *	Command value - Additional level cooling	RTC x - Output	1 bytes	5,001	C, (R), -, T, -

1-byte object to output the continuous command value for additional cooling in two-level operation. This object is only available in this way if the type of feedback control is configured to "Continuous PI control".

\* These objects are only visible if, with combined heating/cooling command value, separate command value objects are also displayed.

Function: Command value

Object no.	Function	Name	Type	DPT	Flag
938, 980, 1022, 1064, 1106, 1148, 1190, 1232, 1274, 1316, 1358, 1400	Command value - Additional level cooling	RTC x - Output	1-bit	1,001	C, (R), -, T, -
969, 1011, 1053, 1095, 1137, 1179, 1221, 1263, 1305, 1347, 1389, 1431 *	Command value - Additional level cooling	RTC x - Output	1-bit	1,001	C, (R), -, T, -

1-bit object to output the continuous PWM command value for additional cooling in two-level operation. This object is only available in this way if the type of feedback control is configured to "Switching PI control (PWM)".

\* These objects are only visible if, with combined heating/cooling command value, separate command value objects are also displayed.

Object no.	Function	Name	Type	DPT	Flag
942, 984, 1026, 1068, 1110, 1152, 1194, 1236, 1278, 1320, 1362, 1404	Command value - Additional level cooling - Status	RTC x - Output	1 bytes	5,001	C, (R), -, T, -
973, 1015, 1057, 1099, 1141, 1183, 1225, 1267, 1309, 1351, 1393, 1435 *	Command value - Additional level cooling - Status	RTC x - Output	1 bytes	5,001	C, (R), -, T, -

1-byte object for additional continuous output of the PWM command value for additional cooling in two-level operation. This object is only available in this way if the type of feedback control is configured to "Switching PI control (PWM)".

\* These objects are only visible if, with combined heating/cooling command value, separate command value objects are also displayed.

Function: Command value



Object no.	Function	Name	Type	DPT	Flag
938, 980, 1022, 1064, 1106, 1148, 1190, 1232, 1274, 1316, 1358, 1400	Command value - Additional level cooling	RTC x - Output	1-bit	1,001	C, (R), -, T, -
969, 1011, 1053, 1095, 1137, 1179, 1221, 1263, 1305, 1347, 1389, 1431 *	Command value - Additional level cooling	RTC x - Output	1-bit	1,001	C, (R), -, T, -
<p>1-bit object to output the switching command value for additional cooling in two-level operation. This object is only available in this way if the type of feedback control is configured to "Switching 2-point feedback control".</p> <p>* These objects are only visible if, with combined heating/cooling command value, separate command value objects are also displayed.</p>					

#### 10.4.4 Objects for command value limit

Object no.	Function	Name	Type	DPT	Flag
943, 985, 1027, 1069, 1111, 1153, 1195, 1237, 1279, 1321, 1363, 1405	Command value limit - Activate / De- activate	RTC x - Input	1-bit	1,001	C, -, W, -, U
<p>1-bit object for activating or deactivating the command value limit.</p>					

### 10.5 Room temperature measurement

#### Basic principles

The controller detects the room temperatures using one or possibly two external KNX temperature sensors (e.g. push-button sensors with temperature measurement). Temperature detection is configured on the parameter page "Room temperature controller -> RTCx - General -> Room temperature measurement". Depending on the configuration, the 2-byte objects "Room temperature - Measured value 1" and optionally, the additional "Room temperature - Measured value 2", are enabled.

**i** According to KNX DPT 9.001, the temperature values must be made available to the controller in the format "°C".

When choosing the mounting location of the external temperature sensor, the following points must be considered...

- The temperature sensor should not be used in multiple combinations, especially together with flush-mounted dimmers.
- Do not install the temperature sensor in the area of large electrical consumers (avoid heat influences).
- The push button sensor should not be installed in the vicinity of radiators or cooling systems.
- The temperature sensor should not be exposed to direct sun.
- The installation of sensors on the inside of an outside wall might have a negative impact on the temperature measurement.
- Temperature sensors should be installed at least 30 cm away from doors, windows or ventilation devices and at least 1.5 m above the floor.

### Temperature detection and measured value formation

The "Temperature detection of the room controller by" parameter in the parameter node "Room temperature controller -> RTCx - General -> RTCx - Room temperature measurement" specifies how many external KNX sensors detect the room temperature. The following settings are possible for temperature detection...

- "Temperature input 1"  
The actual temperature is determined solely via an external temperature value. In this case, the KNX temperature sensor is connected to the controller via the 2-byte object "Room temperature - Measured value 1".  
The controller can request the current temperature value cyclically. For this purpose, the parameter "Cyclical polling of the temperature values" must be set to a value > "0". The request interval can be configured within the limits of 1 minute to 255 minutes.  
After a device reset, the controller will first wait for a valid temperature telegram until the feedback control starts and a command value, if applicable, is output.
- "Temperature input 1 and 2"  
The actual temperature is determined using two external temperature values. The selected temperature sources are combined. In this case, the KNX temperature sensors are connected to the controller via the two 2-byte objects "Room temperature - Measured value 1" and "Room temperature - Measured value 2".  
When evaluating, the real actual temperature is made up of the two temperature values provided. The weighting of the temperature values is defined by the parameter "Weighting of temperature inputs 1 and 2". Depending on the different locations of the sensors or non-uniform heat distribution inside the room, it is thus possible to adjust the actual temperature measurement. Temperature sensors that are subject to negative external influences (for example, unfavourable location because of exposure to sun or radiator or door/window in the immediate vicinity) are often weighted less heavily.

Example: A temperature sensor has been installed next to the entrance door. An additional temperature sensor has been mounted on an inner wall in the middle of the room below the ceiling.

Sensor 1: 21.5 °C

Sensor 2: 22.3 °C

Determination of measured value: 30% to 70%

$$\rightarrow T_{\text{Result 1}} = T_1 = 21.5 \text{ °C} \cdot 0.3 = 6.45 \text{ °C},$$

$$\rightarrow T_{\text{Result 2}} = T_2 = 22.3 \text{ °C} \cdot 0.7 = 15.61 \text{ °C}$$

$$\rightarrow T_{\text{Result}} = T_{\text{Result 1}} + T_{\text{Result 2}} = \underline{22.06 \text{ °C}}$$

The controller can request both current temperature values cyclically. For this purpose, the parameter "Polling time of the temperature values" must be set to a value > "0". The request interval can be configured within the limits of 1 minute to 255 minutes.

After a device reset, the controller will first wait for valid temperature telegrams to both objects until control starts and a command value, if applicable, is output.

### Calibrating the measured values

In some cases during room temperature measurement, it may be necessary to adjust the external KNX temperature values. Adjustment becomes necessary, for example, if the temperature measured by the sensors stays permanently below or above the actual temperature in the vicinity of the sensor. To determine the temperature deviation, the actual room temperature should be detected with a reference measurement using a calibrated temperature measuring device.

Using the parameters "Adjust temperature input 1 by" and "Adjust temperature input 2 by", it is possible to configure the positive (temperature increase, factors: 1 ... 127) or negative (temperature decrease, factors -128... -1) temperature calibration in levels of 0.1 K. Thus, the calibration is made only once statically and is the same for all operating modes of the controller.

- i** The measured value has to be increased, if the value measured by the sensor lies below the actual room temperature. The measured value has to be decreased, if the value measured by the sensor lies above the actual room temperature.
- i** During room temperature control, the device always uses the adjusted temperature value to calculate the command values. The adjusted temperature value is transmitted to the bus via the "Room temperature - Actual value - Status" object. When determining the measured value using both external sensors, the calibrated values are also used to calculate the actual value.
- i** Temperature adjustment only affects the room temperature measurement.

### Transmission of the actual temperature

The determined actual temperature can be actively transmitted to the bus via the 2-byte object "Room temperature - Actual value - Status". Parameter "On change by (0 = inactive)" specifies the temperature value by which the actual value has to change in order to have the actual temperature value automatically transmitted via

the object. Possible temperature value changes lie within a range of 0.1 K and 25.5 K. Setting to "0" at this point will deactivate the automatic transmission of the actual temperature.

In addition, the actual value can be transmitted periodically. The parameter "Cyclical (0 = inactive)" specifies the cycle time (1 to 255 minutes). The value "0" will deactivate the periodical transmission of the actual temperature value. If the "Read" flag is set on the "Actual temperature" object, this makes it possible to read out the current actual value at any time over the bus. It has to be pointed out that with deactivated periodical transmission and deactivated automatic transmission, no more actual-temperature telegrams will be transmitted".

Following the return of bus voltage or after programming via the ETS, the object value will be updated according to the current actual temperature value and transmitted as soon as all the external temperature values of the KNX sensors have been received. If no external temperature values have been received after a reset, then the value "0" will be seen in the "Actual temperature" object. For this reason, all the external temperature sensors should always transmit their current measured temperature value after a reset.

During room temperature control, the controller always uses the calibrated temperature values to calculate the command values. The calibrated temperature values can be actively transmitted to the bus via the "Actual temperature" object.

### **Monitoring the actual temperature**

The cyclical actual temperature monitoring can be activated or deactivated via parameter. The parameter "Cyclical monitoring of the temperature inputs" on the parameter page "Room temperature controller -> RTCx - General -> Room temperature measurement" activates or deactivates this function. When cyclical actual temperature monitoring is active, the device cyclically checks whether the configured input objects "Room temperature - Measured value 1" and "Room temperature - Measured value 2" have received new values. The cycle time can be configured by parameter and applies equally to all temperature inputs.

If the value is not updated within the cycle time on one of the configured temperature sensors, the controller signals this error via the KNX-compliant controller status RHCC. Correspondingly, bit 0 ("0" = No error / "1" = Error) of the status telegram (object "Controller status RHCC - KNX-compliant") can be evaluated.

The controller remains active even when no input temperature values are received. The basic levels and the additional levels work with the last received temperature value and continue outputting command values.

The error status is cancelled when all configured temperature inputs are updated within a cycle period. Then the status telegram is also updated and transmitted.

## 10.5.1 Temperature measurement parameters

### Room temperature measurement

Room temperature source	Temperature input 1 Temperature input 1 and 2
<p>The controller detects the room temperatures using one or possibly two external KNX temperature sensors (e.g. push-button sensors with temperature measurement). Depending on the configuration, the 2-byte objects "Room temperature - Measured value 1" and, optionally, the additional "Room temperature - Measured value 2", are enabled. After a device reset, the controller will first wait for valid temperature telegrams to both objects until control starts and a command value, if applicable, is output.</p> <p>Setting "Temperature input 1": The actual temperature is determined solely via an external temperature value. In this case, the KNX temperature sensor is connected to the controller via the 2-byte object "Room temperature - Measured value 1".</p> <p>Setting "Temperature input 1 and 2": The actual temperature is determined using two external temperature values. The selected temperature sources are combined. In this case, the KNX temperature sensors are connected to the controller via the two 2-byte objects "Room temperature - Measured value 1" and "Room temperature - Measured value 2".</p>	
Weighting of temp. inputs 1 and 2	10% to 90% 20% to 80% 30% to 70% 40% to 60% <b>50% to 50%</b> 60% to 40% 70% to 30% 80% to 20% 90% to 10%
<p>The weighting of the temperature values of the two external KNX temperature sensors is specified here. That results in an overall value, which will be used for the further interpretation of the room temperature.</p> <p>This parameter is only visible when the temperature detection system requires two external temperature sensors.</p>	
Cyclical monitoring of the temperature values	Checkbox (yes / no)
<p>Here, cyclical monitoring of the temperature values can be enabled as an option ("yes" setting). If, during active cyclical monitoring, there are no temperature values during the cycle time defined by the parameter of the same name, emergency operation will be activated.</p>	
Cycle time	1 ... 10... 255
<p>The polling time for the external temperature value(s) is specified here.</p>	

Cycle time	0 ... 4 h 1 ... 20 ... 59 min
Presetting of the monitoring time hours and minutes.	

Cyclical polling of the temperature values	Checkbox (yes / no)
This setting determines whether the controller polls the temperature value(s) cyclically. In the "no" setting, the temperature value is not automatically polled by the controller. In this case the communication partner (e.g. controller extension) must transmit its temperature value itself.	

Cycle time	1 ... 10... 255
The polling time for the external temperature value(s) is specified here.	

### Temperature calibration

Adjust temperature input 1 by	-12.8...0...12.7 K
Specifies the value by which the room temperature measured value of the first external KNX temperature sensor is adjusted.	

Adjust temperature input 2 by	-12.8...0...12.7 K
Specifies the value by which the room temperature measured value of the second external KNX temperature sensor is adjusted.	

### Room temperature transmission behaviour

On change by (0 = inactive)	0...0.5...25.5 K
This parameter specifies the temperature value by which the actual value has to change in order to have the actual temperature value transmitted automatically via the object. The "0" setting deactivates the automatic transmission of the actual temperature.	

Cyclical (0 = inactive)	0...15...255 min
This parameter specifies whether and when the determined room temperature is output cyclically via the "Actual temperature" object.	

## 10.5.2 Objects for temperature measurement

Object no.	Function	Name	Type	DPT	Flag
1437, 1447, 1457, 1467, 1477, 1487, 1497, 1507, 1517, 1527, 1537, 1547	Room temperature - Actual value - Status	RTC x - Output	2 bytes	9,001	C, R, -, T, -

2-byte object for the display of the actual temperature active in the controller (room temperature). The possible temperature range is specified by the received temperature values and corresponds to the range specified by the KNX DPT 9.001.

The temperature value is always output in the format "°C".

Object no.	Function	Name	Type	DPT	Flag
1438, 1448, 1458, 1468, 1478, 1488, 1498, 1508, 1518, 1528, 1538, 1548	Room temperature - Measured value 1	RTC x - Input	2 bytes	9,001	C, -, W, T, U

2-byte object for coupling an external KNX temperature sensor (e.g. push-button sensor with temperature measurement) for room temperature detection. The possible temperature range is specified by the KNX DPT 9.001.

The temperature value must always be specified in the format "°C".

Object no.	Function	Name	Type	DPT	Flag
1439, 1449, 1459, 1469, 1479, 1489, 1499, 1509, 1519, 1529, 1539, 1549	Room temperature - Measured value 2	RTC x - Input	2 bytes	9,001	C, -, W, T, U

2-byte object for coupling an external KNX temperature sensor (e.g. push-button sensor with temperature measurement) for room temperature detection. The possible temperature range is specified by the KNX DPT 9.001.

The temperature value must always be specified in the format "°C".

## 10.6 Controller status

### Heating/cooling message

Depending on the set operating mode, separate objects can be used to indicate whether the controller is currently demanding heating or cooling energy and is thus actively heating or cooling. As long as the heating command value is > "0", a "1" tele-



gram will be transmitted via the object "Heating status object". The signal telegram is only reset when the command value is "0" ("0" telegram is transmitted). The same applies to the object "Cooling status object".

The signal objects can be enabled by the "Heating status object" or "Cooling status object" parameters in the parameter branch "Room temperature controller x -> RTCx - General -> Status". The control algorithm controls the signal objects. Please note that the command values are recalculated every 30 s, thus updating the signal objects.

### Controller status

The room temperature controller can transmit its current status to the KNX. A choice of data formats is available for this. The parameter "Status" in the parameter node "RTCx - General -> Enabled functions" enables the parameter page "Status". The different status objects can be activated there individually.

- The KNX-compliant controller status feedback is harmonised on a manufacturer-independent basis.
- The objects "Controller status RHCC - KNX compliant", "Controller status RTC - KNX compliant" and "Controller status RTSM - KNX compliant" display elementary basic functions of the controller.
- These objects are supplemented by the two 1-byte objects "Operating mode status" and "Forced operating mode status" (DPT 20.102), which report back the operating mode actually set at the controller. The last two objects mentioned above are generally used to enable controller extensions to display the controller operating mode correctly in the KNX compliant status display. Therefore, these objects should be connected with controller extensions if the KNX-compliant status feedback is not configured.

Bit coding of the 2-byte object "Controller status RHCC - KNX compliant" (DPT 22.101)

Bit of the status telegram	Meaning on "1"	Meaning on "0"
0	Error	No error
1	not used (permanent "0")	
2	not used (permanent "0")	
3	not used (permanent "0")	
4	not used (permanent "0")	
5	not used (permanent "0")	
6	not used (permanent "0")	
7	not used (permanent "0")	
8	"Heating" operating mode	"Cooling" operating mode
9	not used (permanent "0")	
10	not used (permanent "0")	
11	not used (permanent "0")	

Bit of the status telegram	Meaning on "1"	Meaning on "0"
12	Controller disabled (dew point operation)	Controller enabled
13	Frost alarm (frost protection temperature undershot)	No frost alarm (frost protection temperature exceeded)
14	Heat alarm (heat protection temperature exceeded)	No heat alarm (heat protection temperature undershot)
15	not used (permanent "0")	

Bit coding of the 2-byte object "Controller status RTC - KNX compliant" (DPT 22.103)

Bit of the status telegram	Meaning on "1"	Meaning on "0"
0	Error	No error
1	"Heating" operating mode	"Cooling" operating mode
2	Controller disabled (dew point operation)	Controller enabled
3	Frost alarm (frost protection temperature undershot)	No frost alarm (frost protection temperature exceeded)
4	Heat alarm (heat protection temperature exceeded)	No heat alarm (heat protection temperature undershot)
5	Controller inactive (deadband)	Controller active
6	not used (permanent "0")	
7	"Heating" operating mode enabled	"Heating" operating mode disabled
8	"Cooling" operating mode enabled	"Cooling" operating mode disabled
9	not used (permanent "0")	
10	not used (permanent "0")	
11	not used (permanent "0")	
12	not used (permanent "0")	
13	not used (permanent "0")	
14	not used (permanent "0")	
15	not used (permanent "0")	

Bit coding of the 1-byte object "Controller status RTSM - KNX compliant" (DPT 21.107)

Bit of the status telegram	Meaning on "1"	Meaning on "0"
0	Window opened (For "Frost/heat protection = Automatic frost protection":	No window opened (For "Frost/heat protection = Automatic frost protection":

Bit of the status telegram	Meaning on "1"	Meaning on "0"
	<ul style="list-style-type: none"> <li>The bit is active if the automatic frost protection of the temperature drop detection is active.</li> </ul> For "Frost/heat protection = via window status": <ul style="list-style-type: none"> <li>The bit is active if at least one window is open after the delay time has elapsed.)</li> </ul>	<ul style="list-style-type: none"> <li>The bit is inactive if the automatic frost protection of the temperature drop detection is inactive.</li> </ul> For "Frost/heat protection = via window status": <ul style="list-style-type: none"> <li>The bit is inactive if all windows are closed.)</li> </ul>
1	Presence (Presence detector)	No presence (Presence detector)
2	Presence (Presence button)	No presence (Presence button)
3	Comfort extension active	Comfort extension inactive
4	Forced operating mode active	Forced operating mode inactive
5	not used (permanent "0")	
6	not used (permanent "0")	
7	not used (permanent "0")	

- i** Bit 0 of the 1-byte object "Controller status RTSM - KNX compliant" (DPT 21.107) becomes active, depending on the setting of the parameter "Frost/heat protection".

### 10.6.1 Status output parameters

#### Heating / Cooling (depending on the operating mode of the controller)

Status object - Heating	Checkbox (yes / no)
Depending on the set operating mode, a separate object can be used to signal whether the controller is currently demanding heating energy and is thus actively heating. The "Yes" setting here enables the message function for heating.	

Status object - Cooling	Checkbox (yes / no)
Depending on the set operating mode, a separate object can be used to signal whether the controller is currently demanding cooling energy and is thus actively cooling. The "Yes" setting here enables the message function for cooling.	

#### Controller status

Status objects - Operating mode	Checkbox (yes / no)
The room temperature controller can transmit its current status to the KNX. If the parameter is activated, the objects "Operating mode - Preset - Status", "Operating mode - Active mode - Status" and "Operating mode - Forced - Status" are visible.	

Status object - RHCC	Checkbox (yes / no)
The room temperature controller can transmit its current status to the KNX. If the parameter is activated, the object "Controller status RHCC" is visible.	
Status object - RTC	Checkbox (yes / no)
The room temperature controller can transmit its current status to the KNX. If the parameter is activated, the object "Controller status RTC" is visible.	
Status object - RTSM	Checkbox (yes / no)
The room temperature controller can transmit its current status to the KNX. If the parameter is activated, the object "Controller status RTSM" is visible.	

### 10.6.2 Objects for controller status

Object no.	Function	Name	Type	DPT	Flag
339, 389, 439, 489, 539, 589, 639, 689, 739, 789, 839, 889	Operating mode - Preset - Status	Controller x - Output	1 bytes	20,102	C, -, -, T, -
<p>1-byte object used by the controller to output the current operating mode. This object is generally used to enable controller extensions to display the controller operating mode correctly in the KNX compliant status display. Therefore this object should be connected with controller extensions if the KNX compliant status feedback is not configured.</p> <p>After voltage return or an ETS programming operation, the current status is transmitted via this object. This object is only available if the parameter "Status objects - Operating mode" is activated.</p>					
Object no.	Function	Name	Type	DPT	Flag
644	Operating mode - Active mode - Status	Controller x - Output	1 bytes	20,102	C, -, -, T, -
<p>1-byte object used by the controller to output the current operating mode, taking the forced position, presence status and window status into account. This object is only available if the parameter "Status objects - Operating mode" is activated.</p>					

Object no.	Function	Name	Type	DPT	Flag
348, 398, 449, 498, 548, 598, 648, 698, 748, 798, 848, 898	Operating mode - Forced - Status	Controller x - Output	1 bytes	20,102	C, -, -, T, -

1-byte object used by the controller to output the operating mode in the event of forced position. This object is generally used to enable controller extensions to display the controller operating mode correctly in the KNX compliant status display. Therefore this object should be connected with controller extensions if the KNX compliant status feedback is not configured.

After voltage return or an ETS programming operation, the current status is transmitted via this object. This object is only available if the parameter "Status objects - Operating mode" is activated.

Object no.	Function	Name	Type	DPT	Flag
347, 397, 447, 497, 547, 597, 647, 697, 747, 797, 847, 897	Controller status RHCC - KNX-compliant	RTC x - Output	2 bytes	22,101	C, R, -, T, A

2-byte object that the controller uses to display elementary basic functions in a KNX-harmonised manner (RHCC).

After voltage return or an ETS programming operation, the current status is transmitted via this object.

Object no.	Function	Name	Type	DPT	Flag
379, 429, 479, 529, 579, 629, 679, 729, 779, 829, 879, 929	Controller status RTSM - KNX-compliant	RTC x - Output	1 bytes	21,107	C, R, -, T, A

2-byte object that the controller uses to display elementary basic functions in a KNX-harmonised manner (RTSM).

After voltage return or an ETS programming operation, the current status is transmitted via this object.

Object no.	Function	Name	Type	DPT	Flag
965, 1007, 1049, 1091, 1133, 1175, 1217, 1259, 1301, 1343, 1385, 1427	Controller status RTC - KNX-compliant	RTC x - Output	2 bytes	22,103	C, R, -, T, A
2-byte object that the controller uses to display elementary basic functions in a KNX-harmonised manner (RTC). After voltage return or an ETS programming operation, the current status is transmitted via this object.					

Object no.	Function	Name	Type	DPT	Flag
949, 991, 1033, 1075, 1117, 1159, 1201, 1243, 1285, 1327, 1369, 1411	Heating - Status	RTC x - Output	1-bit	1,001	C, R, -, T, A
1-bit object for the controller to report a request for heating energy. Object value = "1": energy request, object value = "0": no energy request.					

Object no.	Function	Name	Type	DPT	Flag
950, 992, 1034, 1076, 1118, 1160, 1202, 1244, 1286, 1328, 1370, 1412	Cooling - Status	RTC x - Output	1-bit	1,001	C, R, -, T, A
1-bit object for the controller to report a request for cooling energy. Object value = "1": energy request, object value = "0": no energy request.					

## 10.7 Boost function

The boost function can be used temporarily to heat or cool a room intensively. If the boost function is activated via the "Boost - Activate / Deactivate" object, the command value is set to maximum (ON or 100%) in the standard parameterisation for a duration of 5 minutes. After the time has elapsed, the boost switches off again automatically.

Once the boost function has elapsed, the controller checks the current actual temperature and the setpoint temperature. The command values set to maximum by the boost function are not switched off until the corresponding temperature limits are exceeded in heating mode and undershot in cooling mode.

The parameter "Boost function" in the parameter node "RTCx - General -> Enabled functions" enables the parameter page "Boost function". The remaining parameters can be set there.

The current status of the boost function and the residual time of a current boost can be sent to the bus.

- i** The boost function cannot be retriggered.
- i** The boost function can be aborted at any time.
- i** The controller calculates the command values cyclically every 30 seconds. This can delay the adoption of the command value by a maximum of 30 s. As this delay affects switching on and off, the duration of the boost function remains unchanged.

### 10.7.1 Boost function parameters

Effect on	<b>Heating</b> Cooling Heating and cooling
The boost function can optionally be used for heating only, for cooling only or for both heating and cooling. The options available for this parameter depend on the operating mode set on the parameter page "RTC x - General".	
In heating mode, effect on	<b>Basic level heating</b> Additional level heating Basic and additional level heating
In the case of heating with the basic and additional levels, the boost function can optionally have an effect on the basic level only, the additional level only or both the basic and additional levels.	
In cooling mode, effect on	<b>Basic level cooling</b> Additional level cooling Basic and additional level cooling
In the case of cooling with the basic and additional levels, the boost function can optionally have an effect on the basic level only, the additional level only or both the basic and additional levels.	

#### Heating

Boost period	1 ... <b>5</b> ... 60 min
The device performs the boost according to the configuration of this parameter for a period of 1 to 60 minutes.	
Boost command value	0 ... <b>100 %</b>
For the configured duration, the command value is set to the value parameterised here, e.g. maximum (ON or 100%).	

#### Cooling



Boost period	1 ... 5 ... 60 min
The device performs the boost according to the configuration of this parameter for a period of 1 to 60 minutes.	
Boost command value	0 ... 100 %
For the configured duration, the command value is set to the value parameterised here, e.g. maximum (ON or 100%).	

Transmission behaviour

Cyclical transmission of residual time (0 = inactive)	0...59 min 0 ... 10...59 s
If the boost function is activated, the object "Boost - Remaining run time" can cyclically transmit the residual time of the running boost function in seconds.	

### 10.7.2 Objects for boost function

Object no.	Function	Name	Type	DPT	Flag
962, 1004, 1046, 1088, 1130, 1172, 1214, 1256, 1298, 1340, 1382, 1424	Boost - Activate / Deactivate	RTC x - Input	1-bit	1,010	C, -, W, -, -
1-bit input object for requirement-orientated activation and deactivation of the boost function. The telegram polarity is fixed: "0" = boost inactive, "1" = boost active. Updates of the object from "1" to "1" or "0" to "0" do not produce a reaction.					
Object no.	Function	Name	Type	DPT	Flag
963, 1005, 1047, 1089, 1131, 1173, 1215, 1257, 1299, 1341, 1383, 1425	Boost function - Status	RTC x - Output	1-bit	1,011	C, R, -, T, -
1-bit object via which the controller outputs the current status of the boost function. When the boost function is activated, the status object is set to the value "1". When the boost function is deactivated, the status object is set to the value "0". After a reset, the status message object value is "0". The status object is only sent when there is a change.					

Object no.	Function	Name	Type	DPT	Flag
964, 1006, 1048, 1090, 1132, 1174, 1216, 1258, 1300, 1342, 1384, 1426	Boost function - Remaining run time	RTC x - Output	2 bytes	7,005	C, R, -, T, -
2-byte object via which the controller outputs the period of the boost function. The residual time of the boost function is transmitted via the object in 10 second increments.					

## 10.8 Floor temperature monitoring

The cyclical monitoring of the floor temperature can be activated in the controller in order to influence the minimum or maximum temperature of a floor heating system. If the monitoring is enabled in the ETS, the controller continuously monitors the floor temperature. If the floor temperature exceeds a specified limiting value during heating or falls below a specified limiting value during cooling, the controller switches off the corresponding command value for heating or cooling. This switches off the heating or cooling and the system cools down or heats up. The controller will only set the most recently calculated command value again when the temperature exceeds / falls below the limiting value minus a hysteresis of 1 K.

- i** With a pulse width-modulated command value, the temperature limit only switches off the command value when the current PWM time cycle has elapsed.
- i** Depending on the configuration, the temperature may have a strong impact on the controller behaviour. Poor parameterisation of the limit temperature (limit temperature near to the room/setpoint temperature) means that it is possible that the specified setpoint temperature for the room can never be reached!
- i** The cyclical monitoring of the floor temperature is used to increase the comfort behaviour of the heating/cooling system and must not be used as a safety-relevant protection function (immediate forced switch-off of the heating/cooling performance).

Which operating mode the cyclical monitoring should be applied to can be set in the ETS. It is possible to limit the minimum and / or the maximum floor temperature by the parameter "Monitoring of". In two-level heating or cooling mode, it is also possible to set whether the floor temperature limit applies to the basic level only, the additional level only or both the basic and additional levels.

The underfloor heating temperature to be monitored is fed into the controller via the KNX communication object "Floor temperature - Measured value". This object can be used to inform the controller of the current floor temperature using suitable temperature value telegrams from other bus devices (e.g. analogue input with temperature sensor, etc.).

The minimum and maximum limit temperatures the underfloor heating system is permitted to reach are specified in the ETS via the parameters "Maximum permissible floor temperature" and "Minimum permissible floor temperature". The temperatures can be set to a value between 10 ... 45 °C. If the limit temperature is exceeded in heating mode or fallen below in cooling mode, the controller switches the floor heating system off via the command value. As soon as the floor temperature has fallen 1 K below the limit temperature in heating mode or risen 1 K above the limit temperature in cooling mode, the controller switches the command value on again, assuming this is provided for in the control algorithm. The hysteresis 1 K is fixed.

- i** The cyclical monitoring does not affect the "Heating" or "Cooling" message telegrams. If the floor temperature exceeds or falls below the limiting value, only the command value is switched off. In this case, the "Heating" or "Cooling" message remains active.
- i** Depending on the configuration, the temperature limiting can have a strong impact on the controller behaviour. Poor parameterisation of the limit temperature (limit temperature near to the room/setpoint temperature) means that it is possible that the specified setpoint temperature for the room can never be reached.
- i** The limiting temperatures for minimum and maximum are not checked for plausibility. The following generally applies: "Minimum permissible floor temperature" < allowed floor temperature range < "Maximum permissible floor temperature".

### 10.8.1 Floor temperature monitoring parameters

Monitoring of	<b>Maximum floor temperature</b> Minimum floor temperature Maximum and minimum floor temperature
This parameter determines which operating mode the cyclical floor temperature monitoring should be applied to. The monitoring can be limited to heating (maximum floor temperature), cooling (minimum floor temperature), or heating and cooling.	
Effect on	Basic level Additional level <b>Basic and additional level</b>
Depending on which heating or cooling circuit is used for the floor, this parameter defines which level is affected by the floor temperature monitoring.	

Heating

Maximum permissible floor temperature	10 ... 35 ... 45 °C
<p>The maximum limit temperature which the floor may reach in heating mode is specified here. If this temperature is exceeded, the controller switches the underfloor heating system off using the command value. As soon as the floor temperature has fallen 1 K under the limit temperature, the controller switches the command value on again, assuming that this is provided for in the control algorithm.</p>	

Cooling

Minimum permissible floor temperature	10 ... 45 °C
<p>The minimum limit temperature which the floor may reach in cooling mode is specified here. If the temperature falls below this value, the controller switches the underfloor cooling system off using the command value. As soon as the floor temperature has risen 1 K above the limit temperature, the controller switches the command value on again, assuming that this is provided for in the control algorithm.</p>	

**10.8.2 Objects for floor temperature monitoring**

Object no.	Function	Name	Type	DPT	Flag
944, 986, 1028, 1070, 1112, 1154, 1196, 1238, 1280, 1322, 1364, 1406	Floor temperature - Limiting value exceeded/undershot - Status	RTC x - Output	1-bit	1,011	C, R, -, T, A
<p>1-bit object for the status output of the monitoring of the configured limiting values of the floor temperature. If the monitoring is enabled in the ETS, the controller continuously monitors the floor temperature. If the floor temperature exceeds a specified limiting value during heating or falls below a specified limiting value during cooling, the controller switches off the corresponding command value for heating or cooling. This switches off the heating or cooling. The controller will only set the most recently calculated command value again when the temperature exceeds / falls below the limiting value minus a hysteresis of 1 K again.</p>					

Object no.	Function	Name	Type	DPT	Flag
945, 987, 1029, 1071, 1113, 1155, 1197, 1239, 1281, 1323, 1365, 1407	Floor temperature - Measured value	RTC x - Input	2 bytes	9,001	C, -, W, -, U
<p>2-byte object for coupling an external temperature sensor for floor temperature monitoring.</p> <p>The temperature value must always be specified in the format "°C".</p>					

## 10.9 Setpoint temperature limit, cooling

In accordance with statutory requirements in Germany and elsewhere, the temperature at the workplace should be a maximum of 26 °C, or at least 6 K below outdoor temperatures higher than 32 °C. Exceeding these limits is only permissible in exceptional circumstances. To meet these requirements, the room temperature controller offers a setpoint temperature limit, which is only effective in cooling mode. If necessary, the controller limits the setpoint temperature to specific values and prevents an adjustment beyond the limits.

The parameter "Limitation type" in the parameter node "Room temperature controller -> RTC xx - General -> Setpoint temperature limit, cooling" can activate the limit and specify its function. The following settings are possible:

- Setting "Only difference to outdoor temperature"

In this setting, the outdoor temperature is monitored and compared to the active setpoint temperature. The desired maximum temperature difference to the outdoor temperature can be specified in the range between 1 K and 15 K. The specification is made using the parameter "Difference between setpoint temperature and outdoor temperature of". The value can be set in step widths of 1 K.

If the outdoor temperature rises above the value of the parameter "Limit above outdoor temperature of", then the controller activates the setpoint temperature limit. It then permanently monitors the outdoor temperature and raises the setpoint temperature so that it is beneath the outdoor temperature by the amount configured. Should the outdoor temperature continue to rise, the controller raises the setpoint temperature until the required difference to the outdoor temperature is achieved. It is then not possible to undershoot the raised setpoint, e.g. by changing the basic setpoint change.

The change to the setpoint temperature limit is temporary. It only applies for as long as the outdoor temperature exceeds the value of the parameter "Limit above outdoor temperature of".

With the setpoint temperature limit, the configured temperature difference relates to the setpoint temperature of the Comfort mode for cooling. In other operating modes, the temperature distance to Comfort mode must be taken into account.

Example:

In the ETS, the difference between the setpoint temperature and the outdoor temperature is set to 6 K. The standby setpoint temperature is configured to 2 K higher than the comfort setpoint temperature. The result of this is that, for command value limiting, the setpoint temperature in Standby mode may only be a maximum of 4 K below the outdoor temperature. The setpoint temperature limit applies to Night mode in the same way.



The automatic raising of the setpoint temperature by the setpoint temperature limit goes only as far as the configured heat protection temperature. Therefore the heat protection temperature can never be exceeded.

- i** A basic setpoint shift never affects an active setpoint temperature limit with differential measurement to the outdoor temperature. In this case, the setpoint temperature limit only works with the unshifted basic setpoint. A setpoint shift active before the limitation is restored after the limitation, if it was not reset in another way, e.g. by an operating mode switchover.
- i** If the setpoint temperature limit is active, the difference between the basic cooling and additional cooling levels is not taken into account. The command values for both levels are identical. Only when the temperature falls below the limit temperature is the difference between the levels considered again.
  - Setting "only maximum setpoint temperature"  
 In this setting, no setpoint temperatures that are greater than the maximum setpoint temperature configured in the ETS are permitted in cooling mode for the Comfort, Standby and Night modes. The maximum setpoint temperature is specified in the parameter "Maximum setpoint temperature in cooling mode" and can be configured within the limits 20 °C to 35 °C in steps of 1 °C. With an active limit, no larger setpoint can be set in cooling operation, e.g. by a basic setpoint change or a setpoint shift. However, heat protection is not influenced by the setpoint temperature limit. The maximum setpoint temperature configured in the ETS generally relates to the comfort setpoint temperature of cooling mode. In other operating modes, the temperature distance to Comfort mode must be taken into account. Example...  
 The maximum setpoint temperature is configured to 26 °C. The standby setpoint temperature is configured to 2 K higher than the comfort setpoint temperature. The result of this is that, for command value limiting, the setpoint temperature in Standby mode is limited to 28 °C. The setpoint temperature limit applies to Night mode in the same way.
  - Setting "Maximum setpoint temperature and difference to outdoor temperature"  
 This setting is a combination of the two above-mentioned settings. In the downward direction, the setpoint temperature is limited by the maximum outdoor temperature difference, whilst in the upward direction, the limit is made by the maximum setpoint.  
 The maximum setpoint temperature has priority over the outdoor temperature difference. This means that the controller keeps on raising the setpoint temperature according to the difference to the outdoor temperature configured in the ETS until the maximum setpoint temperature or the heat protection temperature is exceeded. Then the setpoint is limited to the maximum value.

A setpoint limit enabled in the ETS can be activated or deactivated as necessary using a 1-bit object. For this, the parameter "Activation" can be set to "via object". In this case, the controller only takes the setpoint limit into account if it has been enabled via the object "Setpoint temperature limit - Activate / Deactivate" ("1" telegram). If the limitation is not enabled ("0" telegram), the cooling setpoint temperatures are not limited. After a device reset (bus voltage return, ETS programming operation), the object value is "0", meaning that the setpoint limit is inactive.

- i** The setpoint limit has no function in Heating mode.



### Status message of the setpoint temperature limit

If a setpoint temperature limit is active, this is signalled to the bus via the object "Setpoint temperature limit - Status". This makes it possible for the user to recognise a changed temperature setpoint. After a reset, the status message object value is "0". This corresponds to the normal setpoint of the operating modes "Comfort", "Standby" and "Night". The setpoint temperature status is only sent when there is a change.

#### 10.9.1 Setpoint temperature limit parameters

Limitation type	Only difference to outdoor temperature Only maximum setpoint temperature <b>Maximum setpoint temperature and difference to outdoor temperature</b>
<p>The variable on which the setpoint temperature limit depends can be defined here.</p> <p>"Only difference to outdoor temperature": In this setting, the outdoor temperature is monitored and compared with the active setpoint temperature. The specification of the maximum temperature difference to the outdoor temperature is made using the "Difference to outdoor temperature in cooling mode" parameter. If the outdoor temperature rises above 32 °C, then the controller activates the setpoint temperature limit. It then permanently monitors the outdoor temperature and raises the setpoint temperature so that is beneath the outdoor temperature by the amount configured. Should the outdoor temperature continue rising, the controller raises the setpoint temperature until the required difference to the outdoor temperature is reached, or, at most, the heat protection temperature. It is then not possible to undershoot the raised setpoint, e.g. by changing the basic setpoint change. The change to the setpoint temperature limit is temporary. It only applies for as long as the outdoor temperature exceeds 32 °C.</p> <p>"Only maximum setpoint temperature": In this setting, no setpoint temperatures that are greater than the maximum setpoint configured in the ETS are permitted in cooling mode for the Comfort, Standby and Night modes. The maximum temperature setpoint is specified by the "Max. setpoint temperature in cooling operation" parameter. With an active limit, no larger setpoint can be set in cooling operation, e.g. by a basic setpoint change or a setpoint shift. However, heat protection is not influenced by the setpoint temperature limit.</p> <p>"Maximum setpoint temperature and difference to outdoor temperature": This setting is a combination of the two above-mentioned settings. In the downward direction, the setpoint temperature is limited by the maximum outdoor temperature difference, whilst in the upward direction, the limit is made by the maximum setpoint. The maximum setpoint temperature has priority over the outdoor temperature difference. This means that the controller keeps on raising the setpoint temperature according to the difference to the outdoor temperature configured in the ETS until the maximum setpoint temperature or the heat protection temperature is exceeded. Then the setpoint is limited to the maximum value.</p>	



Limit from an outdoor temperature of	20...32...45 °C
This parameter defines the outdoor temperature at which limitation of the setpoint temperature becomes active in cooling mode.	
Difference between setpoint temperature and outdoor temperature of	1 ...6 ...15 K
This parameter defines the maximum difference between the setpoint temperature in Comfort mode and the outdoor temperature with an active setpoint temperature limit. This parameter is visible only if setpoint temperature monitoring is enabled. However, this is only if the parameter "Setpoint temperature limit in cooling operation" is then set to "Only difference to outdoor temperature" or "Max. setpoint temperature and difference to outdoor temperature".	
Maximum setpoint temperature	20°C...26°C...35°C
This parameter defines the maximum setpoint temperature in Comfort mode with an active setpoint temperature limit. This parameter is visible only if setpoint temperature monitoring is enabled. However, this is only if the parameter "Setpoint temperature limit in cooling operation" is then set to "Only max. setpoint temperature" or "Max. setpoint temperature and difference to outdoor temperature".	
Activation	via object permanently active
A setpoint limit enabled in the ETS can be activated or deactivated as necessary using a 1-bit object. For this, this parameter can be set to "Yes". In this case, the controller only takes the setpoint limit into account, if it has been enabled via the object "Cooling setpoint temperature limit" ("1" telegram). If the limitation is not enabled ("0" telegram), the cooling setpoint temperatures are not limited. This parameter is visible only if setpoint temperature monitoring is enabled.	

### 10.9.2 Objects for setpoint temperature limit

Object no.	Function	Name	Type	DPT	Flag
364, 414, 464, 514, 564, 614, 664, 714, 764, 814, 864, 914	Setpoint temperature limit - Activate / Deactivate	RTC x - Input	1-bit	1,001	C, -, W, -, U
1-bit object for activation or deactivation of a setpoint temperature limit. <ul style="list-style-type: none"> <li>- "0" = deactivate raising of setpoint</li> <li>- "1" = activate raising of setpoint</li> </ul> If the setpoint limit is permanently activated, the communication object is not visible.					

Object no.	Function	Name	Type	DPT	Flag
364, 414, 464, 514, 564, 614, 664, 714, 764, 814, 864, 914	Setpoint temperature limit - Status	RTC x - Output	1-bit	1,011	C, R, -, T, A
1-bit object for signalling an active setpoint temperature limit. <ul style="list-style-type: none"> <li>- "0" = raising of setpoint not active</li> <li>- "1" = raising of setpoint active</li> </ul>					

## 10.10 Setpoint temperature increase, heating

The room temperature controller offers a setpoint temperature increase, which is only effective in heating mode.

The comfort and standby setpoints are raised gradually as the outdoor temperature falls. This counteracts the radiative cooling from outdoor walls in winter, increasing the sense of well-being. The working range can be configured and is defined via the parameter "Raise from difference between setpoint temperature and outdoor temperature of".

The following values are used for calculation of the setpoint temperature increase:

- Setpoint temperature (before increase)
- Current outdoor temperature
- Configured difference between setpoint temperature and outdoor temperature
- Increase factor

These values are used in the following formula:

Setpoint temperature increase = Setpoint temperature + (Setpoint temperature - (Outdoor temperature + Difference between setpoint temperature and outdoor temperature)) x Increase factor

Example for setpoint temperature increase:

- Heating Comfort mode setpoint temperature = Specified setpoint temperature = 21 °C
- Difference between setpoint temperature and outdoor temperature = 10 K
- Increase factor = 10

Outdoor temperature = 11 °C, Preset setpoint + (Preset setpoint (Outdoor temperature + Difference between setpoint temperature and outdoor temperature) x Factor) = 21.0 °C

-> Set setpoint temperature = Specified setpoint temperature = 21 °C

Outdoor temperature = 10 °C, Preset setpoint + (Preset setpoint (Outdoor temperature + Difference between setpoint temperature and outdoor temperature) x Factor) = 21.1 °C

-> Set setpoint temperature = Calculated setpoint temperature = 21.1 °C

<p>Example for setpoint temperature increase:</p> <ul style="list-style-type: none"> <li>- Heating Comfort mode setpoint temperature = Specified setpoint temperature = 21 °C</li> <li>- Difference between setpoint temperature and outdoor temperature = 10 K</li> <li>- Increase factor = 10</li> </ul>
<p>Outdoor temperature = 9 °C, Preset setpoint + (Preset setpoint (Outdoor temperature + Difference between setpoint temperature and outdoor temperature) x Factor) = 21.2 °C</p> <p>-&gt; Set setpoint temperature = Calculated setpoint temperature = 21.2 °C</p>
<p>Outdoor temperature = 8 °C, Preset setpoint + (Preset setpoint (Outdoor temperature + Difference between setpoint temperature and outdoor temperature) x Factor) = 21.3 °C</p> <p>-&gt; Set setpoint temperature = Calculated setpoint temperature = 21.3 °C</p>

If the value of the shifted outdoor temperature (grey characteristic line) falls below the value of the specified setpoint temperature (green characteristic line), the calculated setpoint temperature (blue characteristic line) becomes active. When setpoint temperature increase is activated, the calculated setpoint is then set as the setpoint temperature. Correspondingly, the specified setpoint temperature is reactivated when the calculated setpoint temperature value falls below the specified setpoint temperature.

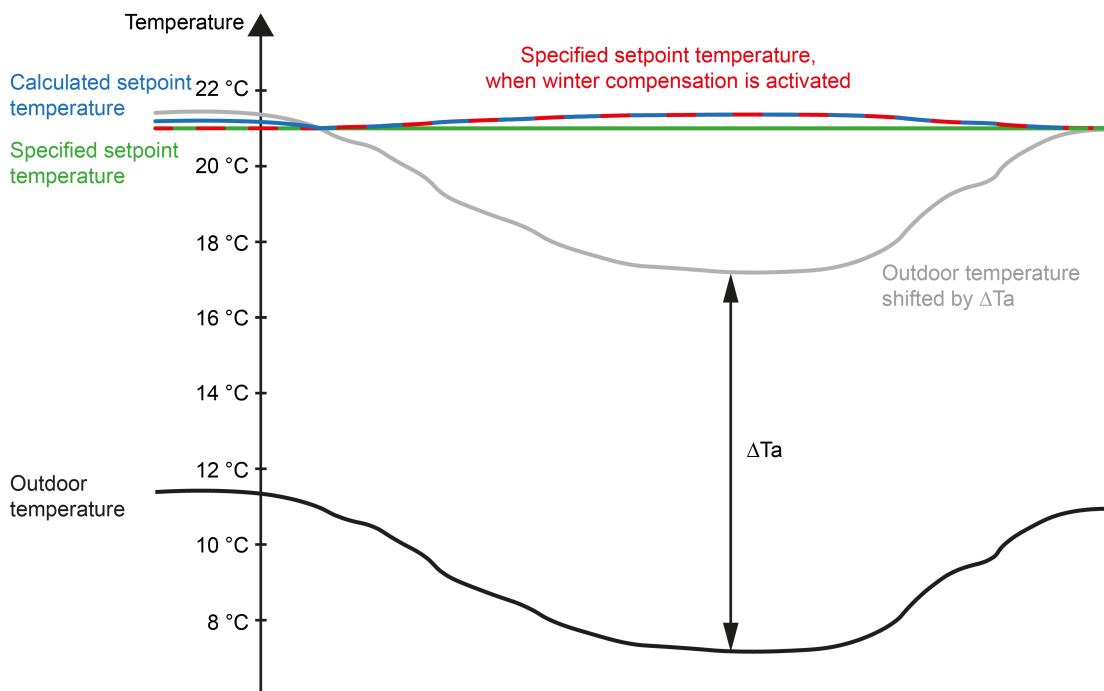

Image 44: Example for winter compensation

$\Delta T_a$  Configured difference between setpoint temperature and outdoor temperature

**Additional information about setpoint temperature increase, heating**

- The precondition for "setpoint temperature increase, heating" is reception of a valid outdoor temperature.

- Setpoints shifted by "setpoint temperature increase, heating" are checked against the frost and heat protection temperatures and if they fall below or exceed them respectively, they are restricted to these values.
- The "setpoint temperature increase, heating" only works in the operating modes Comfort and Standby.
- Switching between heating and cooling changes the operating mode; which is the corresponding precondition for "setpoint temperature increase, heating".
- "Cooling" mode switches "setpoint temperature increase, heating" to inactive and sets its offset to the value "0".
- An operating mode switchover to Comfort or Standby operating mode does not affect the "setpoint temperature increase, heating". By contrast, the Night and Frost/heat protection modes switch the "setpoint temperature increase, heating" to inactive.

### Status message of setpoint temperature increase, heating

If "setpoint temperature increase, heating" is active, this is signalled to the bus via the object "Setpoint temperature increase - Status". This makes it possible for the user to recognise a changed temperature setpoint. After a reset, the status message object value is "0". This corresponds to the normal setpoint of the operating modes "Comfort", "Standby" and "Night". The setpoint temperature status is only sent when there is a change.

#### 10.10.1 Setpoint temperature increase parameters

Increase beyond difference between setpoint temperature and outdoor temperature of	10 ...15 ...20 K
This parameter defines the difference between the setpoint temperature and the outdoor temperature beyond which the setpoint temperature increase gradually takes effect.	
Increase factor	0...0.2
This parameter defines the intensity of the setpoint temperature increase.	

### 10.10.2 Objects for setpoint temperature increase

Object no.	Function	Name	Type	DPT	Flag
363, 413, 463, 513, 563, 613, 663, 713, 763, 813, 863, 913	Setpoint temperature increase - Status	RTC x - Output	1-bit	1,011	C, R, -, T, A
1-bit object for signalling an active setpoint temperature increase. <ul style="list-style-type: none"> <li>- "0" = raising of setpoint not active</li> <li>- "1" = raising of setpoint active</li> </ul>					

## 10.11 Scenes

Up to 64 scenes can be created for the room temperature controller and scene values (operating mode) stored. The scene values are recalled or stored via a separate scene extension object. The data point type of the extension object permits addressing of all scenes.

The scene function must be enabled on the parameter page "Room temperature controller -> RTCx - General -> Enabled functions" so that the required communication objects and parameters (on the parameter page "Room temperature controller -> RTCx - General -> Scenes") become visible.

The scene configuration selected in the parameterization decides whether the number of scenes is either variable (1 ... 64) or alternatively fixed to the maximum (64).

- Scene configuration = "variable (1 ... 64 scenes)"  
With this setting, the number of scenes used can be selected anywhere in the range 1 to 64. The parameter "Number of scenes" decides how many scenes are visible in the ETS and can therefore be used. It is possible to specify which scene number (1 ... 64) controls each scene.
- Scene configuration = "fixed (64 scenes)"  
With this setting, all scenes are always visible and can therefore be used. The scenes are controlled via permanently assigned scene numbers (1 ... 64) (scene number 1 -> scene 1, scene number 2 -> scene 2 ...). If necessary, individual scenes can be deactivated.

The scene function can be combined together with other functions of the room temperature controller, whereby the last received or set state is always executed.

#### Presetting a scene recall delay

Each scene recall of the room temperature controller can also be optionally delayed. With this feature, dynamic scene sequences can be configured if several scene outputs are combined with cyclical scene telegrams.

### Precondition

The scene function must be enabled on the parameter page "Room temperature controller -> RTCx - General -> Enabled functions".

- On the parameter page "Room temperature controller -> RTCx - General -> Scenes", activate the parameter "Delay scene recall".

The delay time is now activated and can be configured separately. The delay only affects the scene recall of the room temperature controller. The delay time is started on arrival of a recall telegram. Only after the time has elapsed is the corresponding scene called up and the operating mode set.

- i** Each scene recall telegram restarts the delay time and retriggers it. If a new scene recall telegram is received while a delay is active (scene recall not yet executed), the old (and not yet recalled scene) will be rejected and only the scene last received executed.
- i** The scene recall delay has no influence on the storage of scene values. A scene storage telegram within a scene recall delay terminates the delay and thus the scene recall.

### Presetting the behaviour during ETS programming

When saving a scene, the operating modes are stored internally in the device in a non-volatile manner. To ensure that the stored values are not replaced by the originally programmed scene operating modes during an ETS programming operation of the application program or the parameters, the actuator can prevent the operating modes from being overwritten. As an alternative, the original values can be reloaded into the device during each programming run of the ETS.

### Precondition

The scene function must be enabled on the parameter page "Room temperature controller x -> RTCx - General -> Enabled functions".

- Activate the parameter "Overwrite values stored in the device during the ETS programming operation" on the parameter page "Room temperature controller x -> RTCx - General -> Scenes".

With each ETS programming operation of the application program or the parameters, the scene operating modes configured in the ETS are programmed into the actuator. This may overwrite the scene operating modes stored in the device by means of a storage function.

- Deactivate the parameter "Overwrite values stored in the device during the ETS programming operation".

Scene operating modes that may have been stored in the device by means of a storage function are maintained. If no scene switching states have been stored, the last operating modes programmed in by the ETS remain valid.

- i** When commissioning the actuator for the first time, the parameter should be activated so that the operating mode is initialised to valid scene operating modes.

## Presetting scene numbers and scene operating modes

The presetting of the scene number can be defined for each scene of the room temperature controller, by which scene number (1...64) the scene is addressed, i.e. called up or stored.

The data point type of the scene extension object permits addressing of up to 64 scenes max.

In addition to defining the scene number, it must be defined which scene command (Comfort mode, Standby mode, Night mode, Frost/heat protection) is to be set when a scene is called up on the room temperature controller.

### Precondition

The scene function must be enabled on the parameter page "Room temperature controller x -> RTCx - General -> Enabled functions".

- On the parameter page "Room temperature controller x -> RTCx - General -> Scenes", set the parameter "Scene number" for each scene to the number by which the scenes are to be addressed.

A scene can be addressed with the configured scene number. A setting of "0" deactivates the corresponding scene so that neither recalling nor storage is possible.

- i** If the same scene number is configured for several scenes, only the scene with the lowest sequential number will be addressed. The other scenes will be ignored in this case.

- On the parameter page "Room temperature controller RTC -> RTC - General -> Scenes", set the "Operating mode" parameter for each scene to the desired operating mode.

With a scene recall, the configured operating mode is recalled and set at the room temperature controller.

- i** The configured operating mode is adopted in the actuator during an ETS programming operation only if the parameter "Overwrite values stored in the device during the ETS programming operation" is activated.

## Presetting storage behaviour

The operating mode set on the room temperature controller can be stored internally when a scene storage telegram is received via the extension object. The operating mode can be influenced by all functions of the room temperature controller before storage, provided that the individual functions are also enabled.

### Precondition

The scene function must be enabled on the parameter page "Room temperature controller x -> RTCx - General -> Enabled functions".

- On the parameter page "Room temperature controller x -> RTCx - General -> Scenes", activate the "Storage function" parameter for each scene.



The storage function is activated for the scene in question. When a storage telegram is received via the "Scene extension" object, the current operating mode is stored internally.

- Deactivate the parameter "storage function" for each scene.

The storage function is deactivated for the scene in question. A storage telegram received via the "scene extension" object will be rejected.

### Configuring extended scene recall

The extended scene recall allows calling of up to 64 scenes of a room temperature controller in sequence. Here, scene recall takes place via the 1-bit communication object "Extended scene recall". Each ON telegram received via this object recalls the next of the available scenes in the configuration. Each OFF telegram received recalls the previous scene.

With the extended scene recall, the controller always recalls the neighbouring scene - starting with the scene most recently recalled via the extended recall. It is irrelevant whether the scene is active (scene number = "1...64" or scene active) or inactive (scene number = "0" or scene inactive). If an inactive scene is recalled via the extended scene recall, the room temperature controller will not react.

Only the scenes available in the scene configuration can be selected via the extended scene recall (with "variable" defined by the parameter "number of scenes", with "fixed" always all 64 scenes). After a reset (bus voltage return, ETS programming operation), an ON or OFF telegram always recalls scene 1 first.

**i** Recall of a scene via the 1-byte extension object does not influence the scene sequence of the extended scene recall. The two recall functions work independently of each other.

- On the parameter page "Room temperature controller -> RTCx - General -> Scenes", activate the parameter "Extended scene recall".

The object "Extended scene recall" is available. Each ON telegram recalls the next scene. Each OFF telegram recalls the previous scene.

- Deactivate the parameter "Extended scene recall".

The extended scene recall is deactivated. A scene recall can only take place via the 1-byte scene extension object.

The extended scene recall can take place with or without an overflow at the scene limits. An overflow occurs when the last scene of the selected configuration is reached when counting up or scene 1 when counting down and an additional telegram in the last counting direction is received by the actuator. The overflow behaviour is defined in the ETS.

- Activate the parameter "with overflow".

After reaching the last scene of the selected configuration, a further ON telegram of the overflow is executed and scene 1 is recalled. Similarly, after reaching scene 1, the overflow is executed by further OFF telegram and the last scene of the selected configuration is recalled.

- Deactivate the parameter "With overflow".

A scene overflow is not possible. After reaching the last scene of the selected configuration, further ON telegrams of the extended scene recall are ignored. In the same way, the actuator ignores further OFF telegrams if scene 1 was recalled last.

### 10.11.1 Scene parameters

Room temperature controller RTC -> RTC - General -> Enabled functions

Scenes	Checkbox (yes / no)
This parameter can be used disable or to enable the scene function.	

Room temperature controller RTC -> RTC - General -> Scenes

Delay scene recall	Checkbox (yes / no)
A scene is recalled via the scene extension object. If required, the scene recall can be delayed on reception of a recall telegram (parameter activated). The recall is alternatively made immediately on reception of the telegram (parameter deactivated).	

Delay time minutes (0...59)	0...59
This parameter specifies the length of the scene delay time. Sets the scene delay time in minutes.	

Seconds (0...59)	0...10...59
Sets the scene delay time in seconds. The delay time parameters are only visible, if the parameter "Delay scene recall" is activated.	

Overwrite values stored in the device during the ETS programming operation	Checkbox (yes / no)
During storage of a scene, the scene values are stored internally to memory in the device. To prevent the stored values from being replaced during ETS programming by the originally programmed scene values, the actuator can inhibit overwriting of the scene values (parameter deactivated). As an alternative, the original values can be reloaded into the device during each programming run of the ETS (parameter activated).	

Extended scene recall	Checkbox (yes / no)
The extended scene recall allows calling of up to 64 scenes of a controller in sequence. Here, scene recall takes place via the 1-bit communication object "Extended scene recall". Each ON telegram received via this object recalls the next scene. Each OFF telegram received recalls the previous scene. This parameter enables extended scene recall, if required.	

With overflow	Checkbox (yes / no)
<p>The extended scene recall can take place with or without an overflow at the scene limits. An overflow occurs when the last scene of the selected configuration is reached when counting up or scene 1 when counting down and an additional telegram in the last counting direction is received by the actuator.</p> <p>Parameter activated: After reaching the last scene of the selected configuration, a further ON telegram of the overflow is executed and scene 1 is recalled. Similarly, after reaching scene 1, the overflow is executed by further OFF telegram and the last scene of the selected configuration is recalled.</p> <p>Parameter deactivated: A scene overflow is not possible. After reaching the last scene of the selected configuration, further ON telegrams of the extended scene recall are ignored. In the same way, the actuator ignores further OFF telegrams if scene 1 was recalled last.</p> <p>This parameter is only visible when the extended scene recall is used.</p>	

Scene configuration	<b>variable (1...64 scenes)</b> fixed (64 scenes)
<p>The scene configuration selected here decides whether the number of scenes is either variable (1 ... 64) or alternatively fixed to the maximum (64).</p> <p>variable (1...64 scenes): With this setting, the number of scenes used can be selected anywhere in the range 1 to 64. The parameter "Number of scenes" decides how many scenes are visible for the switching output in the ETS and can therefore be used. It is possible to specify which scene number (1 ... 64) controls each scene.</p> <p>fixed (64 scenes): With this setting, all scenes are always visible and can therefore be used. The scenes are controlled via permanently assigned scene numbers (1 ... 64) (scene number 1 -&gt; scene 1, scene number 2 -&gt; scene 2 ...). If necessary, individual scenes can be deactivated.</p>	

Number of scene assignments	1...10...64
<p>This parameter defines how many scenes are visible for the room temperature controller in the ETS and can therefore be used.</p>	

Scene number	0...1*...64 *: The predefined scene number is dependent on the scene (1...64).
<p>It is possible to preset which scene number (1 ... 64) controls each scene. A setting of "0" deactivates the corresponding scene so that neither recalling nor storage is possible. If the same scene number is configured for several scenes, only the scene with the lowest sequential number will be addressed. The other scenes will be ignored in this case.</p>	

Operating mode	Comfort mode Standby mode Night mode Frost/heat protection mode
----------------	--

This parameter is used for configuring the operating mode which is set when the scene is recalled.

Memory function	Checkbox (yes / no)
If the parameter is activated, the storage function of the scene is enabled. The current operating mode can then be stored internally via the extension object on receipt of a storage telegram. If the parameter is deactivated, the storage telegrams are rejected.	

### 10.11.2 Objects for scenes

Object no.	Function	Name	Type	DPT	Flag
1557, 1560, 1563, 1566, 1569, 1572, 1575, 1578, 1581, 1584, 1587, 1590	Scenes - Extension	RTC x - Input	1 bytes	18,001	C, -, W, -, U
1-byte object for polling or saving a scene.					

Object no.	Function	Name	Type	DPT	Flag
1558, 1561, 1564, 1567, 1570, 1573, 1576, 1579, 1582, 1585, 1588, 1591	Scenes - Extended scene recall	RTC x - Input	1-bit	1,001	C, (R), W, -, A
1-bit object for extended scene recall. Each ON telegram received recalls the next scene of a controller in sequence. Each OFF telegram received recalls the previous scene. After a reset (bus voltage return, ETS programming operation), an ON or OFF telegram always recalls scene 1 first.					

## 11 Logic functions

The device contains up to 8 logic functions. Simple or complex logical operations in a KNX installation can be performed using these functions. Linking of input and output objects allows the networking of logic functions, permitting the execution of complex operations.

### Enabling and configuring the number of logic functions

To be able to use logic functions, they must be enabled centrally on the "General" parameter page.

- Activate the parameter "Logic functions".  
The logic functions can be used. The "Logic functions" parameter node becomes available, which contains additional parameter pages. The configuration of the logic functions takes place in this parameter node.

Logic functions can be enabled in steps so that the number of visible functions and, in consequence, the available parameters and communication objects are visible in the ETS. The number of available logic functions can be defined on the "Logic functions" parameter page.

- Configure the "Number of logic functions" parameter to the desired value.  
As many logic functions are created as have been selected.
- ❗ The application program deletes existing logic functions from the configuration if the number of available functions is reduced.

Up to two time functions can be preset for each switching output, independently of each other. The time functions affect the communication objects "Switching" and delay the object value received depending on the telegram polarity .

- ❗ At the end of a disabling function, the switching state received during the function or set before the function can be tracked. At the same time, residual times of time functions are also tracked if these had not yet fully elapsed at the time of the reactivation.
- ❗ The time delays do not influence the staircase function if this is enabled.
- ❗ A time delay still in progress will be fully aborted by a reset of the actuator (bus voltage failure or ETS programming).

## 11.1 Logic functions parameters

### General

Logic functions	Checkbox (yes / no)
This parameter enables the logic functions globally. If the parameter is activated, the "Logic functions" parameter node becomes available, which contains additional parameter pages. The configuration of the logic functions takes place in this parameter node.	

Number of logic functions (1...8)	1...8
The number of required logic functions is defined here.	

### Logic functions -> Logic function...

Name of logic function	Free text
The text entered in this parameter is applied to the name of the communication objects and is used to label the logic function in the ETS parameter window (e. g. "limit value switch outside temperature", disabling of Venetian blind garden door). The text is not programmed in the device.	

<p>Type of logic function</p>	<p><b>Logic gate</b>                  Converter (1 bit -&gt; 1 byte)                  Disabling element [Filtering/Time]                  Comparator                  Limit value switch with hysteresis</p>
<p>It is possible to be define which logical operation is to be executed for each logic function. This parameter is only visible if the logic functions have been enabled on the "General" parameter page.</p> <p>Logic gate: The logic function works as a Boolean logic gate with optionally 1 ... 4 inputs and one output.</p> <p>Converter (1 bit -&gt; 1 byte): The logic function is configured as a converter. The converter has a 1-bit input and a 1-byte output and also a disabling object. ON / OFF telegrams can be converted to preconfigured values. The disabling object is able to deactivate the converter.</p> <p>Disabling element (Filtering/Time): The logic function is configured as a disabling element. The disabling element has a 1-bit input and a 1-bit output. This logic function can delay input signals depending on the state (ON or OFF) and output them filtered at the output. A disabling object is also available, which can be used to deactivate the disabling element.</p> <p>Comparator: The logic function works as a comparator with an input whose data format can be parameterised, and with a 1-bit output to output the result of the comparison operation. The reference function and the reference value are configured in the ETS.</p> <p>Limit value switch with hysteresis: The logic function acts like a limit switch with hysteresis. An input with a configurable data format and a 1-bit output are available. The hysteresis is determined by an upper and lower threshold. The threshold values can be parameterised in the ETS. The input value is compared with the threshold values. The command at the output (ON / OFF) upon exceeding or falling below the configured threshold values can be configured.</p>	



## 11.2 Logic gate

A logic gate has up to 4 Boolean inputs (1 bit) and one logic output (1 bit). In consequence, a logic operation only supports the 1-bit data format. The following table shows configurable comparison operations Logic gate and explains their function.

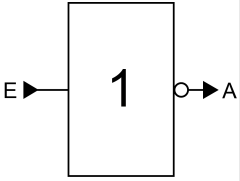
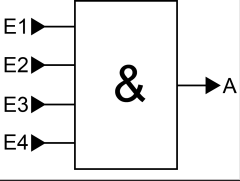
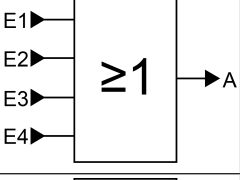
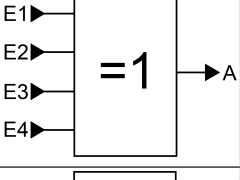
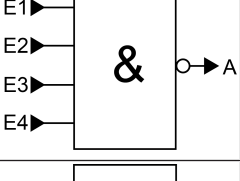
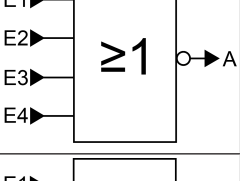
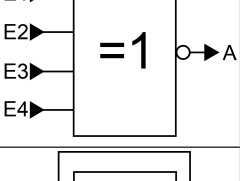
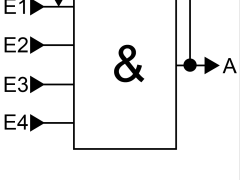
Logic gate	Description	Icon
Invert (NOT)	The logic gate has only one input. The input is forwarded to the gate output inverted.	
AND (AND)	Logic gate has 4 inputs. The output is "1" if all inputs are "1". Otherwise the output is "0".	
OR (OR)	Logic gate has 4 inputs. The output is "0" if all inputs are "0". Otherwise the output is "1".	
Exclusive OR (XOR)	Logic gate has 4 inputs. The output is "1" if only one input is "1". Otherwise the output is "0".	
Inverted AND (NAND)	Logic gate has 4 inputs. The output is "0" if all inputs are "1". Otherwise the output is "1".	
Inverted OR (NOR)	Logic gate has 4 inputs. The output is "1" if all inputs are "0". Otherwise the output is "0".	
Inverted Exclusive OR (NXOR)	Logic gate has 4 inputs. The output is "0" if only one input is "1". Otherwise the output is "1".	
AND with feedback (ANDR)	Logic gate has 4 inputs. The output is fed back to the first input of the gate. The output is "1" if all inputs are "1". Otherwise the output is "0". If input 1 is set to "1" and the output is still "0", the feedback of input 1 is also reset to "0". Only when	

Logic gate	Description	Icon
	<p>inputs 2 ... 4 are "1" will a newly received "1" at input 1 cause the output to assume the logical state "1".</p> <p>Application: Switch light manually only at twilight -&gt; Switch on input 1, twilight sensor on input 2 -&gt; The manual switching signal is ignored for as long as the twilight sensor has not issued an enabling signal. The manual switching sign is only executed at twilight.</p>	

Inputs of a logic gate can be activated or deactivated separately. This allows gates with an individual number of inputs (1 ... 4) to be implemented. As an option, it is possible to invert inputs.

The transmission behaviour of the gate output can be configured.

### 11.2.1 Logic gate parameters

Logic functions -> Logic function...

Selection logic gate	Invert (NOT) <b>AND (AND)</b> OR (OR) Exclusive OR (XOR) Inverted AND (NAND) Inverted OR (NOR) Inverted Exclusive OR (NXOR) AND with feedback (ANDR)
<p>This parameter defines the function of the logic gate and is only visible if "Type of logic function = logic gate".</p> <p><b>Invert (NOT):</b> The inverter is configured. The gate has one input and one output. The Boolean data value of the input is forwarded to the output inverted.</p> <p><b>And (AND):</b> An AND gate is configured. The gate has 1...4 inputs and one output. The inputs are logically AND-linked. The result is forwarded to the output.</p> <p><b>Or (OR):</b> An OR gate is configured. The gate has 1...4 inputs and one output. The inputs are logically OR-linked. The result is forwarded to the output.</p> <p><b>Exclusive-OR (XOR):</b> An exclusive-OR gate is configured. The gate has 1...4 inputs and one output. The inputs are logically Exclusive-OR-linked. The result is forwarded to the output.</p> <p><b>Inverted AND (NAND):</b> An AND gate is configured. The gate has 1...4 inputs and one output. The inputs are logically AND-linked. The result is forwarded to the output inverted.</p> <p><b>Inverted OR (NOR):</b> An OR gate is configured. The gate has 1...4 inputs and one output. The inputs are logically OR-linked. The result is forwarded to the output inverted.</p> <p><b>Inverted Exclusive OR (NXOR):</b> An inverted Exclusive OR gate is configured. The gate has 1...4 inputs and one output. The inputs are logically Exclusive-OR-linked. The result is forwarded to the output inverted.</p> <p><b>AND with feedback (ANDR):</b> An AND gate with feedback is configured. The gate has 1...4 inputs and one output. The output is fed back to the first input of the gate.</p>	
Input 1	deactivated <b>Input object</b>
<p>Inputs of a logic gate can be activated or deactivated separately. This allows gates with an individual number of inputs (1 ... 4) to be implemented. This parameter defines whether the first input of the gate should be used.</p> <p>This parameter is only visible if "Type of logic function = logic gate".</p>	

Input 2	deactivated Input object
<p>Inputs of a logic gate can be activated or deactivated separately. This allows gates with an individual number of inputs (1 ... 4) to be implemented. This parameter defines whether the second input of the gate should be used.</p> <p>This parameter is only visible if "Type of logic function = logic gate".</p>	
Input 3	deactivated Input object
<p>Inputs of a logic gate can be activated or deactivated separately. This allows gates with an individual number of inputs (1 ... 4) to be implemented. This parameter defines whether the third input of the gate should be used.</p> <p>This parameter is only visible if "Type of logic function = logic gate".</p>	
Input 4	deactivated Input object
<p>Inputs of a logic gate can be activated or deactivated separately. This allows gates with an individual number of inputs (1 ... 4) to be implemented. This parameter defines whether the fourth input of the gate should be used.</p> <p>This parameter is only visible if "Type of logic function = logic gate".</p>	
Invert input	Checkbox (yes / no)
<p>It is possible to invert inputs of the logic gate as an option. This parameter is available for each input of the gate and defines whether the respective input should be evaluated unchanged or inverted.</p> <p>This parameter is only visible if "Type of logic function = logic gate".</p>	
Transmission criteria	always transmit when the input is updated transmit only if the output changes transmit cyclically
<p>The transmission behaviour of the output can be configured here.</p> <p>Always transmit when the input is updated: The output transmits the current object value to the KNX with every telegram that is received at the input.</p> <p>Transmit only if the output changes: The output only transmits the current object value if the object value has changed compared to the last transmission process. During the first telegram to an input after bus voltage return or after an ETS programming operation, the output always transmits to an input.</p> <p>Transmit cyclically: With this setting, the output transmits the current object value to the KNX cyclically. After bus voltage return or after an ETS programming operation, the cyclical transmission is only started once the first telegram has been received at the input. The output also transmits as soon as a new telegram is received at the input. At the same time, the cycle time for cyclical transmission is restarted!</p>	

Transmission delay for sending the hours result (0...99)	0...99
<p>An optional delay before result transmission (telegram at output) can be configured.</p> <p>With the setting "always transmit when the input is updated": Telegrams at the output are only transmitted after the trigger when the delay has elapsed. The delay time is restarted by each telegram at the input.</p> <p>With the setting "only transmit if the output changes": Telegrams are only sent when the object value changes at the output if the delay has expired. If the logic function is reprocessed by a new telegram at the input within the delay time and the object value changes again, then the delay restarts. If the object value of the output does not change due to new input telegrams, the delay does not restart.</p> <p>This parameter defines the hours of the delay time.</p>	
Minutes (0...59)	0...59
<p>This parameter defines the minutes of the delay time.</p>	
Seconds (0...59)	0...59
<p>This parameter defines the seconds of the delay time.</p> <p>The parameters for the transmission delay are only visible for "Transmission criteria" = "Always transmit when the input is updated" and "Only transmit when the output changes".</p>	
Cycle time hours (0...99)	0...99
<p>During cyclical transmission of the output, this parameter defines the cycle time.</p> <p>Setting the cycle time hours.</p>	
Minutes (0...59)	0...5...59
<p>This parameter defines the minutes of the cycle time.</p>	
Seconds (0...59)	0...59
<p>This parameter defines the seconds of the cycle time.</p> <p>The parameters for the cycle time are only visible if "transmission criteria" = "transmit cyclically".</p>	

### 11.2.2 Logic gate object list

Object no.	Function	Name	Type	DPT	Flag
970, 974, 978, 982, 986, 990, 994, 998	Logic gate... Input 1	Logic... - Input	1-bit	1,002	C, (R), W, -, A
<p>1-bit object as input 1 of a logic gate (1...8). The input status can be inverted optionally.</p> <p>This object is only available if the type of logic function is configured to "logic gate" and input 1 is used.</p>					

Object no.	Function	Name	Type	DPT	Flag
971, 975, 979, 983, 987, 991, 995, 999	Logic gate... Input 2	Logic... - Input	1-bit	1,002	C, (R), W, -, A
<p>1-bit object as input 2 of a logic gate (1...8). The input status can be inverted optionally.</p> <p>This object is only available if the type of logic function is configured to "logic gate" and input 2 is used.</p>					

Object no.	Function	Name	Type	DPT	Flag
972, 976, 980, 984, 988, 992, 996, 1000	Logic gate... Input 3	Logic... - Input	1-bit	1,002	C, (R), W, -, A
<p>1-bit object as input 3 of a logic gate (1...8). The input status can be inverted optionally.</p> <p>This object is only available if the type of logic function is configured to "logic gate" and input 3 is used.</p>					

Object no.	Function	Name	Type	DPT	Flag
973, 977, 981, 985, 989, 993, 997, 1001	Logic gate... Input 4	Logic... - Input	1-bit	1,002	C, (R), W, -, A
<p>1-bit object as input 4 of a logic gate (1...8). The input status can be inverted optionally.</p> <p>This object is only available if the type of logic function is configured to "logic gate" and input 4 is used.</p>					

Object no.	Function	Name	Type	DPT	Flag
1058, 1060, 1062, 1064, 1066, 1068, 1070, 1072	Logic gate output	Logic... - Output	1-bit	1,002	C, (R), -, T, A
<p>1-bit object as output of a logic gate (1...8).</p> <p>This object is only available if the type of logic function is configured to "logic gate".</p>					



### 11.3 Converter (1 bit -> 1 byte)

The converter has a 1-bit input and a 1-byte output and also a disabling object. ON / OFF telegrams can be converted to preconfigured values. The disabling object is able to deactivate the converter.

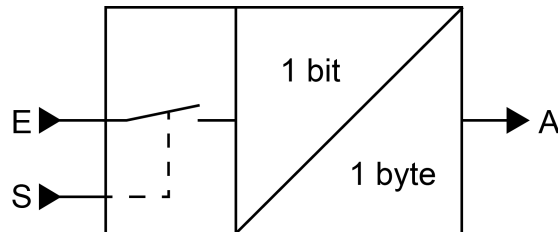

Image 45: Converter (1 bit -> 1 byte)

The converter can react differently to input states. The parameter "Reaction at input to" defines whether the converter responds to ON and OFF commands or alternatively only processes ON or OFF telegrams.

A concrete 1-byte output value can be assigned to each 1-bit input status. The two output values can be configured anywhere in the range 0 ... 255 as required. The data format of the converter output object is set to DPT 5.001 (0...100%).

The disabling object can be deactivated via the converter. A deactivated converter no longer processes input states and consequently does not convert any new output values (the last value is retained and transmitted cyclically, if necessary). At the end of a disabling function, the converter is enabled again. The converter then waits for the next telegram at the input.

The telegram polarity of the disabling object can be configured.

The transmission behaviour of the converter output can be configured.

### 11.3.1 Converter parameters

Logic functions -> Logic function...

Reaction at input to	<b>ON and OFF telegrams</b> ON telegrams OFF telegrams
The converter can react differently to input states. It is defined here whether the converter responds to ON and OFF commands or alternatively only processes ON or OFF telegrams.	
Polarity of the disabling object	<b>0 = enabled / 1 = disabled</b> 0 =disabled/ 1 = enabled
This parameter defines the polarity of the disabling object.	
Output value for ON (0...255)	<b>0...255</b>
A concrete 1-byte output value can be assigned to each 1-bit input status. This parameter defines the output value for ON telegrams. This parameter is only visible when the input should react to ON telegrams.	
Output value for OFF (0...255)	<b>0...255</b>
A concrete 1-byte output value can be assigned to each 1-bit input status. This parameter defines the output value for OFF telegrams. This parameter is only visible when the input should react to OFF telegrams.	
Transmission criteria	<b>always transmit when the input is updated</b> transmit only if the output changes transmit cyclically
<p>The transmission behaviour of the output can be configured here.</p> <p><b>Always transmit when the input is updated:</b> The output transmits the current object value to the KNX with every telegram that is received at the input.</p> <p><b>Transmit only if the output changes:</b> The output only transmits the current object value if the object value has changed compared to the last transmission process. During the first telegram to an input after bus voltage return or after an ETS programming operation, the output always transmits to an input.</p> <p><b>Transmit cyclically:</b> With this setting, the output transmits the current object value to the KNX cyclically. After bus voltage return or after an ETS programming operation, the cyclical transmission is only started once the first telegram has been received at the input. The output also transmits as soon as a new telegram is received at the input. At the same time, the cycle time for cyclical transmission is restarted!</p>	

Transmission delay for sending the hours result (0...99)	0...99
<p>An optional delay before result transmission (telegram at output) can be configured.</p> <p>With the setting "always transmit when the input is updated": Telegrams at the output are only transmitted after the trigger when the delay has elapsed. The delay time is restarted by each telegram at the input.</p> <p>With the setting "only transmit if the output changes": Telegrams are only sent when the object value changes at the output if the delay has expired. If the logic function is reprocessed by a new telegram at the input within the delay time and the object value changes again, then the delay restarts. If the object value of the output does not change due to new input telegrams, the delay does not restart.</p> <p>This parameter defines the hours of the delay time.</p>	
Minutes (0...59)	0...59
<p>This parameter defines the minutes of the delay time.</p>	
Seconds (0...59)	0...59
<p>This parameter defines the seconds of the delay time.</p> <p>The parameters for the transmission delay are only visible for "Transmission criteria" = "Always transmit when the input is updated" and "Only transmit when the output changes".</p>	
Cycle time hours (0...99)	0...99
<p>During cyclical transmission of the output, this parameter defines the cycle time.</p> <p>Setting the cycle time hours.</p>	
Minutes (0...59)	0...5...59
<p>This parameter defines the minutes of the cycle time.</p>	
Seconds (0...59)	0...59
<p>This parameter defines the seconds of the cycle time.</p> <p>The parameters for the cycle time are only visible if "transmission criteria" = "transmit cyclically".</p>	

### 11.3.2 Converter object list

Object no.	Function	Name	Type	DPT	Flag
970, 974, 978, 982, 986, 990, 994, 998	Converter Input	Logic... - Input	1-bit	1,002	C, (R), W, -, A

1-bit object as input of a converter. It is possible to configure whether the converter responds to ON and OFF commands or alternatively processes only ON or only OFF telegrams.

This object is only available if the type of logic function is configured to "converter".

Object no.	Function	Name	Type	DPT	Flag
971, 975, 979, 983, 987, 991, 995, 999	Converter Disabling function	Logic... - Input	1-bit	1,002	C, (R), W, -, A

1-bit object as disabling input of a converter. A disabled converter no longer processes input states and consequently does not convert any new output values (the last value is retained and transmitted cyclically, if necessary).

The telegram polarity can be configured.

This object is only available if the type of logic function is configured to "converter".

Object no.	Function	Name	Type	DPT	Flag
1106, 1107, 1108, 1109, 1110, 1111, 1112, 1113	Converter Output	Logic... - Output	1 bytes	5,001	C, (R), -, T, A

1-byte object as value output of a converter.

This object is only available if the type of logic function is configured to "converter".

### 11.4 Disabling element [Filtering/Time]

The disabling element has a 1-bit input and a 1-bit output as well as a disabling object. Input states (ON/OFF) can be delayed independently of one another and filtered at the output before output. The filter makes it possible to invert the states of the output (e.g. ON -> OFF) or to suppress it completely (e.g. OFF -> ---, OFF is not transmitted). If the filter is not used, the disabling element only works with the time functions if required. Alternatively, it is possible to use only the filter (without delays).

The disabling object is able to deactivate the disabling element.

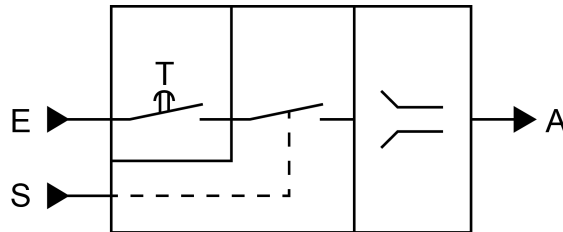

Image 46: Disabling element [Filtering/Time]

The parameter "Time function" defines whether ON or OFF telegrams or both states are evaluated with a delay after reception at the input. If a delay is provided, the delay time can be configured separately for ON and OFF telegrams. A delay is only effective if the delay time is set to greater than "0". Each telegram received at the input re-triggers the receptive delay time.

If no delay is configured, the input telegrams go directly into the filter.

**i** Special feature when using the delays: If no telegram is received at the input, a configured delay time (time > 0) acts like an automatic cyclic trigger of the filter. The most recently received input status is then forwarded to the filter automatically and repeatedly after the delay has elapsed. This then works according to its configuration and forwards the result to the output of the disabling element. Consequently, the output then also transmits telegrams depending on the transmission criteria set. If the cyclical transmission of the output is not desired due to the automatic triggering of the filter, the transmission criterion should be set to "only transmit if the output changes".

If no delay is provided, the filter is only triggered automatically via the received telegrams and thus not automatically.

**i** After bus voltage return or after an ETS programming operation, the delays are triggered automatically.

The filter is set by the parameter "Filter function" according to the following table.

Filter function	Result
ON -> OFF / OFF -> OFF	Input telegrams are forwarded to the output unchanged. Filter deactivated.
ON -> --- / OFF -> OFF	ON telegrams are filtered and not forwarded to the output. OFF telegrams are forwarded to the output unchanged.

Filter function	Result
ON -> ON / OFF -> ---	OFF telegrams are filtered and not forwarded to the output. ON telegrams are forwarded to the output unchanged.
ON -> OFF / OFF -> ON	ON telegrams are converted to OFF telegrams and OFF telegrams are converted to ON telegrams and are forwarded to the output.
ON -> --- / OFF -> ON	ON telegrams are filtered and not forwarded to the output. OFF telegrams are converted to ON telegrams and forwarded to the output.
ON -> OFF / OFF -> ---	OFF telegrams are filtered and not forwarded to the output. ON telegrams are converted to OFF telegrams and forwarded to the output.

The disabling element can be deactivated by the disabling object. A deactivated disabling element no longer forwards any input states to the filter and consequently does not convert any new output values (the last value is retained and transmitted cyclically, if necessary). However, the input states are still evaluated (even with effective delays). At the end of a disabling function, the disabling element is enabled again. The disabling element waits for the next telegram at the input or for the next cycle of the configured delay times.

The telegram polarity of the disabling object can be configured.

The transmission behaviour of the disabling element output can be configured.

### 11.4.1 Disabling element parameters

Logic functions -> Logic function...

Time function	<b>no delay</b> Delay only ON telegrams Delay only OFF telegrams Delay ON and OFF telegrams
---------------	--

This parameter defines whether ON or OFF telegrams or both states are evaluated with a delay after reception at the input. If a delay is provided, the delay time can be configured separately for ON and OFF telegrams. If no delay is configured, the input telegrams go directly into the filter.

Delay for ON telegrams Minutes (0...59)	0...59
--	--------

The delay for ON telegrams is configured here. A delay is only effective if the delay time is set to greater than "0". Each ON telegram received at the input re-triggers the delay time.

Special feature when using the delays: If no telegram is received at the input, a configured delay time (time > 0) acts like an automatic cyclic trigger of the filter. The most recently received input status is then forwarded to the filter automatically and repeatedly after the delay has elapsed. This then works according to its configuration and forwards the result to the output of the disabling element. Consequently, the output then also transmits telegrams depending on the transmission criteria set. If the cyclical transmission of the output is not desired due to the automatic triggering of the filter, the transmission criterion should be set to "only transmit if the output changes".

After bus voltage return or after an ETS programming operation, the delays are triggered automatically.

Setting the ON delay time minutes.

Seconds (0...59)	0...10...59
------------------	-------------

Setting the seconds of the ON delay time.

The parameters for the ON delay are only available if the parameter "Time function" is set to "only delay ON telegrams" or "delay ON and OFF telegrams".



Delay for OFF telegrams Minutes (0...59)	0...59
<p>The delay for OFF telegrams is configured here. A delay is only effective if the delay time is set to greater than "0". Each OFF telegram received at the input re-triggers the delay time.</p> <p>Special feature when using the delays: If no telegram is received at the input, a configured delay time (time &gt; 0) acts like an automatic cyclic trigger of the filter. The most recently received input status is then forwarded to the filter automatically and repeatedly after the delay has elapsed. This then works according to its configuration and forwards the result to the output of the disabling element. Consequently, the output then also transmits telegrams depending on the transmission criteria set. If the cyclical transmission of the output is not desired due to the automatic triggering of the filter, the transmission criterion should be set to "only transmit if the output changes".</p> <p>After bus voltage return or after an ETS programming operation, the delays are triggered automatically.</p> <p>Setting the OFF delay time minutes.</p>	
Seconds (0...59)	0...10...59
<p>Setting the OFF delay time seconds.</p> <p>The parameters for the OFF delay are only available if the parameter "Time function" is set to "only delay OFF telegrams" or "delay ON and OFF telegrams".</p>	
Polarity of the disabling object	<p><b>0 = enabled / 1 = disabled</b></p> <p>0 =disabled/ 1 = enabled</p>
<p>This parameter defines the polarity of the disabling object.</p>	

Filter function	ON -> OFF / OFF -> OFF ON -> --- / OFF -> OFF ON -> ON / OFF -> --- ON -> OFF / OFF -> ON ON -> --- / OFF -> ON ON -> OFF / OFF -> ---
-----------------	---

This parameter defines the function of the filter.

ON -> ON / OFF -> OFF: Input telegrams are forwarded to the output unchanged. Filter deactivated.

ON -> --- / OFF -> OFF: ON telegrams are filtered and not forwarded to the output. OFF telegrams are forwarded to the output unchanged.

ON -> ON / OFF -> ---: OFF telegrams are filtered and not forwarded to the output. ON telegrams are forwarded to the output unchanged.

ON -> OFF / OFF -> ON: ON telegrams are converted to OFF telegrams and OFF telegrams are converted to ON telegrams and forwarded to the output.

ON -> --- / OFF -> ON: ON telegrams are filtered and not forwarded to the output. OFF telegrams are converted to ON telegrams and forwarded to the output.

ON -> OFF / OFF -> ---: OFF telegrams are filtered and not forwarded to the output. ON telegrams are converted to OFF telegrams and forwarded to the output.

Transmission criteria	always transmit when the input is updated transmit only if the output changes transmit cyclically
-----------------------	---

The transmission behaviour of the output can be configured here.

Always transmit when the input is updated: The output transmits the current object value to the KNX with every telegram that is received at the input. In addition, transmission at the output is repeated if no telegram was received at the input when the delay times were used and the configured time has expired.

Transmit only if the output changes: The output only transmits the current object value if the object value has changed compared to the last transmission process. After bus voltage return or an ETS programming operation, the output always transmits.

Transmit cyclically: With this setting, the output transmits the current object value to the KNX cyclically. After bus voltage return or after an ETS programming operation, the cyclical transmission is only started once the first telegram has been received at the input. If the ON / OFF delay is used, after bus voltage return or after an ETS programming, operation cyclical transmission starts automatically once the delay time has expired. The output also transmits as soon as a new telegram is received at the input. At the same time, the cycle time for cyclical transmission is restarted!

Cycle time hours (0...99)	0...99
---------------------------	--------

During cyclical transmission of the output, this parameter defines the cycle time. Setting the cycle time hours.

Minutes (0...59)	0...5...59
This parameter defines the minutes of the cycle time.	
Seconds (0...59)	0...59
This parameter defines the seconds of the cycle time. The parameters for the cycle time are only visible if "transmission criteria" = "transmit cyclically".	

### 11.4.2 Disabling element object list

Object no.	Function	Name	Type	DPT	Flag
970, 974, 978, 982, 986, 990, 994, 998	Disabling element Input	Logic... - Input	1-bit	1,002	C, (R), W, -, A
<p>1-bit object as input of a disabling element.</p> <p>This object is only available if the type of logic function is configured to "disabling element".</p>					

Object no.	Function	Name	Type	DPT	Flag
971, 975, 979, 983, 987, 991, 995, 999	Disabling element Disabling function	Logic... - Input	1-bit	1,002	C, (R), W, -, A
<p>1-bit object as disabling input of a disabling element. A disabled disabling element no longer forwards any input states to the filter and consequently does not convert any new output values (the last value is retained and transmitted cyclically, if necessary).</p> <p>The telegram polarity can be configured.</p> <p>This object is only available if the type of logic function is configured to "disabling element".</p>					

Object no.	Function	Name	Type	DPT	Flag
1058, 1060, 1062, 1064, 1066, 1068, 1070, 1072	Disabling element Output	Logic... - Output	1-bit	1,002	C, (R), -, T, A
<p>1-bit object as output of a disabling element.</p> <p>This object is only available if the type of logic function is configured to "disabling element".</p>					

## 11.5 Comparator

The comparator works with an input whose data format can be parameterised, and with a 1-bit output to output the result of the comparison operation. The comparator compares the value received at the input with a configured reference value and evaluates whether the reference is correct (result = true) or not (result = false) according to the specified reference function.

The reference function and the reference value are configured in the ETS.

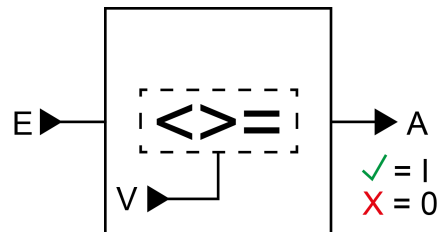

Image 47: Comparator

The parameter "data format" defines the size and format of input object according to the following table. The output object is preset to 1-bit (DPT 1.002) and outputs the result of the comparison operation (ON = true / OFF = false). The reference value that can be set in the ETS adapts to the input data format.

Data format	KNX DPT
4-bit dimming	3,007
1-byte operating mode switchover	20,102
1-byte scene extension	18,001
1-byte value 0...255	5,010
1-byte brightness value 0...100%	5,001
2-byte value 0...65535	7,001
2-byte value -32768...32767	8,001
2-byte floating-point number	9.0xx
4-byte value -2147483648...2147483647	13,001

The following table shows the possible reference functions (I = input value, R = reference value).

Reference function	Function
equal (I = R)	The comparator output is "ON" (true) if the input is equal to the reference value. Otherwise the output is "OFF" (false).
unequal (I ≠ R)	The comparator output is "ON" (true) if the input is unequal to the reference value. If the input value is equal to the reference value, the output is "OFF" (false).
greater than (I > R)	The comparator output is "ON" (true) if the input is greater than the reference value. If the input value is less than or equal to the reference value, the output switches "OFF" (false).

Reference function	Function
greater than or equal to ( $I \geq R$ )	The comparator output is "ON" (true) if the input is greater than the reference value or equal to the reference value. If the input value is less than the reference value, the output switches "OFF" (false).
less than ( $I < R$ )	The comparator output is "ON" (true) if the input is less than the reference value. If the input value is greater than or equal to the reference value, the output switches "OFF" (false).
less than or equal to ( $I \leq R$ )	The comparator output is "ON" (true) if the input is less than the reference value or equal to the reference value. If the input value is greater than the reference value, the output switches "OFF" (false).
Range testing less than ( $R1 < I < R2$ )	There are two reference values. The comparator output is "ON" (true) if the input is greater than the first reference value or less than the second reference value. If the input value is less than the first reference value or equal to the first reference value or greater than the second reference value or equal to the second reference value, the output switches "OFF" (wrong).
Range testing less than or equal to ( $R1 \leq I \leq R2$ )	There are two reference values. The comparator output is "ON" (true) if the input is greater than or equal to the first reference value and less than or equal to the second reference value. If the input value is less than the first reference value or greater than the second reference value, the output switches "OFF" (false).

The transmission behaviour of the comparator output can be configured.

### 11.5.1 Comparator parameters

Logic functions -> Logic function...

Data format	4-bit dimming (DPT 3.007) 1-byte operating mode switchover (DPT 20.102) 1-byte scene extension (DPT 18.001) <b>1-byte value 0...255 (DPT 5.010)</b> 1-byte brightness value 0...100% (DPT 5.001) 2-byte value 0...65535 (DPT 7.001) 2-byte value -32768...32767 (DPT 8.001) 2-byte floating-point number (DPT 9.0xx) 4-byte value -2147483648...2147483647 (DPT 13.001)
<p>This parameter defines the size and format of input object. The output object is preset to 1-bit (DPT 1.002) and outputs the result of the comparison operation (ON = true / OFF = false).</p>	



Reference function	<p><b>equal (I = R)</b>                  unequal (I ≠ R)                  greater than (I &gt; R)                  greater than or equal to (I ≥ R)                  less than (I &lt; R)                  less than or equal to (I ≤ R)                  Range testing less than (R1 &lt; I &lt; R2)                  Range testing less than or equal to (R1 ≤ I ≤ R2)</p>
<p>The comparator compares the value received (I) at the input with a configured reference value (R) and evaluates whether the comparison is correct (result = true) or not (result = false) according to the specified reference function here.</p> <p><b>equal (I = R):</b> The comparator output is "ON" (true) if the input is equal to the reference value. Otherwise the output is "OFF" (false).</p> <p><b>unequal (I ≠ R):</b> The comparator output is "ON" (true) if the input is unequal to the reference value. If the input value is equal to the reference value, the output is "OFF" (false).</p> <p><b>greater than (I &gt; R):</b> The comparator output is "ON" (true) if the input is greater than the reference value. If the input value is less than or equal to the reference value, the output switches "OFF" (false).</p> <p><b>greater than or equal to (I ≥ R):</b> The comparator output is "ON" (true) if the input is greater than the reference value or equal to the reference value. If the input value is less than the reference value, the output switches "OFF" (false).</p> <p><b>less than (I &lt; R):</b> The comparator output is "ON" (true) if the input is less than the reference value. If the input value is greater than or equal to the reference value, the output switches "OFF" (false).</p> <p><b>less than or equal to (I ≤ R):</b> The comparator output is "ON" (true) if the input is less than the reference value or equal to the reference value. If the input value is greater than the reference value, the output switches "OFF" (false).</p> <p><b>Range testing less than (R1 &lt; I &lt; R2):</b> There are two reference values. The comparator output is "ON" (true) if the input is greater than the first reference value or less than the second reference value. If the input value is less than the first reference value or equal to the first reference value or greater than the second reference value or equal to the second reference value, the output switches "OFF" (wrong).</p> <p><b>Range testing less than or equal to (R1 ≤ I ≤ R2):</b> There are two reference values. The comparator output is "ON" (true) if the input is greater than or equal to the first reference value and less than or equal to the second reference value. If the input value is less than the first reference value or greater than the second reference value, the output switches "OFF" (false).</p>	

Reference value (V)	<p><b>dimming darker, stop (0)</b></p> <p>dimming darker, 100% (1)</p> <p>dimming darker, 50% (2)</p> <p>dimming darker, 25% (3)</p> <p>dimming darker, 12.5% (4)</p> <p>dimming darker, 6% (5)</p> <p>dimming darker, 3% (6)</p> <p>dimming darker, 1.5% (7)</p> <p>increase brightness, stop (8)</p> <p>increase brightness, 100% (9)</p> <p>increase brightness, 50% (10)</p> <p>increase brightness, 25% (11)</p> <p>increase brightness, 12.5% (12)</p> <p>increase brightness, 6% (13)</p> <p>increase brightness, 3% (14)</p> <p>increase brightness, 1.5% (15)</p>
---------------------	--

This parameter specifies the internal reference value (R) for the reference function.  
 This parameter is only available if the "data format" is set to "4-bit dimming (DPT 3.007)".

Reference value (V)	<p><b>automatic (0)</b></p> <p>Comfort mode (1)</p> <p>Standby mode (2)</p> <p>Night mode (3)</p> <p>Frost/heat protection (4)</p>
---------------------	--

This parameter specifies the internal reference value (R) for the reference function.  
 This parameter is only available if the "data format" is set to "1 byte operating mode switchover (DPT 20.102)".

Reference value (V)	<p><b>Recall scene 1 (0)</b></p> <p>Recall scene 2 (1)</p> <p>...</p> <p>Recall scene 64 (63)</p> <p>Save scene 1 (128)</p> <p>Save scene 2 (129)</p> <p>...</p> <p>Save scene 64 (191)</p>
---------------------	---

This parameter specifies the internal reference value (R) for the reference function.  
 This parameter is only available if the "data format" is set to "1 byte scene extension (DPT 18.001)".

Reference value (V) (0...255)	0...255
<p>This parameter specifies the internal reference value (R) for the reference function.                  This parameter is only available if the "data format" is set to "1 byte value -0...255 (DPT 5.010)".</p>	
Reference value (V) (0...100%)	0...100
<p>This parameter specifies the internal reference value (R) for the reference function.                  This parameter is only available if the "data format" is set to "1 byte brightness value 0...100% (DPT 5.001)".</p>	
Reference value (V) (0...65535)	0...65535
<p>This parameter specifies the internal reference value (R) for the reference function.                  This parameter is only available if the "data format" is set to "2 byte value 0...65535 (DPT 7.001)".</p>	
Reference value (V) (-32768...32767)	-32768...0...32767
<p>This parameter specifies the internal reference value (R) for the reference function.                  This parameter is only available if the "data format" is set to "2 byte value -32768...32767 (DPT 8.001)".</p>	
Reference value (V) (-671088...670760)	-671088...0...670760
<p>This parameter specifies the internal reference value (R) for the reference function.                  This parameter is only available if the "data format" is set to "2 byte floating point value (DPT 9.0xx)".</p>	
Reference value (V) (-2147483648...2147483647)	-2147483648...0...2147483647
<p>This parameter specifies the internal reference value (R) for the reference function.                  This parameter is only available if the "data format" is set to "4 byte value -2147483648...2147483647 (DPT 13.001)".</p>	

- i** Two reference values (R1 & R2) can be configured if the range testing is configured as "reference function". In this case, the setting options are identical.

Transmission criteria	<p><b>always transmit when the input is updated</b>                  transmit only if the output changes                  transmit cyclically</p>
<p>The transmission behaviour of the output can be configured here.</p> <p><b>Always transmit when the input is updated:</b> The output transmits the current object value to the KNX with every telegram that is received at the input.</p> <p><b>Transmit only if the output changes:</b> The output only transmits the current object value if the object value has changed compared to the last transmission process. During the first telegram to an input after bus voltage return or after an ETS programming operation, the output always transmits to an input.</p> <p><b>Transmit cyclically:</b> With this setting, the output transmits the current object value to the KNX cyclically. After bus voltage return or after an ETS programming operation, the cyclical transmission is only started once the first telegram has been received at the input. The output also transmits as soon as a new telegram is received at the input. At the same time, the cycle time for cyclical transmission is restarted!</p>	
Transmission delay for sending the hours result (0...99)	0...99
<p>An optional delay before result transmission (telegram at output) can be configured.</p> <p>With the setting "always transmit when the input is updated": Telegrams at the output are only transmitted after the trigger when the delay has elapsed. The delay time is restarted by each telegram at the input.</p> <p>With the setting "only transmit if the output changes": Telegrams are only sent when the object value changes at the output if the delay has expired. If the logic function is reprocessed by a new telegram at the input within the delay time and the object value changes again, then the delay restarts. If the object value of the output does not change due to new input telegrams, the delay does not restart.</p> <p>This parameter defines the hours of the delay time.</p>	
Minutes (0...59)	0...59
<p>This parameter defines the minutes of the delay time.</p>	
Seconds (0...59)	0...59
<p>This parameter defines the seconds of the delay time.</p> <p>The parameters for the transmission delay are only visible for "Transmission criteria" = "Always transmit when the input is updated" and "Only transmit when the output changes".</p>	
Cycle time hours (0...99)	0...99
<p>During cyclical transmission of the output, this parameter defines the cycle time.</p> <p>Setting the cycle time hours.</p>	
Minutes (0...59)	0...5...59
<p>This parameter defines the minutes of the cycle time.</p>	

Seconds (0...59)	0...59
<p>This parameter defines the seconds of the cycle time.</p> <p>The parameters for the cycle time are only visible if "transmission criteria" = "transmit cyclically".</p>	

### 11.5.2 Comparator object list

Object no.	Function	Name	Type	DPT	Flag
1002, 1003, 1004, 1005, 1006, 1007, 1008, 1009	Comparator Input	Logic... - Input	4-bit	3,007	C, (R), W, -, A

4-bit object as input of a comparator.  
This object is only available if the type of logic function is configured to "comparator" and the data format is configured to "4-bit dimming (DPT 3.007)".

Object no.	Function	Name	Type	DPT	Flag
1018, 1019, 1020, 1021, 1022, 1023, 1024, 1025	Comparator Input	Logic... - Input	1 bytes	20,102	C, (R), W, -, A

1-byte object as input of a comparator.  
This object is only available if the type of logic function is configured to "comparator" and the data format is configured to "1 byte operating mode switchover (DPT 20.102)".

Object no.	Function	Name	Type	DPT	Flag
1018, 1019, 1020, 1021, 1022, 1023, 1024, 1025	Comparator Input	Logic... - Input	1 bytes	18,001	C, (R), W, -, A

1-byte object as input of a comparator.  
This object is only available if the type of logic function is configured to "comparator" and the data format is configured to "1 byte scene extension (DPT 18.001)".

Object no.	Function	Name	Type	DPT	Flag
1018, 1019, 1020, 1021, 1022, 1023, 1024, 1025	Comparator Input	Logic... - Input	1 bytes	5,010	C, (R), W, -, A

1-byte object as input of a comparator.  
This object is only available if the type of logic function is configured to "comparator" and the data format is configured to "1-byte value 0...255 (DPT 5.010)".

Object no.	Function	Name	Type	DPT	Flag
1018, 1019, 1020, 1021, 1022, 1023, 1024, 1025	Comparator Input	Logic... - Input	1 bytes	5,001	C, (R), W, -, A

1-byte object as input of a comparator.

This object is only available if the type of logic function is configured to "comparator" and the data format is configured to "1-byte brightness value 0...100% (DPT 5.001)".

Object no.	Function	Name	Type	DPT	Flag
1034, 1035, 1036, 1037, 1038, 1039, 1040, 1041	Comparator Input	Logic... - Input	2 bytes	7,001	C, (R), W, -, A

2-byte object as input of a comparator.

This object is only available if the type of logic function is configured to "comparator" and the data format is configured to "2-byte value 0...65535 (DPT 7.001)".

Object no.	Function	Name	Type	DPT	Flag
1034, 1035, 1036, 1037, 1038, 1039, 1040, 1041	Comparator Input	Logic... - Input	2 bytes	8,001	C, (R), W, -, A

2-byte object as input of a comparator.

This object is only available if the type of logic function is configured to "comparator" and the data format is configured to "2-byte value -32768...32767 (DPT 8.001)".

Object no.	Function	Name	Type	DPT	Flag
1034, 1035, 1036, 1037, 1038, 1039, 1040, 1041	Comparator Input	Logic... - Input	2 bytes	9,xxx	C, (R), W, -, A

2-byte object as input of a comparator.

This object is only available if the type of logic function is configured to "comparator" and the data format is configured to "2-byte floating point value (DPT 9.0xx)".

Object no.	Function	Name	Type	DPT	Flag
1050, 1051, 1052, 1053, 1054, 1055, 1056, 1057	Comparator Input	Logic... - Input	4 bytes	13,001	C, (R), W, -, A

4-byte object as input of a comparator.

This object is only available if the type of logic function is configured to "comparator" and the data format is configured to "4-byte value -2147483648...2147483647 (DPT 13.001)".



Object no.	Function	Name	Type	DPT	Flag
1058, 1060, 1062, 1064, 1066, 1068, 1070, 1072	Comparator Output	Logic... - Output	1-bit	1,002	C, (R), -, T, A
1-bit object as output of a comparator. The output object is preset to 1-bit (DPT 1.002) and outputs the result of the comparison operation (ON = true / OFF = false). This object is only available if the type of logic function is configured to "comparator".					

## 11.6 Limit value switch

The limit value switch works with an input whose data format can be configured, and with a 1-bit output to output the result of the threshold evaluation. The limit value switch compares the value received at the input with two configurable hysteresis threshold values. Once the upper threshold value (H2) is reached or exceeded, the output can transmit a switching telegram (e.g. ON = true). If the value falls below the lower threshold value (H1), the output can transmit another switching telegram (e.g. OFF = false).

The switching telegrams can always be configured in the ETS when the threshold values are exceeded and undershot.

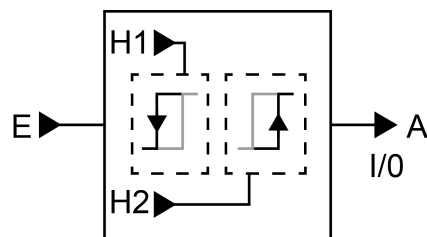

Image 48: Limit value switch

The two threshold values define a hysteresis. The hysteresis prevents frequent switching back and forth of the output, provided that the input value changes continuously in small intervals. Only when the change in value at the input exceeds the hysteresis as a whole, does the output switch the status.

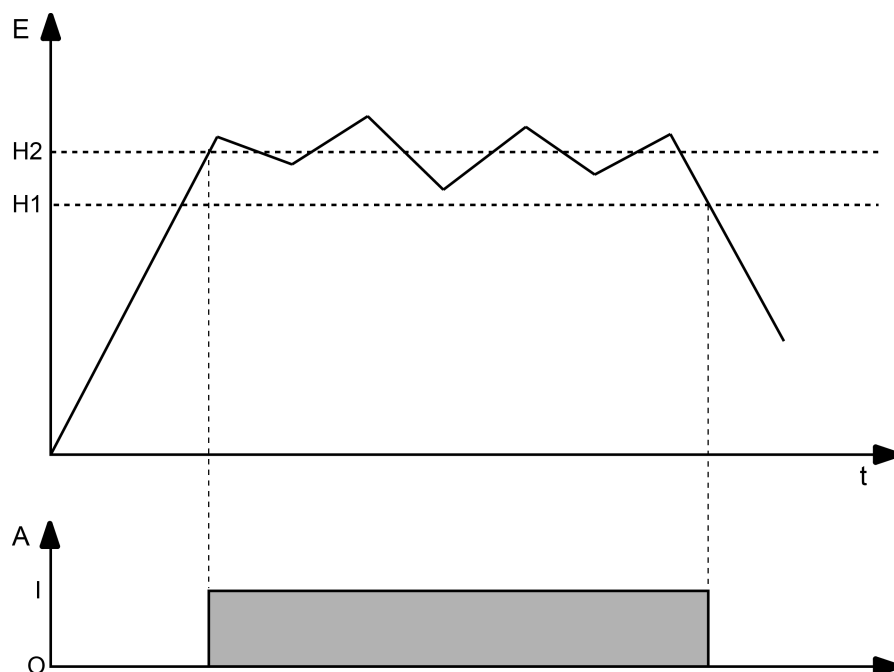

Image 49: Example of a hysteresis evaluation by upper and lower threshold value

- i** The two threshold values can be freely configured in the ETS. Make sure that the upper threshold value is greater than the lower one!

- i** After bus voltage return or after an ETS programming operation, the output always transmits a telegram when the first value has been received at the input. The telegram depends on whether the value reaches or exceeds the upper threshold (H2) or not. If the value is less than the upper threshold, a telegram is transmitted in accordance with "Telegram upon not reaching the lower threshold". Otherwise the output transmits the "telegram on exceeding the upper threshold value".

The parameter "data format" defines the size and format of input object according to the following table. The output object is preset to 1-bit (DPT 1.002) and outputs the result of the threshold evaluation (ON = true / OFF = false). The threshold values that can be set in the ETS adapt to the input data format.

Data format	KNX DPT
4-bit dimming	3,007
1-byte operating mode switchover	20,102
1-byte scene extension	18,001
1-byte value 0...255	5,010
1-byte brightness value 0...100%	5,001
2-byte value 0...65535	7,001
2-byte value -32768...32767	8,001
2-byte floating-point number	9.0xx
4-byte value -2147483648...2147483647	13,001

The transmission behaviour of the limit value switch can be configured.

### 11.6.1 Limit value switch parameters

Logic functions -> Logic function...

<p>Data format</p>	<p>4-bit dimming (DPT 3.007)                      1-byte operating mode switchover (DPT 20.102)                      1-byte scene extension (DPT 18.001)  <b>1-byte value 0...255 (DPT 5.010)</b>                      1-byte brightness value 0...100% (DPT 5.001)                      2-byte value 0...65535 (DPT 7.001)                      2-byte value -32768...32767 (DPT 8.001)                      2-byte floating-point number (DPT 9.0xx)                      4-byte value -2147483648...2147483647 (DPT 13.001)</p>
<p>This parameter defines the size and format of input object. The output object is preset to 1-bit (DPT 1.002) and outputs the result of the threshold evaluation (ON = true / OFF = false).</p>	
<p>Lower threshold value (H1)</p>	<p><b>dimming darker, stop (0)</b>                      dimming darker, 100% (1)                      dimming darker, 50% (2)                      dimming darker, 25% (3)                      dimming darker, 12.5% (4)                      dimming darker, 6% (5)                      dimming darker, 3% (6)                      dimming darker, 1.5% (7)                      increase brightness, stop (8)                      increase brightness, 100% (9)                      increase brightness, 50% (10)                      increase brightness, 25% (11)                      increase brightness, 12.5% (12)                      increase brightness, 6% (13)                      increase brightness, 3% (14)                      increase brightness, 1.5% (15)</p>
<p>This parameter defines the lower threshold value (H1) of the limit value switch.                      This parameter is only available if the "data format" is set to "4-bit dimming (DPT 3.007)".</p>	

Lower threshold value (H1)	<b>automatic (0)</b> Comfort mode (1) Standby mode (2) Night mode (3) Frost/heat protection (4)
----------------------------	---

This parameter defines the lower threshold value (H1) of the limit value switch.  
 This parameter is only available if the "data format" is set to "1 byte operating mode switchover (DPT 20.102)".

Lower threshold value (H1)	<b>Recall scene 1 (0)</b> Recall scene 2 (1) ... Recall scene 64 (63) Save scene 1 (128) Save scene 2 (129) ... Save scene 64 (191)
----------------------------	--

This parameter defines the lower threshold value (H1) of the limit value switch.  
 This parameter is only available if the "data format" is set to "1 byte scene extension (DPT 18.001)".

Lower threshold value (H1) (0...255)	<b>0...255</b>
---	----------------

This parameter defines the lower threshold value (H1) of the limit value switch.  
 This parameter is only available if the "data format" is set to "1 byte value -0...255 (DPT 5.010)".

Lower threshold value (H1) (0...100%)	<b>0...100</b>
--	----------------

This parameter defines the lower threshold value (H1) of the limit value switch.  
 This parameter is only available if the "data format" is set to "1 byte brightness value 0...100% (DPT 5.001)".

Lower threshold value (H1) (0...65535)	<b>0...65535</b>
---	------------------

This parameter defines the lower threshold value (H1) of the limit value switch.  
 This parameter is only available if the "data format" is set to "2 byte value 0...65535 (DPT 7.001)".

Lower threshold value (H1) (-32768...32767)	-32768...0...32767
This parameter defines the lower threshold value (H1) of the limit value switch. This parameter is only available if the "data format" is set to "2 byte value -32768...32767 (DPT 8.001)".	
Lower threshold value (H1) (-671088...670760)	-671088...0...670760
This parameter defines the lower threshold value (H1) of the limit value switch. This parameter is only available if the "data format" is set to "2 byte floating point value (DPT 9.0xx)".	
Lower threshold value (H1) (-2147483648...2147483647)	-2147483648...0...2147483647
This parameter defines the lower threshold value (H1) of the limit value switch. This parameter is only available if the "data format" is set to "4 byte value -2147483648...2147483647 (DPT 13.001)".	
Upper threshold value (H2)	<ul style="list-style-type: none"> <li><b>dimming darker, stop (0)</b></li> <li>dimming darker, 100% (1)</li> <li>dimming darker, 50% (2)</li> <li>dimming darker, 25% (3)</li> <li>dimming darker, 12.5% (4)</li> <li>dimming darker, 6% (5)</li> <li>dimming darker, 3% (6)</li> <li>dimming darker, 1.5% (7)</li> <li>increase brightness, stop (8)</li> <li>increase brightness, 100% (9)</li> <li>increase brightness, 50% (10)</li> <li>increase brightness, 25% (11)</li> <li>increase brightness, 12.5% (12)</li> <li>increase brightness, 6% (13)</li> <li>increase brightness, 3% (14)</li> <li>increase brightness, 1.5% (15)</li> </ul>
This parameter defines the upper threshold value (H2) of the limit value switch. This parameter is only available if the "data format" is set to "4-bit dimming (DPT 3.007)".	

Upper threshold value (H2)	<b>automatic (0)</b> Comfort mode (1) Standby mode (2) Night mode (3) Frost/heat protection (4)
This parameter defines the upper threshold value (H2) of the limit value switch. This parameter is only available if the "data format" is set to "1 byte operating mode switchover (DPT 20.102)".	
Upper threshold value (H2)	<b>Recall scene 1 (0)</b> Recall scene 2 (1) ... Recall scene 64 (63) Save scene 1 (128) Save scene 2 (129) ... Save scene 64 (191)
This parameter defines the upper threshold value (H2) of the limit value switch. This parameter is only available if the "data format" is set to "1 byte scene extension (DPT 18.001)".	
Upper threshold value (H2) (0...255)	<b>0...255</b>
This parameter defines the upper threshold value (H2) of the limit value switch. This parameter is only available if the "data format" is set to "1 byte value -0...255 (DPT 5.010)".	
Upper threshold value (H2) (0...100%)	<b>0...100</b>
This parameter defines the upper threshold value (H2) of the limit value switch. This parameter is only available if the "data format" is set to "1 byte brightness value 0...100% (DPT 5.001)".	
Upper threshold value (H2) (0...65535)	<b>0...65535</b>
This parameter defines the upper threshold value (H2) of the limit value switch. This parameter is only available if the "data format" is set to "2 byte value 0...65535 (DPT 7.001)".	



Upper threshold value (H2) (-32768...32767)	-32768...0...32767
<p>This parameter defines the upper threshold value (H2) of the limit value switch.</p> <p>This parameter is only available if the "data format" is set to "2 byte value -32768...32767 (DPT 8.001)".</p>	
Upper threshold value (H2) (-671088...670760)	-671088...0...670760
<p>This parameter defines the upper threshold value (H2) of the limit value switch.</p> <p>This parameter is only available if the "data format" is set to "2 byte floating point value (DPT 9.0xx)".</p>	
Upper threshold value (H2) (-2147483648...2147483647)	-2147483648...0...2147483647
<p>This parameter defines the upper threshold value (H2) of the limit value switch.</p> <p>This parameter is only available if the "data format" is set to "4 byte value -2147483648...2147483647 (DPT 13.001)".</p>	
Telegram on reaching or exceeding the upper threshold value	<b>ON telegram</b> OFF telegram
<p>The telegram of the output upon reaching or exceeding the upper threshold can be configured here.</p>	
Telegram on falling below the lower threshold value	<b>ON telegram</b> <b>OFF telegram</b>
<p>The telegram of the output upon not reaching the lower threshold can be configured here.</p>	
Transmission criteria	<b>always transmit when the input is updated</b> transmit only if the output changes transmit cyclically
<p>The transmission behaviour of the output can be configured here.</p> <p>Always transmit when the input is updated: The output transmits the current object value to the KNX with every telegram that is received at the input.</p> <p>Transmit only if the output changes: The output only transmits the current object value if the object value has changed compared to the last transmission process. During the first telegram to an input after bus voltage return or after an ETS programming operation, the output always transmits to an input.</p> <p>Transmit cyclically: With this setting, the output transmits the current object value to the KNX cyclically. After bus voltage return or after an ETS programming operation, the cyclical transmission is only started once the first telegram has been received at the input. The output also transmits as soon as a new telegram is received at the input. At the same time, the cycle time for cyclical transmission is restarted!</p>	

Transmission delay for sending the hours result (0...99)	0...99
<p>An optional delay before result transmission (telegram at output) can be configured.</p> <p>With the setting "always transmit when the input is updated": Telegrams at the output are only transmitted after the trigger when the delay has elapsed. The delay time is restarted by each telegram at the input.</p> <p>With the setting "only transmit if the output changes": Telegrams are only sent when the object value changes at the output if the delay has expired. If the logic function is reprocessed by a new telegram at the input within the delay time and the object value changes again, then the delay restarts. If the object value of the output does not change due to new input telegrams, the delay does not restart.</p> <p>This parameter defines the hours of the delay time.</p>	
Minutes (0...59)	0...59
<p>This parameter defines the minutes of the delay time.</p>	
Seconds (0...59)	0...59
<p>This parameter defines the seconds of the delay time.</p> <p>The parameters for the transmission delay are only visible for "Transmission criteria" = "Always transmit when the input is updated" and "Only transmit when the output changes".</p>	
Cycle time hours (0...99)	0...99
<p>During cyclical transmission of the output, this parameter defines the cycle time.</p> <p>Setting the cycle time hours.</p>	
Minutes (0...59)	0...5...59
<p>This parameter defines the minutes of the cycle time.</p>	
Seconds (0...59)	0...59
<p>This parameter defines the seconds of the cycle time.</p> <p>The parameters for the cycle time are only visible if "transmission criteria" = "transmit cyclically".</p>	

## 11.6.2 Limit value switch object list

Object no.	Function	Name	Type	DPT	Flag
1002, 1003, 1004, 1005, 1006, 1007, 1008, 1009	Limit value switch Input	Logic... - Input	4-bit	3,007	C, (R), W, -, A
<p>4-bit object as input of a limit value switch.</p> <p>This object is only available if the type of logic function is configured to "limit value switch" and the data format is configured to "4-bit dimming (DPT 3.007)".</p>					

Object no.	Function	Name	Type	DPT	Flag
1018, 1019, 1020, 1021, 1022, 1023, 1024, 1025	Limit value switch Input	Logic... - Input	1 bytes	20,102	C, (R), W, -, A
<p>1-byte object as input of a limit value switch.</p> <p>This object is only available if the type of logic function is configured to "limit value switch" and the data format is configured to "1 byte operating mode switchover (DPT 20.102)".</p>					

Object no.	Function	Name	Type	DPT	Flag
1018, 1019, 1020, 1021, 1022, 1023, 1024, 1025	Limit value switch Input	Logic... - Input	1 bytes	18,001	C, (R), W, -, A
<p>1-byte object as input of a limit value switch.</p> <p>This object is only available if the type of logic function is configured to "limit value switch" and the data format is configured to "1 byte scene extension (DPT 18.001)".</p>					

Object no.	Function	Name	Type	DPT	Flag
1018, 1019, 1020, 1021, 1022, 1023, 1024, 1025	Limit value switch Input	Logic... - Input	1 bytes	5,010	C, (R), W, -, A
<p>1-byte object as input of a limit value switch.</p> <p>This object is only available if the type of logic function is configured to "limit value switch" and the data format is configured to "1-byte value 0...255 (DPT 5.010)".</p>					

Object no.	Function	Name	Type	DPT	Flag
1018, 1019, 1020, 1021, 1022, 1023, 1024, 1025	Limit value switch Input	Logic... - Input	1 bytes	5,001	C, (R), W, -, A

1-byte object as input of a limit value switch.

This object is only available if the type of logic function is configured to "limit value switch" and the data format is configured to "1-byte brightness value 0...100% (DPT 5.001)".

Object no.	Function	Name	Type	DPT	Flag
1034, 1035, 1036, 1037, 1038, 1039, 1040, 1041	Limit value switch Input	Logic... - Input	2 bytes	7,001	C, (R), W, -, A

2-byte object as input of a limit value switch.

This object is only available if the type of logic function is configured to "limit value switch" and the data format is configured to "2-byte value 0...65535 (DPT 7.001)".

Object no.	Function	Name	Type	DPT	Flag
1034, 1035, 1036, 1037, 1038, 1039, 1040, 1041	Limit value switch Input	Logic... - Input	2 bytes	8,001	C, (R), W, -, A

2-byte object as input of a limit value switch.

This object is only available if the type of logic function is configured to "limit value switch" and the data format is configured to "2-byte value -32768...32767 (DPT 8.001)".

Object no.	Function	Name	Type	DPT	Flag
1034, 1035, 1036, 1037, 1038, 1039, 1040, 1041	Limit value switch Input	Logic... - Input	2 bytes	9,xxx	C, (R), W, -, A

2-byte object as input of a limit value switch.

This object is only available if the type of logic function is configured to "limit value switch" and the data format is configured to "2-byte floating point value (DPT 9.0xx)".

Object no.	Function	Name	Type	DPT	Flag
1050, 1051, 1052, 1053, 1054, 1055, 1056, 1057	Limit value switch Input	Logic... - Input	4 bytes	13,001	C, (R), W, -, A

4-byte object as input of a limit value switch.

This object is only available if the type of logic function is configured to "limit value switch" and the data format is configured to "4-byte value -2147483648...2147483647 (DPT 13.001)".

Object no.	Function	Name	Type	DPT	Flag
1058, 1060, 1062, 1064, 1066, 1068, 1070, 1072	Limit value switch Output	Logic... - Output	1-bit	1,002	C, (R), -, T, A

1-bit object as output of a limit value switch. The output object is preset to 1-bit (DPT 1.002) and outputs the result of the threshold evaluation (ON = true / OFF = false).

This object is only available if the type of logic function is configured to "limit value switch".

## 12 As-delivered state

In the as-delivered state, the actuator is passive, i.e. no telegrams are transmitted to the bus. The outputs can, however, be activated by manual operation on the device if the bus voltage and the valve voltage supply are on. In manual operation, no feedback telegrams are sent to the bus. Other functions of the actuator, such as the room temperature controllers, are deactivated.

The device can be programmed and put into operation via the ETS. The physical address is preset to 15.15.255

Furthermore, the device has been configured at the factory with the following characteristics (all valve outputs)...

- Valve direction of action: deenergised closed
- Pulse width modulation on "Open valve": 50%
- Cycle time: 20 minutes
- Behaviour in case of bus voltage failure: All the valve outputs switch OFF.
- Behaviour after bus voltage return: All valve outputs switch OFF.

**Gira**  
**Giersiepen GmbH & Co. KG**  
Elektro-Installations-  
Systeme

Industriegebiet Mermbach  
Dahlienstraße  
42477 Radevormwald

Postfach 12 20  
42461 Radevormwald

Deutschland

Tel +49(0)21 95 - 602-0  
Fax +49(0)21 95 - 602-191

[www.gira.de](http://www.gira.de)  
[info@gira.de](mailto:info@gira.de)